

Moulded photoplastic probes for near-field optical applications

B. J. KIM*, J. W. FLAMMA†, E. S. TEN HAVE†, M. F. GARCIA-PARAJO†, N. F. VAN HULST† & J. BRUGGER*

*Strategic Research Orientation NanoLink and †Applied Optics Group, MESA⁺ Research Institute, University of Twente, PO Box 217, 7500 AE Enschede, The Netherlands

Key words. Dry lift-off, near-field optical probes, microfabrication, self-assembled monolayer, SU-8.

Summary

The inexpensive fabrication of high-quality probes for near-field optical applications is still unsolved although several methods for integrated fabrication have been proposed in the past. A further drawback is the intensity loss of the transmitted light in the ‘cut-off’ region near the aperture in tapered optical fibres typically used as near-field probes. As a remedy for these limitations we suggest here a new wafer-scale semibatch microfabrication process for transparent photoplastic probes. The process starts with the fabrication of a pyramidal mould in silicon by using the anisotropic etchant potassium hydroxide. This results in an inverted pyramid limited by $\langle 111 \rangle$ silicon crystal planes having an angle of $\sim 54^\circ$. The surface including the mould is covered by a ~ 1.5 nm thick organic monolayer of dodecyltrichlorosilane (DTS) and a 100-nm thick evaporated aluminium film. Two layers of photoplastic material are then spin-coated (thereby conformal filling the mould) and structured by lithography to form a cup for the optical fibre microassembly. The photoplastic probes are finally lifted off mechanically from the mould with the aluminium coating. Focused ion beam milling has been used to subsequently form apertures with diameters in the order of 80 nm. The advantage of our method is that the light to the aperture area can be directly coupled into the probe by using existing fibre-based NSOM set-ups, without the need for far-field alignment, which is typically necessary for cantilevered probes. We have evidence that the aluminium layer is considerably smoother compared to the ‘grainy’ layers typically evaporated on free-standing probes. The optical throughput efficiency was measured to be about 10^{-4} . This new NSOM probe was directly bonded to a tuning fork sensor for the shear force control and the topography of a polymer sample was successfully obtained.

Correspondence: Jürgen Brugger. Tel: + 31 53 489 5652; fax: + 31 53 4892575; e-mail: J.Brugger@el.utwente.nl

Introduction

The development of multifunctional scanning probe microscopy and optical microscopy continues to be a topic of research and growing interest, since each new type of probe enables the microscopic measurement of new physical, chemical and biological properties.

Near-field scanning optical microscopy (NSOM) overcomes the diffraction limit of resolution and has hence become a widely used technique for the optical investigation of materials in the sub-wavelength range (e.g. Pohl *et al.*, 1984; Hess, 1994). However, further applications of the technique, especially in the field of biology and surface chemistry, are hampered mainly due to the unavailability of inexpensive high-quality probes, in contrast to the success story of the atomic force microscope (AFM) during the past decade. Even though several methods for integrated fabrication have been proposed, the inexpensive fabrication of high-quality probes for near-field optical applications is still unsolved.

The most widely used NSOM probe is a tapered optical fibre obtained by CO₂-laser heating and subsequent pulling, which is shadow coated with aluminium thus creating an aperture. The desirable properties of such aperture probes are high brightness (obtained by large cone angles), a well-defined aperture for good polarization characteristics, no light leaking through pinholes in the metal coating, and a high optical damage threshold.

The drawbacks of these fibre probes arise from the insufficient reproducibility of the fabrication process of both the tapered fibre as well as the aperture. The aperture-forming evaporation process on a free-standing sharpened optical fibre is difficult to control and commonly results in deficiencies such as an undetermined shape and size of the opening as well as light transmitting pin holes on the side walls of the fibre. Additionally, it creates voluminous metal clusters protruding irregularly from the aperture rim. The

grains (10 nm up to 50 nm) at the end of the probe increase the distance between the aperture and the sample, leading to a reduction of both resolution and intensity.

An alternative approach to the manufacture of NSOM probes is wet chemical etching (Hoffmann *et al.*, 1995; Stockle *et al.*, 1999). As these tapers have a larger cone angle than pulled tapers, the optical throughput can be considerably higher for the same aperture size. Chemically etched probes have higher throughputs, but they still suffer from roughness, asymmetry of the tip apex, and problems caused by the aluminium coating. Furthermore, the end face of these tips is not flat but rounded, which effectively decreases the resolution.

Recently, microfabricated tips have been presented in the literature (Abraham *et al.*, 1998; Oesterschulze *et al.*, 1998; Drews *et al.*, 1999), although they are not yet commercially available. Improved aperture definition, polarization behaviour and imaging capabilities of fibre NSOM aperture probes have been achieved by using the focused ion beam technique, which is capable of polishing the end of the probe on a nanometre scale (Veerman *et al.*, 1998).

We propose here a new attempt to solve the manufacturing problem by using a semibatch wafer-scale microfabrication process for sharp pyramidal and bright photoplastic probes.

Probe fabrication

The fabrication steps are adapted from a recently proposed technique to manufacture low-cost AFM probes (Genolet *et al.*, 1999). The process consists of the following steps:

- wafer-scale etching of probe moulds in silicon;
- anti-stiction coating with a self-assembled monolayer (SAM);
- spin-on and lithographical structuring of SU-8 cups;
- direct micro-assembly/bonding with optical fibre;
- aperture formation by focused ion beam (FIB).

The schematic figure and scanning electron microscope (SEM) image of the fabricated probe is shown in Fig. 1. The process chart is shown in Fig. 2.

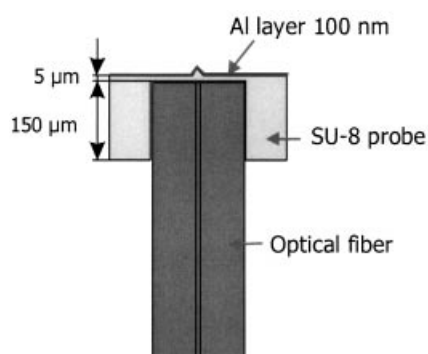

Fig. 1. Schematic (left) and scanning electron micrograph (right) of a microfabricated and assembled photoplastic NSOM probe.

Photoplastic material (SU-8)

The probes are fabricated from a transparent photoplastic material (SU-8) which allows simple batch fabrication based on spin coating and subsequent near-ultraviolet exposure and development steps. SU-8, an epoxy-based, negative tone, near-ultraviolet (UV) photoresist is used increasingly in the growing field of microelectro-mechanical-systems (MEMS) as photoresist as well as structural material. It consists of the epoxy-based EPON SU-8 resin photosensitized with a triaryl sulphonium salt. For MEMS applications, the main interest feature of the resist includes the possibility to define high aspect ratio structures at low-cost, without the need for an expensive X-ray source (as, for example, required in LIGA). The main interest for 'optical MEMS' applications is that SU-8 is transparent with a refractive index of ~ 1.8 as shown by Arscott *et al.* (1999). The material covers surface contours conformal down to the nanometer range. These combined advantages are used here to define a sharp pyramidal and transparent probe dedicated for near-field optical applications. The process starts with the fabrication of moulds in a (100) orientated silicon wafer by using the anisotropic etchant potassium hydroxide (KOH). This process is self-limiting and results in inverted sharp pyramids limited by four $\langle 111 \rangle$ silicon crystal planes. The cone angle is in the order of $\sim 54^\circ$. Subsequently, the radius of the pyramidal tip apex in the mould is sharpened by a low temperature wet thermal oxidation process (Akamine & Quate, 1992).

SAM coating as antistiction layer

To be able to remove the transparent probe from the mould together with the aluminium film we make use of a self-assembled monolayer (SAM) as anti-adhesion coating. The layer will assist in the removal of microfabricated photoplastic NSOM tips from the surface without wet chemical sacrificial layer etching. The role of the molecular nanocarpet in this configuration is to reduce the adhesion between Al and SiO_2 , yet to provide enough stability to

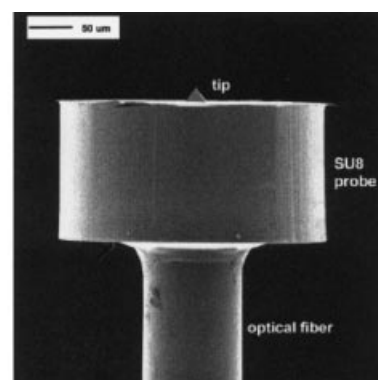

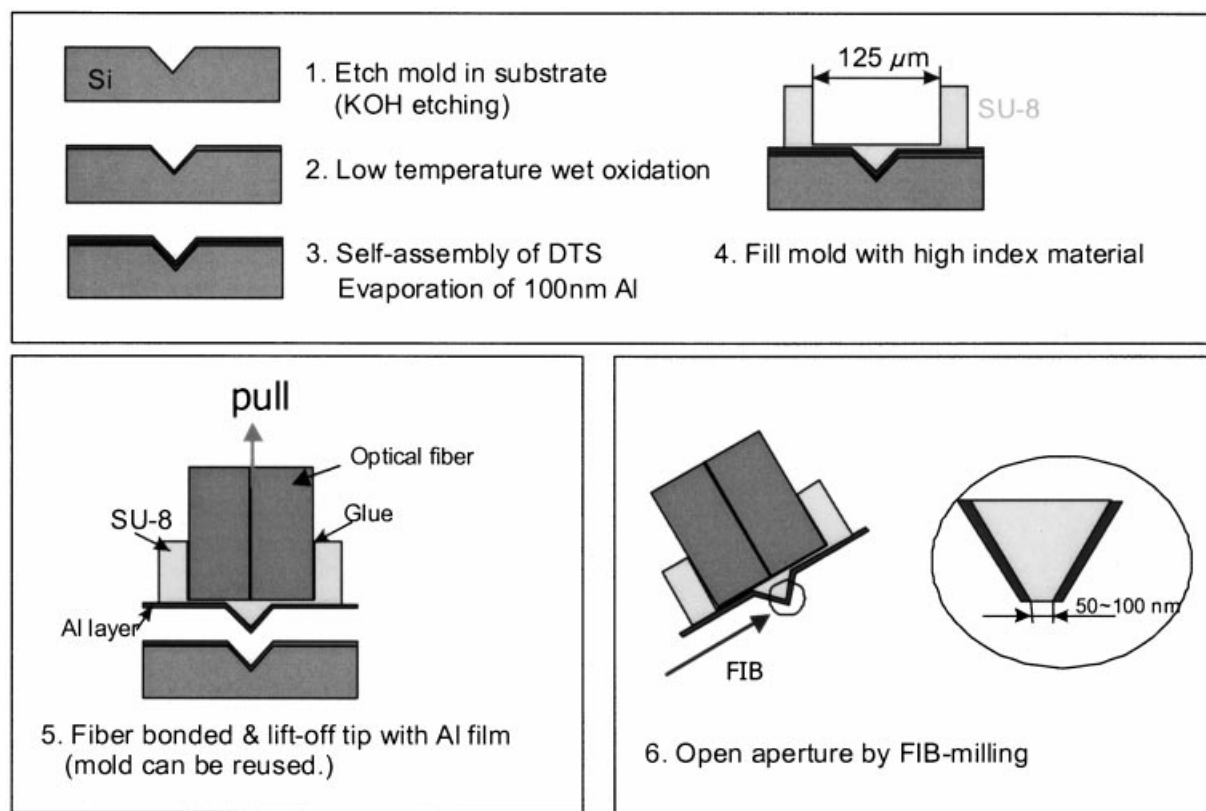

Fig. 2. Microfabrication process chart for SU-8 NSOM probe.

support all subsequent micromachining process steps, such as multiple resist spinning, thermal steps, development and etching (Kim *et al.*, 2000).

Organosilicon derivatives R_nSiX_{3-n} , where X is chloride or alkoxy, are known to form a SAM on hydroxylated surfaces (Sagiv, 1980). In our case, a ~ 1.5 -nm thick SAM is formed on an oxidized silicon surface by immersing it into a solution of typically 5–10 mM dodecyltrichlorosilane (DTS) in dry toluene for about 2 h. Thereby a network of molecules is formed connecting them to the surface and to each other by covalent bonds (Fig. 3). The SAM covers surface contours to the nanometre scale very conformal. This enables the precise replication and de-moulding of functionalized microfabricated NSOM tips.

Tip fabrication and fibre bonding

A 100-nm thick layer of Al is evaporated directly onto the SAM as a light-absorbing opaque layer. Photoplastic SU-8 is then conformal spin-coated and structured by simple lithography to form cup-like containers designed to incorporate the standard optical fibre, which is aligned and bonded to the probe using optical adhesive (NOA73). The glue is cured by ultraviolet light and provides good optical index matching. The probes are then removed from the mould

together with the metal layer. A unique asset of this technique is that the Al film has a very smooth surface with less than 0.8-nm mean surface roughness as measured by atomic force microscopy (AFM). We have evidence that the aluminium layer is considerably smoother compared to the 'grainy' layers typically evaporated on free-standing probes as shown in Fig. 4. Therefore we expect to be able to reduce their thickness, which is advantageous for the probe

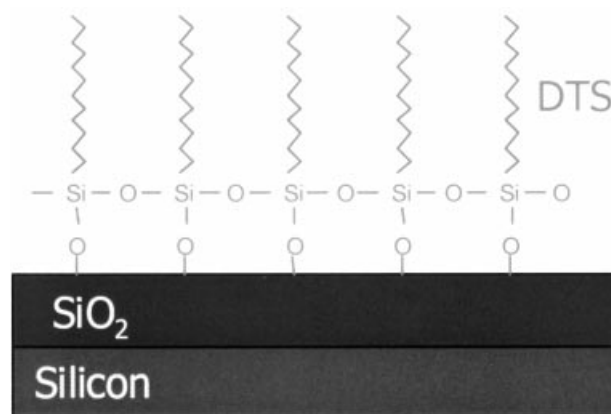
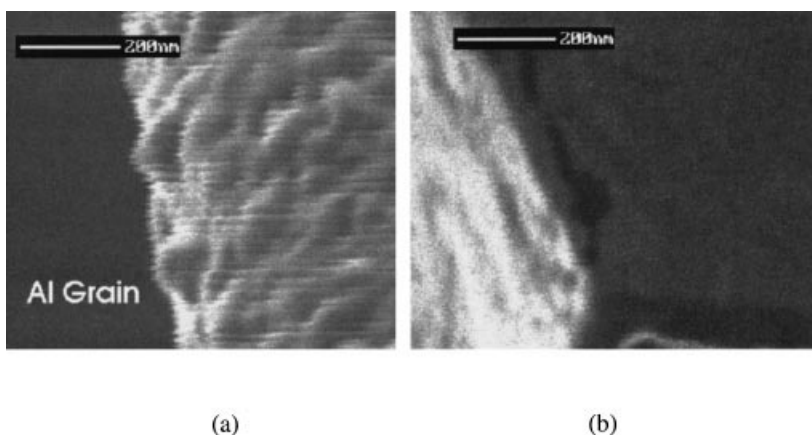

Fig. 3. Schematic representation of a self-assembled monolayer (SAM) of dodecyltrichlorosilane (DTS) on a hydroxylated surface.

Fig. 4. Scanning electron micrograph showing the Al surfaces of (a) rough post-evaporated film on free-standing optical fibre, and (b) smooth Al layer resulting from lift-off process using the new surface release technique assisted by self-assembled monolayer.



geometry. The assembling, bonding and releasing process was carried out manually; however, an automatic assembly system could be envisioned to enable mass fabrication. These novel NSOM probes are fully compatible with conventional fibre-based NSOM set-ups. In addition, the end of the optical fibre could be etched to reduce its diameter, which would enable a smaller form factor of the overall probe dimension.

Aperture formation

Finally, apertures in the aluminium film are formed by focused ion beam (FIB) milling with an ion beam of 4 pA at 30 kV. Gallium ions focused to a beam of 10 nm are scanned at 90° with the tip axis, thereby removing a very thin slice of material from the tip end. Figure 5 shows a typical image of an SU-8 probe with a square aperture of about 90 × 90 nm² aperture.

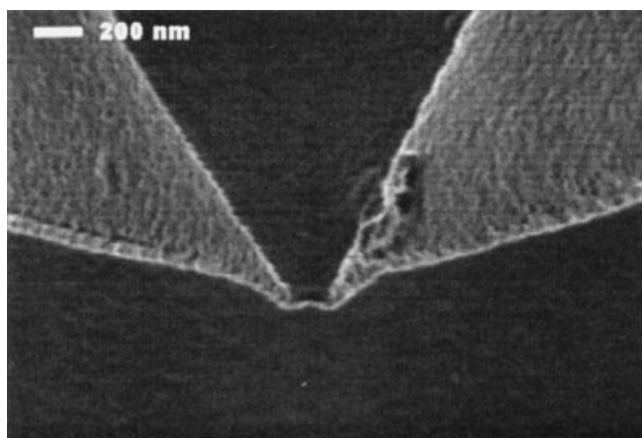

Fig. 5. Focused ion beam images showing FIB-chopped NSOM probes with aperture size of 80 × 80 nm².

Experimental results

Shear force control of SU-8 NSOM probes

Shear force feedback based on tuning fork sensors has been used to control the distance between tip and sample (e.g. Ruiter *et al.*, 1997). A newly microfabricated SU-8 NSOM probe is directly attached to a piezoelectric quartz tuning fork as shown in Fig. 6. The tuning fork is mechanically driven with < 1 nm dither amplitude using an external piezo actuator. The resonant frequency of the entire probe, tuning fork, fibre and attached SU-8 tip is ~33.7 kHz with a quality factor of $Q = 150$. Height feedback is performed by keeping the phase difference between the driving excitation and the tuning fork signal constant. The phase set point was chosen close to the out-of contact value. The tip-sample distance is typically 10 nm with a noise level below 1 nm.

The probe was scanned over a flat polymer sample (spin-coated 10 nm-thick polymethylmethacrylate on glass) containing some dispersed protrusions. Two typical topographic images are shown in Fig. 7. The scan area is 3.2 μm × 3.2 μm², with 300 × 300 pixels per image and an integration time of 3 ms pixel⁻¹. These images compare to topographic images taken by conventional fibre probes, thus we are confident that our new SU-8 probes are well suited for this mode of operation.

Far-field measurements of probe throughput efficiency are typically ~10⁻⁴ for an aperture of 80 nm. This confirms that our pyramidal probes are indeed very bright and are suitable for NSOM applications.

Conclusions and outlook

A new wafer-scale process has been presented capable of fabricating a large amount of probes suitable for NSOM application. The process is based on a photoplastic material structured by lithography and a low-cost moulding technique. An innovative dry-release process using an organic

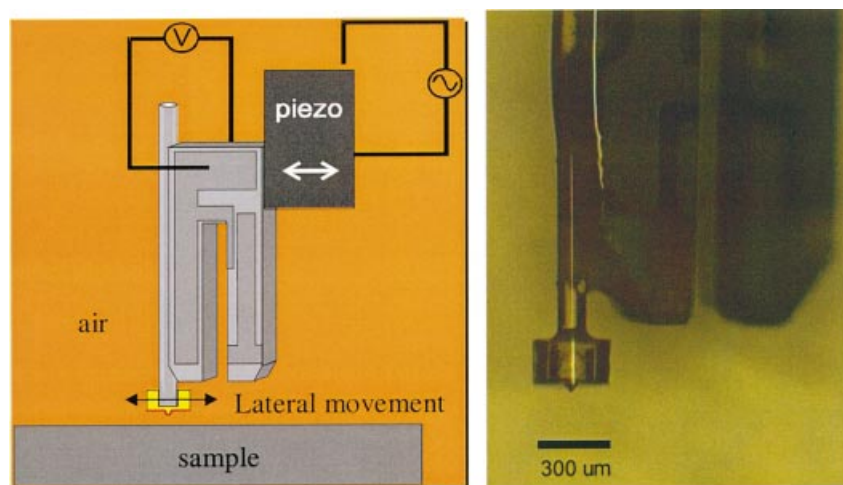

Fig. 6. Schematic view of shear force control and tuning fork sensor bonded to the SU-8 NSOM probe.

monolayer has enabled us to integrally fabricate the transparent probe with a very smooth Al coating of less than 0.8 nm rms surface roughness. Throughput efficiency of an 80-nm aperture appears to be 10^{-4} . We have obtained topographic images using a tuning fork based shear force distance control set-up.

The major advantages of our approach are:

- simple, low-cost semibatch fabrication process suitable for mass production;
- high optical efficiency due to the large cone angle;
- smooth aluminium layer integrally made on the probe (no post-deposition);
- direct coupling to optical fibre.

In the near future we plan to improve further the monolayer chemistry and metal film coating technique to prevent the formation of pinholes near the aperture,

currently apparent after the mechanical removal. Furthermore, an integrated aperture formation process prior to the metal coating would make this moulding technique a true batch process for low-cost probes, which would further advance near-field optical techniques in the fields of microscopy, data storage and lithography.

Acknowledgements

The authors would like to thank M. Liebau, J. Huskens and D.N. Reinhoudt from the Supramolecular Chemistry and Technology Group at MESA⁺ for fruitful discussion about self-assembled monolayer treatment, A. M. Otter and F. B. Segerink for FIB-milling, and all MESA⁺ cleanroom staff for technical support of microfabrication. Gyuman Kim is acknowledged for assistance with the manuscript. This

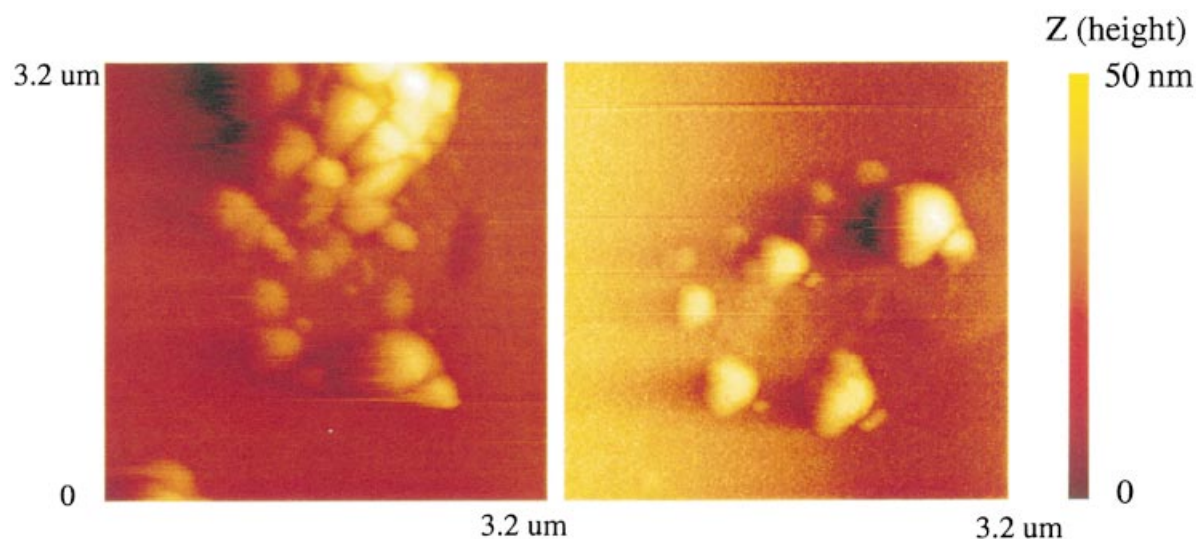

Fig. 7. Topographic images of spin-coated 10 nm PMMA on glass taken with the new photoplastic SU-8 probe.

project is financially supported by the MESA⁺ NanoLink Strategic Research Orientation.

References

- Abraham, M., Ehrfeld, W., Lacher, M., Mayr, K., Noell, W., Guthner, P. & Barenz, J. (1998) Micromachined aperture probe tip for multifunctional scanning probe microscopy. *Ultramicroscopy*, **71**, 93–98.
- Akamine, S. & Quate, C.F. (1992) Low-temperature thermal-oxidation sharpening of microcast tips. *J. Vacuum Sci. Technol. B*, **10**, 2307–2310.
- Arcsott, S., Garat, F., Mounaix, P., Duvillaret, L., Coutaz, J.L. & Lippens, D. (1999) Terahertz time-domain spectroscopy of films fabricated from SU-8. *Electron. Lett.* **35**, 243–244.
- Drews, D., Ehrfeld, W., Lacher, M., Mayr, K., Noell, W., Schmitt, S. & Abraham, M. (1999) Nanostructured probes for scanning near-field optical microscopy. *Nanotechnology*, **10**, 61–64.
- Genolet, G., Brugger, J., Despont, M., Drechsler, U., Vettiger, P., de Rooij, N.F. & Anselmetti, D. (1999) Soft, entirely photoplastic probes for scanning force microscopy. *Rev. Scientific Instruments*, **70**, 2398–2401.
- Hess, H.F., Betzig, E., Harris, T.D., Pfeiffer, L.N. & West, K.W. (1994) Near-field spectroscopy of the quantum constituents of a luminescent system. *Science*, **264**, 1740–1745.
- Hoffmann, P., Dutoit, B. & Salathe, R.-P. (1995) Comparison of mechanically drawn and protection layer chemically etched optical fiber tips. *Ultramicroscopy*, **61**, 165–170.
- Kim, B., Liebau, M., Huskens, J., Reinhoudt, D.N. & Brugger, J. (2000) 'SAMS meet MEMS' – a monolayer assisted surface microfabrication and release technique. *Microelectronic Engineering*, in press.
- Oesterschulze, E., Rudow, O., Mihalcea, C., Scholz, W. & Werner, S. (1998) Cantilever probes for SNOM applications with single and double aperture tips. *Ultramicroscopy*, **71**, 85–92.
- Pohl, D.W., Denk, W. & Lanz, M. (1984) Optical sthethoscopy: image recording with resolution 1/20. *Appl. Phys. Lett.* **4**, 651–653.
- Ruiter, A.G.T., Veerman, J.A., van der Werf, K.O. & van Hulst, N.F. (1997) Dynamic behavior of tuning fork shear force feedback. *Appl. Phys. Lett.* **71**, 28–30.
- Sagiv, J. (1980) Organized monolayers by adsorption. I. Formation and structure of oleophobic mixed monolayers on solid surfaces. *J. Amer. Chem. Soc.* **102**, 92–98.
- Stockle, R., Fokas, C., Deckert, V. & Zenobi, R. (1999) High-quality near-field optical probes by tube etching. *Appl. Phys. Lett.* **75**, 160–162.
- Veerman, J.A., Otter, A.M., Kuipers, L. & van Hulst, N.F. (1998) High definition aperture probes for near-field optical microscopy fabricated by focused ion beam milling. *Appl. Phys. Lett.* **72**, 3115–3117.