

# LESS IMPACT OF POWER FAILURES DUE TO SUBSTATION AUTOMATION

Volker Lohmann

ABB Power Automation Ltd., P.O. Box, CH-5620 Baden, Switzerland,

Otto Preiss

ABB Corporate Research Ltd, P.O. Box, CH-5405 Baden-Daettwil, , Switzerland

Tel. +4156 2052414, Fax +4156 205 4828, Email volker.lohmann@chpau.mail.abb.com

## INTRODUCTION

*The management of power failures is a complex endeavour, which needs a diverse set of preventive and corrective measures in order to attain satisfying results. Substation Automations (SA) systems comprise, among others, an infrastructure of intelligent electronic devices (IED) for protection and control. This paper is an attempt to convey that SA can be used to effectively deal with the problems of power interruptions, in that its devices serve as data sources to assess the actual service conditions of main capital plant items, and in that they enable automated and intelligent power restoration procedures as a measure to reduce the power interruption duration, and to avoid the consequences of loss of power for the consumer's business.*

## INTERRUPTION DURATION DEPENDENCIES

Because managing power interruptions involves the consideration of diverse aspects, affecting different functional divisions of a utility, it is a difficult and complex task. However, the final implementation of the strategies to reduce the interruption impact is composed of measures that fall either into the corrective or the preventive category, where the former refers to all measures taken to repair an already occurred failure, and the latter to all measures taken to decrease the probability of a failure occurrence, or to limit the failure impact should one occur. Since the reduction of interruption duration is identified as a critical, and also quantifiable success factor for distribution utilities, the objective of reducing the interruption time can be viewed as one major goal of a utility maintenance policy, and therefore, the management of power interruptions is, among others, largely dependent on the way a utility defines and implements its maintenance strategy.

Maintenance is commonly defined as the set of actions for ensuring that the station achieves a minimum required performance [1], with the key consideration of a maintenance strategy being the minimization of emergency or breakdown repair actions [2]. Thus, it is convincing that the corrective and the preventive maintenance are vital parts in approaching the problem of power interruptions.

Besides maintenance there are other important means of dealing with interruption problems. One is the foreseen and installed network and station equipment redundancy, which is regarded as a preventive measure, and the other

the well-directed deployment of automated reactions to occurred interruptions, regarded as a corrective measure.

Thus, almost all utilities apply a mixed set of measures, and deploy a mixed set of products and technologies that help to maintain their required level of network and substation performance, which, not at last, does focus on fewer or less painful power interruptions.

The graph in Figure 1 illustrates the above discussion and shows the dependency of reducing the interruption duration on the measures taken, and puts them into relation with their major actions and their dependence on underlying secondary systems and equipment.

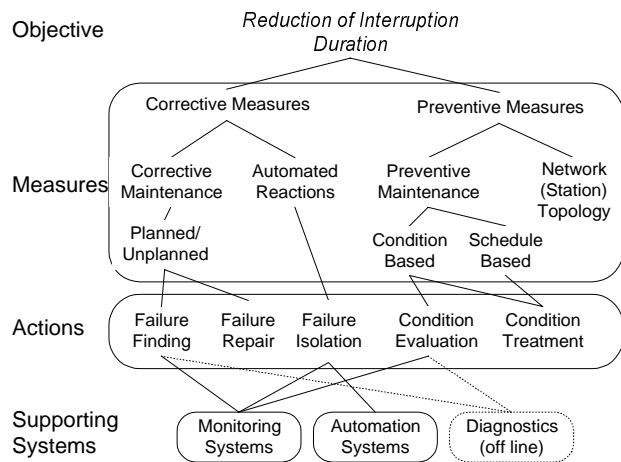

Figure 1: Interruption Duration Dependency Graph

Since the management of power interruptions heavily relies on the deployment of monitoring and automation systems this paper elaborates on the opportunities provided by the latest developments and trends that are seen in these fields and indicates their relevance to the mitigation of the impact of power interruptions.

## AUTOMATION

### Interaction between Protection and Control

With the introduction of numerical relays, with the realisation of modern substation control systems, and with the development of new communications technologies, direct interaction between protection and control leads to adaptive protection schemes, to intelligent load shedding, and to automatic power restoration procedures. The

following examples illustrate how these new functions can be implemented in conjunction with SA concepts as corrective measures to limit the consequences of faults.

### Adaptive Protection

The term “adaptive protection” is related to a protection philosophy which permits and seeks to make adjustments in various protection functions automatically in order to make them more attuned to prevailing power system conditions. This means that the function of a protection relay, measuring local process related quantities could be enhanced by additional information about the network.

### Typical Examples

**Distance Line Protection with Transfer Bus.** The power supply from the public network into an industrial plant is usually highly sensitive against interruptions, as the consequential damages caused may be exorbitant. In order to provide redundancy for the critical line circuit breakers (CB), a transfer bus can be provided and the bus coupler CB can temporarily substitute the faulty line CB (see Figure 2). This means, however, that the bus coupler needs to be equipped not only with busbar current differential protection  $P_C$  but also with distance protection  $P_L$ , which can be adapted to the impedances of the various lines.

The corrective measures, which are automatically initiated in case of faulty line circuit breakers (CB) to restore the power, would be:

1. Isolation of the line CB
2. Initiation of all by-pass connections
3. Activation of the correct distance protection

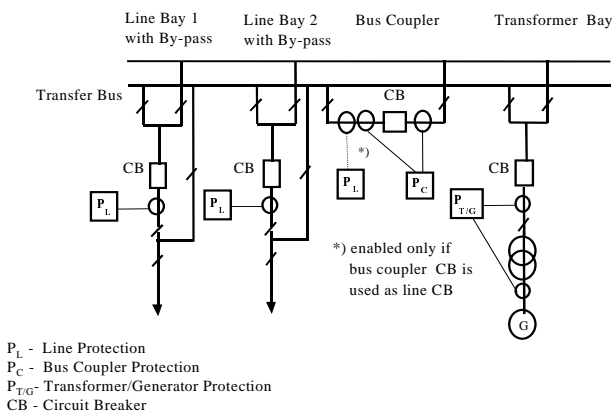

Figure 2: Distance Protection with Transfer Bus

**Compensation of Mutual Impedance.** The next critical areas of failures are the redundant power lines feeding into an industrial plant, which often run in parallel over long distances. The automatic switching of the load from one line to the other as a corrective measure in case of one line being faulty, has to take into account that mutual impedance exists between the parallel lines. This impedance can cause measuring failures, resulting in unnecessary trips initiated by the associated distance relays during earth faults. In order to avoid this, the distance

protection needs to be automatically adapted to the topology of the parallel lines and to the actual service conditions (e.g., parallel, disconnected, earthed or unearthed, both lines connected to different busbars at one side, etc.).

Apart from this, also the power carrying capability of a line may have to be increased by corresponding adaptation of the line protection.

The needed exchange of information between control elements "C" and the protective device "P" is shown in Figure 3.

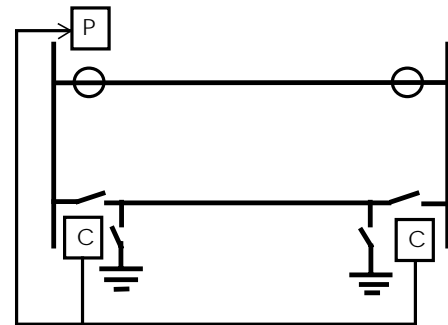

Figure 3: Adaptation of Protection to Line Topology

### Dynamic Load Shedding

Load shedding is a typical corrective measure to assure uninterrupted power supply to vital areas of an industrial plant, if there is an under-frequency condition due to lack of power.

The conventional load shedding approach is static, as it initiates tripping of pre-selected circuit breakers when a certain level of under-frequency is reached, regardless of the actual load conditions. The reason is that the actual load behind each individual circuit breaker is not taken into account.

Microprocessor based load shedding schemes, however, are in the position of considering the actual loads and to dynamically select only those feeders to be opened, which are needed to regain the frequency stability [3].

Load shedding functions can be allocated to a protection or a control device associated with the various bays of an SA system.

The load shedding function block (LSFB) of the dynamic load shedding scheme continuously monitors the load of each feeder (Figure 4). It obtains the actual measured current and voltage values either directly hardwired from dedicated CT's and a busbar VT or via communication links from the CT's and VT's, which are incorporated in the numerical protection/control devices.

The LSFB compares the reference power  $P_{ref}$  with the individual feeder load measurements  $P_1...P_n$ . To each feeder a priority index  $P_r$  is assigned for load shedding. The LSFB selects from the power inputs  $P_1...P_n$  the sum of the power which is larger than  $P_{ref}$  thus minimising the difference between the selected and reference power. If the pre-determined load shedding criteria (LSC) in terms of

under-frequency ( $< f$ ) or frequency change ( $> df/dt$ ) is fulfilled, a predefined percentage  $X\%$  of total load  $P_{tot}$  is shed by opening selected feeders. The selection of the feeders to be opened also takes the predefined priority index  $P_r$  into account.

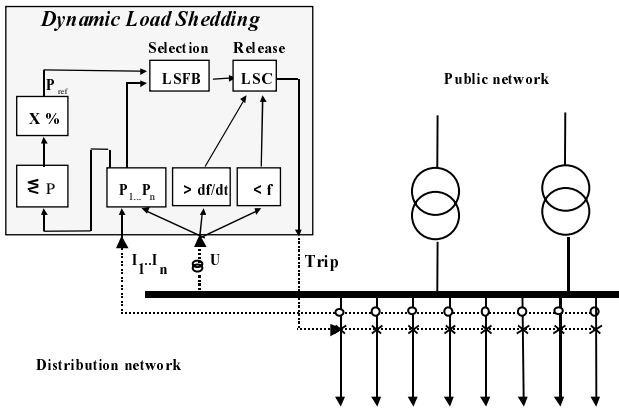

Figure 4: Dynamic Load Shedding for a Distribution Network

If the network frequency continues to drop or remains stable on an under-frequency level, the shed of the next load class is initiated, i.e. shedding of a second predefined percentage  $X\%$  of the total load  $P_{tot}$  (see Figure 5). Otherwise, if the network frequency starts to increase within a definable time delay, the next load class will not be enabled and the load shedding scheme is reset as soon as the network frequency has recovered. If the network frequency has recovered, the integrated network restoration function will be started automatically.

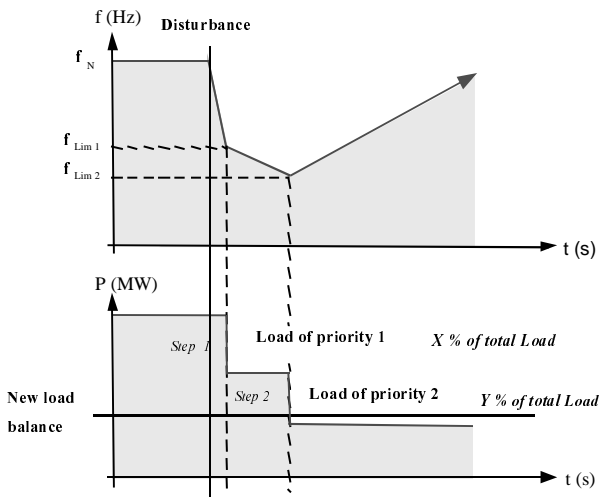

Figure 5: Dynamic Load Shedding

**Benefits.** In contrast to the conventional way of load shedding, stabilisation of the frequency can often be reached in the first shedding step. In addition, only the necessary load is tripped resulting in a minimum impact for the plant supply.

## Network Restoration

Another important feature of the microprocessor based load shedding is selective network restoration, which is comprised of two steps:

1. *Generation increase:* If the load balance is reached the network frequency will get stable on a lower level. To recover the network frequency, activating the generation reserve will increase power generation. The load frequency controller leads the network frequency back to the nominal value.
2. *Network restoration:* The load shedding program has stored the tripped feeders. After the restoration of the frequency the feeders are reconnected one by one. Each reconnected feeder causes a minor load unbalance, which leads to a certain frequency reduction (Figure 6), immediately restored by the load frequency controller. This frequency supervision avoids network collapse during the restoration phase.

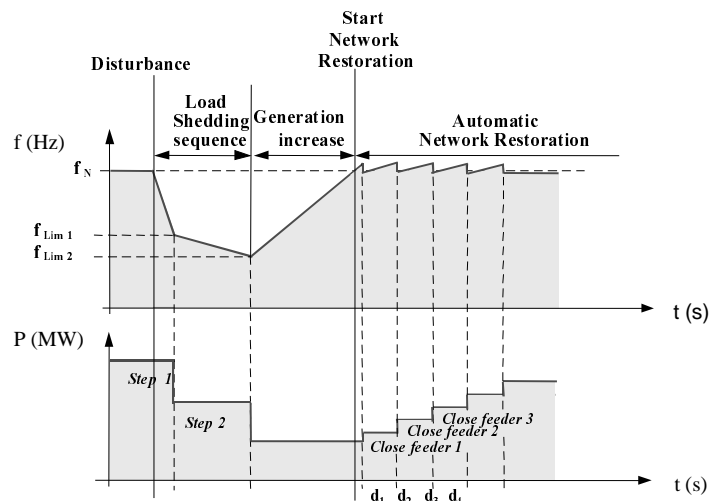

Figure 6: Network Restoration

## Optimisation of Plant Power Supply

A cost-effective application for the optimisation of the power supply for an industry plant is shown in Figure 7. The three busbar systems are geographically located at different areas in an industrial plant. The plant power supply is partly provided by local power generation and partly from the public network. The load shedding functions are integrated in the bay units (control, protection, or combined control/protection units) of the substation automation system.

The load shedding scheme has three objectives:

1. To optimise local and public power supply in order to achieve the minimum energy costs.
2. To provide optimal load shedding in case of lack of power in order to maintain maximum availability.
3. To island the industry plant from the public network in order to limit the impact of a failure on the public lines.

The island procedure is very time critical with regard to frequency stability of the plant power supply and overload of the local generators.

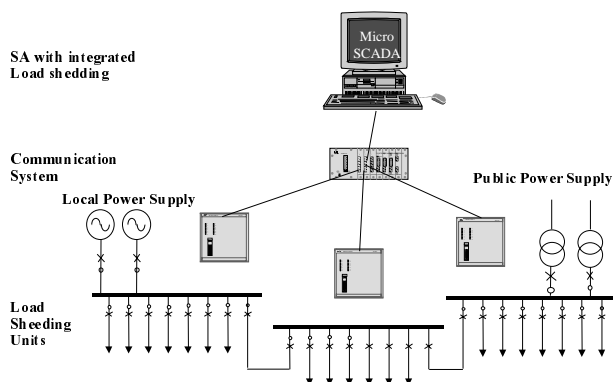

Figure 7: Substation Automation System for Load Shedding

## MONITORING

In context with substation automation, monitoring systems are often defined and understood as functional and even physical subsets of substation automation systems, with mostly the control functionality not being present. This perception has largely been established on the grounds of marketing reasons driven by the substation control system vendors. We believe that this rather narrow focus does no justice to the importance of the monitoring applications, and is backed by the currently growing interest in condition monitoring applications, and the increasingly deployed commercial information technology for standalone monitoring systems. Based on [1] we shall use a more general definition of monitoring :

*A station or network management technique which exploits the regular evaluation of the actual operating condition, in order to minimize the combined costs of power transmission/distribution and maintenance.*

### Why is Monitoring Instrumental to Managing Power Outages?

For once neglecting outages as a result of wrong human operation, there are basically three reasons for power interruptions:

1. The breakdown of a utility asset through normal wear and ageing under working conditions.
2. The breakdown of an asset being effected by an external event (system disturbance), such as a tree falling on an overhead line, that led to a permanent abnormal working condition.
3. A temporary system disturbance where either the external influence disappears ("self-healing"), or a protective system isolates the assets from the electric grid, and by means of network redundancy avoids a power outage at all, or leaves a limited area without power. With respect to the condition of assets,

however, this temporary disturbance most likely caused accelerated wear.

Condition monitoring mainly addresses the wear and ageing caused by normal or temporarily abnormal working conditions. First, in that they support the evaluation of the actual condition of assets, and second, in that they might explicitly support the prediction of the further evolution of a detected problem, and the probability of breakdown. However, many of today's condition monitoring systems leave the assessment of the future to the human's interpretation based on his conclusions drawn from the current status. Whichever, even if a utility decides, e.g., based on risk management considerations, to let a worn out asset in operation until it breaks, the breakdown will be a planned one, and so will the repair action be. Hence, the power interruption will most likely be rather short and the problems posed by the interruption alleviated as good as possible.

Apart from monitoring the condition of primary equipment and thereby attempting to proactively prevent power interruptions, an elaborate post fault analysis supported by monitoring systems is equally important. It has been observed that a large proportion of major blackouts of electric power systems is caused by protective system failures (see [4]). These failures are generally hidden and only exposed during the rare occasion of system disturbances. According to utility opinion derived from a questionnaire (described in [4]) over 60% of these failures are based on wrong protection settings, protection calibration, or protection maintenance. It is therefore important to capture as much details as possible during a system disturbance and have access to as much protection relevant data as possible during the entire analysis. The conceivable subsequent settings refinement phase is a measure to prevent the same interruption from happening again, or, at least, minimise its impact on the power distribution. Since there is no unique terminology for this kind of monitoring systems, we call them *protection monitoring systems*, thus implying that they collect and present all the information important for a protection engineer.

### Trends in Monitoring Systems

Realising that monitoring systems are a vital part of power interruption management, it is interesting to discuss the arising trends in this area.

The above definition of a monitoring system explicitly mentions the combined costs of energy distribution and maintenance. This is an important factor, because, up to now, advanced monitoring systems are hardly deployed at the distribution level due to their high investment costs compared with their expected benefits. We assume that this is about to change for certain reasons:

- Decreasing investment and life-cycle cost of information and data communications technology.
- Availability of basic monitoring functions or data integrated into standard distribution terminals or even the primary equipment.

- Improved condition status estimation techniques and remoting facilities.
- The need for consumer specific power quality and availability, for more efficiently used networks, and for prolonged deployment of utility assets. All driven by ongoing market deregulation.

### **Data Acquisition**

With computing power making its way into the primary equipment, more and more equipment internal data can be made available to the outside at virtually no cost. Interfaces to acquire such internal data were previously not provided for cost reasons. Data that will be accessible includes, but is not restricted to:

- switching counters,
- thermal information,
- quality of isolation media,
- entire timing curves of switching operations,
- switching currents,
- manufacturing data,
- original value of key performance criteria.

This kind of data can be the source of valuable condition information and exploited for building condition monitoring systems for those assets that exhibit the highest failure rates and/or cause unacceptable power interruption impact. Without doubt the transformers and circuit breakers are the prime candidates for these kinds of monitoring systems.

The second trend within the data acquisition falls into the category of intelligent field devices, i.e., secondary equipment like protection terminals. Besides their primary functions, i.e., those justifying the purchase of such a terminal, they host more and more additional functionality, which increase their attractiveness compared with dedicated single function units. Many of these additional functions provide a sound foundation for basic monitoring systems, cost-efficient and perfectly suited for medium and distribution voltage level. Examples of additional functions are:

- Protection or control terminals (bay units, BU in the sequel), but also busbar protection systems which include basic disturbance recorders
- BUs that include sequence of event recorders
- BUs that include rather sophisticated statistical value recording (peak current indicators, number of starts/trips, current at tripping, etc.)
- Power quality analyzers
- General purpose programming capabilities that allow to write and run customer specific applications on the BUs

It goes without saying that all these functions provide data which monitoring systems at station and remote locations can obtain through the serial interfaces of these units.

Some of the more novel data to be acquired by and obtained through monitoring systems are the multimedia data, which allow to provide real audio and video data from a substation and its equipment. They are further discussed in the next section.

### **Data Communications and Presentation**

The most notable trend in monitoring systems is the growing influence of standard information technology. This is dominated and pushed by the world-wide giant efforts put into technologies around the Internet. Some of the most influencing factors are the utilisation of multimedia data, the world-wide web ("Web") as a distributed information source, as well as the utilisation of e-mail technology to distribute all sorts of messages. Apart from this, the growing acceptance of standard browser technology as a means of human machine interaction, and the utilisation of the Internet together with its TCP/IP protocol is more and more accepted by utilities as an existing and viable global communications infrastructure.

The potential benefits of multimedia data lies primarily in the area of monitoring applications for maintenance purpose. Equipment specialists are able to accomplish astonishing results by just listening how a mechanical operation sounds (e.g., a switch operation, or a tap changer operation) or how oil or contacts look like. As far as reduction of power interruption is concerned, it is conceivable that multimedia data delivered from an unmanned station helps to better assess the current problem (e.g., observe that a breaker spring is not charged), and thereby better plan the visit to the station for the emergency repair.

Entirely new applications that build on multimedia data are also arising, like the Internet based supervision of a transmission substation at the new Hong Kong international airport. The security and fire safety related information is provided through the Internet to several interested parties (fire department, transmission grid operators, airport security, etc.). Besides providing real video data with zooming, panning, etc., to authorised parties connected to the Internet, illegal intruders and frequently encountered false fire alarms can automatically be detected.

The consequent deployment of commercial information technology products for the design and implementation of monitoring systems, rather than the reuse of existing proprietary systems, like SCADA platforms, offers cost-effective monitoring solutions at commodity prices. In addition, many of the problems can be avoided which are inherent to the existing legacy systems, such as bandwidth and functional limitations of SCADA protocols, non-standardised application, database, and GUI interfaces.

The less stringent real-time requirements in conjunction with less critical safety requirements for monitoring systems justify such an approach. The benefits of the deployment of these new technologies are, firstly, a wealth of new possibilities, and secondly, a surprisingly high productiveness in creating such systems and applications. The subsequent example shall illustrate the above statements.

### **Example of an Internet Based Monitoring System**

The example shown in figure 8 is a remote monitoring system, which is based on Internet technologies and Java. This system can be applied to the monitoring of

transformers, but also other objects. The framework of GLASS (Global Access for Service and Support) is generic, so that it can be utilised in different application domains.

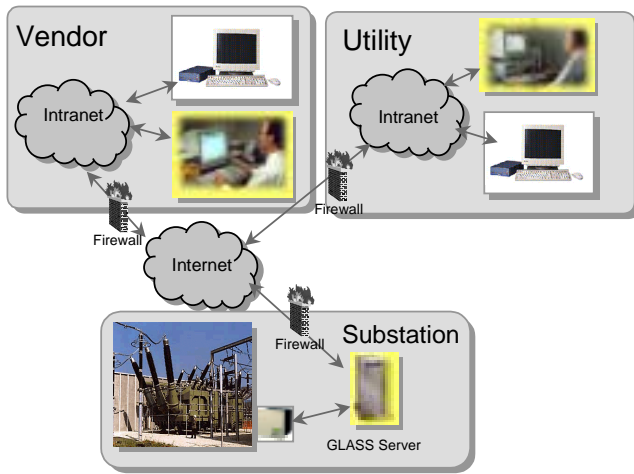

Figure 8: GLASS System Architecture

A medium voltage transformer protection relay contains besides its protection functions also a transformer monitoring function, whose data is collected, processed, and stored on a standard PC. The PC acts as a Web server and can be connected to the public Internet and/or a corporate intranet. Any authorised user may then access the graphically prepared information (HTML pages, applets) through his standard PC Web-browser, i.e., without any further soft- or hardware needed. Hence, a specialist from a vendor located anywhere in the world (even if mobile) can look at the same information in parallel to someone from utility side while they converse over the phone.

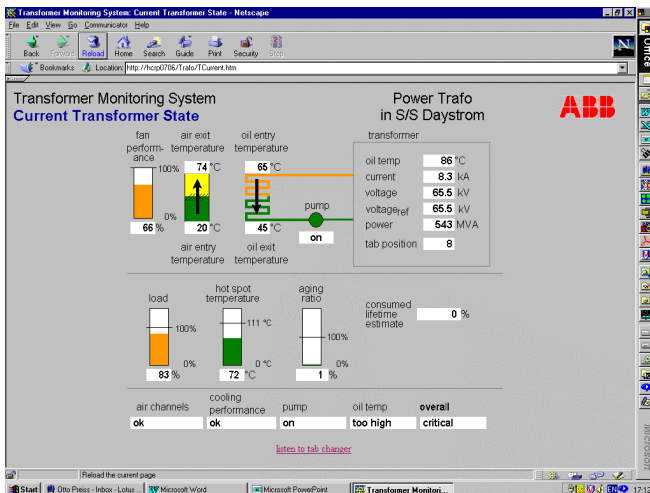

Figure 9: Current Transformer State in a Browser Window

Currently, GLASS provides the following functionality:

- Presentation of the prevailing operating conditions (current, voltage, tap position, etc.)
- Supervision and automatic control of transformer cooling system (among others, detecting defective or congested cooling systems)

- Calculation of estimated hot spot temperature and transformer ageing factor based on prevailing thermal conditions (see Figure 9)
- Recording of historical data (sequence of events, trend curves of load and temperature measurements, etc.)
- Automatic sending of alert e-mails to configured addressees if certain conditions are met. E.g., the oil temperature stayed above a defined level for a defined period of time
- Real audio data to listen to the tap changer operation
- Hyper-links to other relevant information on the Internet, e.g., transformer and tap changer service manuals, user's manuals, vendor support sites, etc.

More detailed information on GLASS is found in [6].

### Disturbance and Breakdown Prediction

Early detection of circumstances which could lead to system faults, and the reliable prediction of the failure probability and its possible impact would be very useful, as preventive measures could be initiated early enough to avoid this failure from materialising or to limit its impact. Typical fault patterns, which eventually lead to power interruptions, depend on a large number of aspects, such as load flow, operating conditions, weather conditions, equipment environmental conditions and wear. Large scale disturbance prediction never really caught on, not at last, because it is almost impossible to develop a reliable model incorporating all these aspects and their mutual dependencies.

The other typical approach would be to analyse the history in order to predict the future. Up to now, this has not been realised because of the sheer amount of utility data, which are residing at different locations in different types of databases. In view of these facts, the interpretation of this data is hardly possible for a person or team to be done. Nevertheless, most utilities have a long record of continuously collecting data of various sort. Within this data are numerous indicators that could help the utility better manage its operation and preventive maintenance. *Data warehousing* and *data mining* are technologies that aim at integrating and analysing large amounts of data to reveal hidden patterns and correlations, which would not have been found otherwise. Their application to the analysis of utility data might help to manage power interruptions in the future.

**Data Warehousing.** Data warehousing stands for the current technology that makes it possible to connect data from different systems, combine them in a separate database (the data warehouse) and approach those data online in a consistent manner [7].

**Data Mining.** Coming from the areas of finance and marketing, data mining is an umbrella term for advanced techniques in the automatic analysis of large quantities of information, typically residing in a data warehouse. Data mining in general, is an approach that applies algorithms to large amounts of data in order to reveal hidden patterns and relationships (e.g. fault patterns,

relationships between weather and operating conditions). As opposed to standard analysis methods, data mining's most interesting ability is to find new profiles, unexpected knowledge, and trends within the base of data, thus helping to spot early trends of various sort, discover problem profiles, customer preferences, etc.

Figure 10 depicts an analysis process based on data mining. The data mining phase provides trends and profiles upon which decisions for actions might be derived and conducted. The collection of new data will then form the new information base to be analysed.

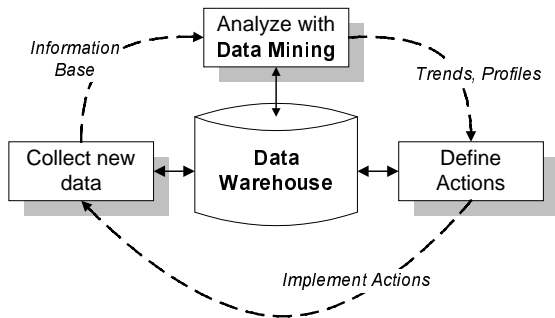

Figure 10: Data Mining within a Full Analysis Cycle

Although it is still a current area of research, data mining's prospects are positive. In the near future, the large amount of available utility data, complemented with other data sources, e.g., obtained from the Internet (like weather), can be analysed, so that it should be feasible to reveal and obtain invaluable information, such as:

- Points of network vulnerability
- Common patterns that lead to power interruptions
- Performance indications of maintenance activities
- Impact of power interruptions (financial, but also delayed resultant problems)
- Information to refine possibly existing risk models
- Information to improve the accuracy of already existing predictive models

## CONCLUSION

The potential benefits outlined in this paper lead to the conclusion that the implementation of most modern technologies for the sake of better system performance and less power interruptions is well justified.

It is the basis that enables advanced control, protection, and monitoring of substations (incl. condition monitoring), as well as fault finding strategies and automatic power restoration. At the end, all contributing to the mitigation of the impact of power interruptions.

## REFERENCES

- [1] A. Poncet, ed., "Condition Monitoring - Principles and Applications", in *ABB Group internal Conference on Control Systems*, 1998
- [2] A. Davies, ed., *Handbook of Condition Monitoring: Techniques and Methodology*, 1<sup>st</sup> edition, Chapman & Hall, London (1998), pp. 503-518
- [3] Cadotsch, C., ed., "Intelligent Load Shedding for Distribution and Industrial Networks", in *CIGRE Regional Meeting - Asia and Middle East*, September 1997
- [4] S. H. Horowitz, ed., "Anatomy of Power System Blackouts: Preventive System Relaying", *IEEE Transactions on Power Delivery*, Vol. 11, April 1996
- [5] W. L. Chan, ed., "Internet Based Transmission Substation Monitoring", *IEEE Transactions on Power Systems*, (approved and recommended manuscript for publication in 1999)
- [6] Pommerell, C., ed., "GLASS: Remote Monitoring of Embedded Systems in Power Engineering", *IEEE Internet Computing*, vol. 2, no 3, May/June 1998, pp. 46-52
- [7] M. Holsheimer, ed., "Marketing and Data Mining Produce a Client Profile", *Data Distilleries B. V.*, 1998