

Mechanical design of a Spherical Grating Monochromator for the Microspectroscopy Beamline PolLux at the Swiss Light Source

Simon Henein¹, Ulrich Frommherz¹, Robin Betemps¹, Herbert Kalt¹,
Urs Ellenberger¹, Uwe Flechsig² and Joerg Raabe²

¹Division of Mechanical Engineering Sciences, Paul Scherrer Institut, 5232 Villigen PSI, Switzerland

²Swiss Light Source, Paul Scherrer Institut, 5232 Villigen PSI, Switzerland

Abstract. This paper describes a new monochromator design for a bending magnet beamline of the Swiss Light Source synchrotron facility. The beamline optics is based on a horizontally deflecting spherical grating monochromator (SGM) with two gratings at a constant deviation angle. It covers a photon energy range from 200 eV to 1000 eV. This paper concentrates on the original flexure-based mechanisms with partially parallel kinematics invented and designed for this monochromator, as well as on the lessons learned from the assembly and testing of the system.

Keywords: Compliant mechanism, flexure, vacuum, monochromator, beamline optics

PACS: 45.40.Ln, 07.85.Qe, 42.79.Dj, 81.40.Pq

INTRODUCTION

This paper describes a new monochromator design developed in the Division of Mechanical Engineering Sciences of the Paul Scherrer Institut (PSI) for a bending magnet beamline of the Swiss Light Source synchrotron facility. The beamline which is called PolLux is a new Fresnel zone plate based scanning transmission x-ray microscopy (STXM) facility. It allows microspectroscopy with sub-micron spatial resolution for polymers, environmental science and magnetism. The beamline is described in detail in the accompanying paper by U. Flechsig et al. [1].

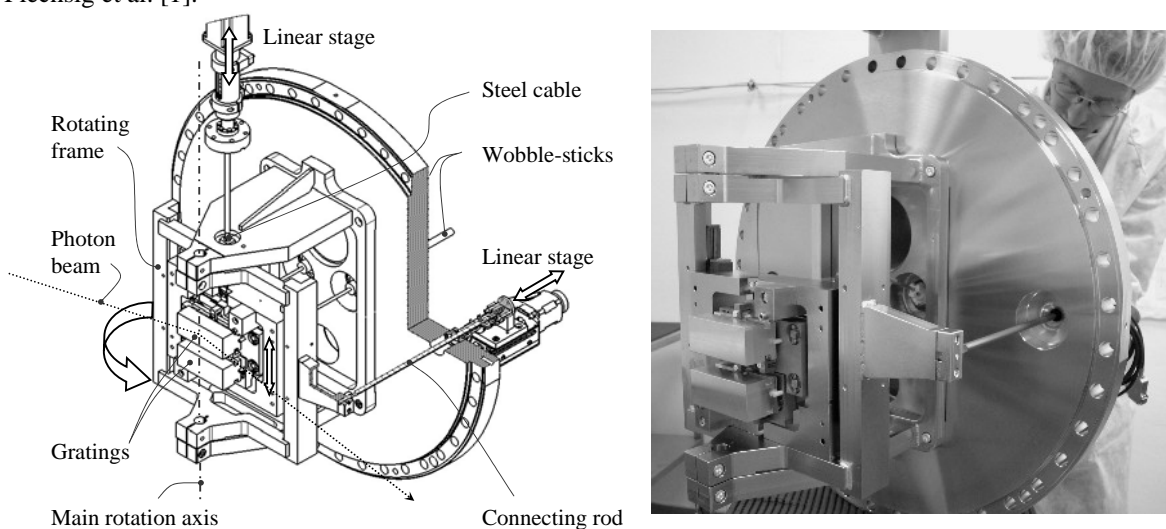

FIGURE 1. Left: drawing of the monochromator showing the main rotation axis as well as the vertical swapping mechanism working in parallel. Right: photo of the monochromator (assembly in PSI's clean room).

The beamline optics is based on a horizontally deflecting spherical grating monochromator (SGM) with two gratings at a constant deviation angle. It covers a photon energy range from 200 eV to 1000 eV.

This paper concentrates on the original kinematics and the mechanical design of the monochromator as well as on the lessons learned from the assembly and testing of the system.

MECHANICAL DESIGN

The monochromator consists of two gratings that can be swapped vertically (motorized motion) to cover the entire desired energy range. The mechanical design of this novel mechanism invented to move the gratings about the desired degrees of freedom is sequentially described in the following sections, starting from the reference plate of the vacuum chamber and ending at the gratings.

Vacuum chamber

The vacuum chamber is based on a COF DN600 flange. It sits on a kinematic mount (3 V-shaped grooves on 3 balls, defining 6 independent contact points) with adjustable feet allowing the positioning of the chamber in the 6 degrees-of-freedom with respect to the reference coordinates of the synchrotron with a resolution better than 0.5mm, respectively 0.5 mrad.

The whole mechanical system has the following properties:

- works in Ultra-High Vacuum (10^{-9} mbar);
- is bakable up to 150 degrees Celsius;
- presents no carbon contamination sources that could alter the optical surfaces (no lubrication is used for any sliding or rolling components of the system).

One of the vertical walls of the chamber is used as precision reference plate for the mounting of the monochromator's mechanisms.

Main rotation axis

The main rotation axis of the monochromator, which is vertical, is defined by two Teldix cross-spring flexure pivots holding a rotating frame (Fig. 1). This axis is actuated by an off-the-shelf linear stage (Phytron ZSS 42.200.1.2 stepper-motor, harmonic drive HD11 (50:1), ball screw and linear bearing Micos PLS-85, Numerik Jena encoder LIA20) that is mounted in air, outside of the vacuum chamber, and transmits its motion to the rotating frame through a bellows with a connecting rod. The latter is made of titanium TiAl6V4 and has two circular notch hinges, one near each extremity. This assembly leads to a very high angular accuracy of 2 micro-radian over a range of 1.2 degrees, with scanning speeds up to 1 mrad/s. This main rotation axis defines the wavelength of the photon beam that reaches the sample at the end of the beamline.

Vertical swapping mechanism

A vertical cross-roller linear bearing is mounted inside the rotation frame. The bearing is actuated by a commercial linear feedthrough unit (Vab vacuum MLS 40-100) that is placed in air, outside of the vacuum chamber, and transmits its motion to the bearing through a bellows and a steel cable. This motion allows the swapping of the gratings. An accuracy of 10 microns is sufficient for this movement.

4 degrees-of-freedom flexure-based mechanism

The vertical linear bearing holds two identical 4 degrees-of-freedom (DOF) flexure-based mechanisms on which the 2 gratings are clamped. The role of these two mechanisms is to make the final fine-alignment bringing the surface of each grating on the main vertical rotation axis of the monochromator (± 1 mm motion range) and then correcting their 3 orientations (yaw, pitch and roll) over ± 10 mrad motion ranges. These mechanisms are driven manually with two wobble-sticks (vacuum screw-drivers) by turning 4 screws per mechanism (one for each DOF). These mechanisms are composed of a Pitch Module and a Yaw-Roll-Y Module that are described below.

The Pitch Module is a 1 DOF Remote-Center-Compliance cross spring pivot that is driven by a cone over an angular range of $\pm 0.5^\circ$ (Fig. 2, left). One of the driving screws drives the cone axially. The cone slides against a pin mounted onto the intermediate platform, which leads to the pitching motion of the grating. The backlash between the cone and the pin is compensated for by the elasticity of the cross-spring pivot.

The Yaw-Roll-Y Module (Fig. 2, right) is based on a simple flexible leaf spring connecting the grating platform to the intermediate platform. The strokes are $\pm 0.5^\circ$ for the two rotations and ± 1 mm for the Y translation. From a flexure's point a view [2], a leaf spring can be considered as a 3 DOFs bearing. These DOFs correspond in our case to the yawing of the grating (natural bending of the spring), the rolling of the grating (torsion of the spring) and the Y translation of the grating (bending in an S shape of the spring). The 3 complementary undesired DOFs are rigidly blocked by the leaf spring. The module is driven by three differential screws that are connected to the mobile platform through 3 flexible rods transmitting the axial movement of the screws while letting free the other movements. The 3 rods are perpendicular to the plane of the leaf spring. Driving all 3 screws by the same amount leads to a translation of the grating along Y. Driving one of the screws alone leads to a rotation of the platform about the axis defined by the 2 other driving rods. Yawing is thus obtained by turning the screw A and rolling by turning the screw B. The differential screws that axially drive the flexible rods combine a pitch of 0.9 mm (UNF thread $\frac{1}{4}$, with a pitch of 0.0357 inch) for the inner thread and a pitch of 1 mm (M8) for the outer thread, which results in a virtual pitch of 0.1 mm per revolution. The backlash of all 3 differential screws is compensated for by a single preload helicoidal spring attached to the centre of the mobile platform, which guarantees that the screws are always loaded in tension.

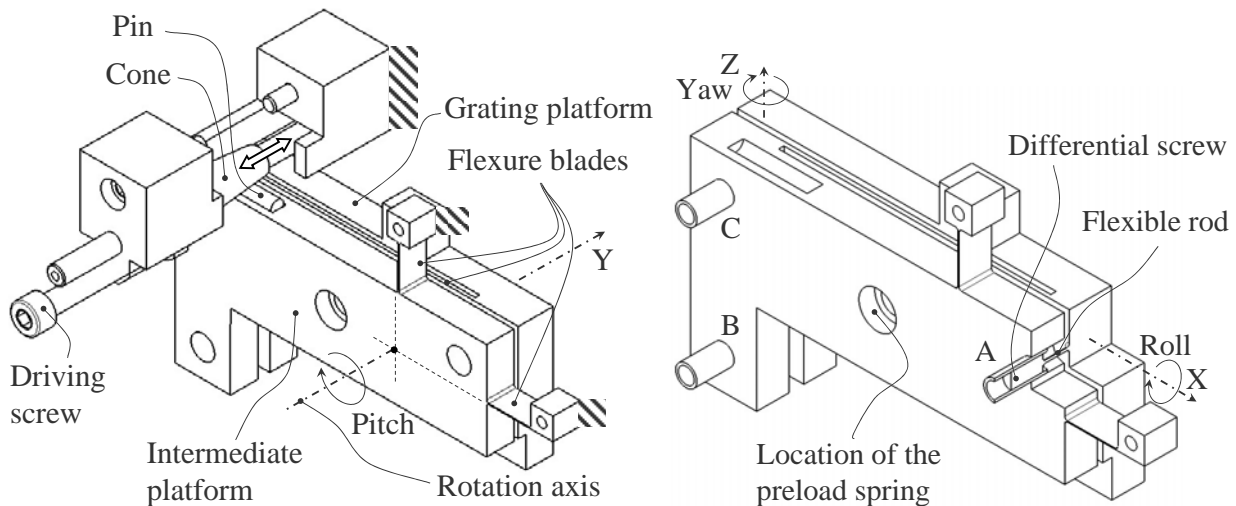

FIGURE 2. Sketches of the 4 degrees-of-freedom flexure-based unit. Left: Pitch Module. Right: Yaw-Roll-Y Module (the drawing of the differential screw is simplified for clarity).

The structure of this unit, including the three flexure blades, is machined monolithically by wire-electrodischarge machining in titanium TiAl6V4. Each grating is kinematically clamped onto its corresponding grating-platform and electrically isolated by ceramic spacers.

The material pairs used for the tribological surfaces [3] are Aluminum-Bronze (CuAl9Fe4Ni1) against Stainless steel (X2CrNiMo18-14-3) (or against Maraging steel X3NiCoMoTi 18-9-5 in the case of the inner male thread with the flexible rod). These material pairs are used without any kind of lubrication in order to avoid any contamination sources that could condense on the optical surface of the grating and alter the optical performance of the monochromator.

Since the maximum torque that can be transmitted through the wobble stick (Ferrovac WM40-100) is limited to 0.5 Nm, a vacuum test has been performed during the design phase to verify that the torque required to turn the differential screws is below this level, which showed to be the case.

TEST RESULTS

The angular measurements have been made in air with a 2 axis autocollimator Elcomat 2000 from Moeller Wedel, with a resolution of 0.05 arcsec. Dummy mirrors have been mounted on the grating-platforms. The measured absolute precision over the 1.2° stroke of the main rotation axis is ± 2 micro-radians.

The repeatability of the angular position after a grating change is better than 5 micro-radians, which indicates that the mechanism is very stable.

The manual grating adjustments have been tested by turning the screws manually by full turns, back and forth. The wobble-stick was always disconnected from the screws during the measurement. The measured Roll bidirectional repeatability is ± 40 arcsec, with a parasitic Yaw motion (cross talk) smaller than 1.5 %. The measured Yaw bidirectional repeatability is ± 15 arcsec, with a parasitic Roll motion (cross talk) smaller than 3 %. The measured Pitch unidirectional repeatability is ± 60 arcsec, with a parasitic Yaw motion (cross talk) smaller than 5 %.

Discussion: the Pitch adjustments have to be performed unidirectionally (i.e. by reaching the goal position coming always from the same direction) to compensate for the backlash between the driving screw and the cone. Moreover, the friction force at the sliding contact point between the cone and the pin results in cross talk effects (parasitic Yaw) which are also compensated for when doing the adjustment unidirectionally. The other DOFs are backlash free and can be driven bidirectionally. Taking these remarks into account, all the performed measurements comply with the specifications of the monochromator.

CONCLUSION

The original mechanical architecture invented to move the two gratings of this monochromator are largely based on parallel kinematics. This approach, which consists in linking the moving organs to the base of the mechanism with several kinematic chains (instead of only chain like in serial kinematics), lead to the following advantages:

- The two linear stages used to swap the grating and to drive the main rotation axis are fixed to the base-plate of the chamber (no mobile motors or sensors), in air. The steel cable (for the vertical swapping motion) and the connecting bar (for the main rotation axis) are used as decoupling kinematic chains that transmit only the desired motion to the gratings, while filtering all the other degrees-of-freedom.
- The three driving differential-screws of the Yaw-Roll-Y Module are all parallel and fixed to the intermediate plate. This allowed using only two wobble-sticks to tune a total of 8 degrees-of-freedom (4 per grating).
- The two gratings are mounted very close to one another thanks to a very compact design. This reduces the stroke of the vertical swapping axis and therefore also the overall size of the monochromator.
- The whole design is very stiff and stable.

The measurements performed on this original system proved that the retained concepts that are based on the combination of flexure-based mechanisms and parallel kinematics give very good results. This architecture is to be recommended for future similar applications.

ACKNOWLEDGMENTS

The authors would like to thank the mechanical workshop of PSI for their commitment in the manufacturing, cleaning and assembly of the whole monochromator, in particular H. Blumer, U. Bugmann, G. Brunner, J. Hovind and M. Heusser. They also thank A. Jaggi and M. Riina for their help during the assembly and testing of the system.

REFERENCES

1. U. Flechsig, C. Quitmann, J. Raabe, M. Böge, R. Fink and H. Ade, "The PoLux Microspectroscopy Beamline at the Swiss Light Source", in the same Proceedings as this article, 2006.
2. S. Henein, "Conception des guidages flexibles", Presses Polytechniques et Universitaires Romandes, CH-1015 Lausanne, 2001.
3. E. W. Roberts (editor), "Space Tribology Handbook", 3rd ed., AEA Technology plc, ESTL, UK, 2002.