

PAPER • OPEN ACCESS

Mobile Urban Micrometeorological Monitoring (MUMiM)

To cite this article: Dasaraden Mauree *et al* 2019 *J. Phys.: Conf. Ser.* **1343** 012014

View the [article online](#) for updates and enhancements.



IOP | ebooksTM

Bringing you innovative digital publishing with leading voices to create your essential collection of books in STEM research.

Start exploring the collection - download the first chapter of every title for free.

Mobile Urban Micrometeorological Monitoring (MUMiM)

Mauree, Dasaraden; Coccolo, Silvia; Deschamps, Laurent; Loesch, Pierre; Becquelin, Paul; Scartezzini, Jean-Louis

Solar Energy and Building Physics Laboratory, Ecole Polytechnique Fédérale de Lausanne CH-1015, Lausanne, Switzerland

dasaraden.mauree@epfl.ch

Abstract. To understand the urban environment from a meteorological perspective in order to design better and more sustainable neighbourhoods, an open-source and low-cost meteorological device was developed and tested at the Ecole Polytechnique Fédérale de Lausanne (EPFL). The results underlined, for example, strong temperature gradients on the campus, particularly in built-up areas with a high density of artificial surfaces. Additionally, the outdoor human comfort was evaluated for multiple locations around the campus, underlying the impact of the urban surfaces as well as the city interface and the greening design. Such studies can be seen as crucial to provide information to stakeholders in the evaluation of their planning strategies either for mitigation (such as decrease of the urban heat island effect or greenhouse gas emissions) or for adaptation (such as improvement of outdoor spaces to face future heat waves).

1. Introduction

Since 2010, urban areas are home to over 50% of the world population [1]. As urban areas concentrate multiple environmental issues (e.g. urban heat island, air pollution, runoff water, etc.), there is thus a strong need to cater for the increasing urban population by improving the air quality, the outdoor thermal comfort and the liveability of cities in general [2,3]. The efficient planning of future buildings and districts will only be possible if urban planners and stakeholders have the appropriate tools and information at their disposition.

This is, however, hardly possible with the available information. On the one hand, models are usually used to evaluate urban planning scenarios, but they do not provide long-term analysis of the scenarios. Moreover, they are computationally very expensive and hence are seldom used by municipalities and urban planners. On the other hand, standardized meteorological data is generally collected outside of cities. There is thus a lack of monitored meteorological datasets for urban areas that could be used by multiple stakeholders. There have been several previous attempts to monitor meteorological variables in cities [4,5]. However, these were performed within the timeframe of a particular project and not extended.

There is thus a need to develop more easy to install and use meteorological instruments. The objective would be to better understand the meteorological dynamics in an urban area. In particular, in this study the monitoring is performed to appreciate and quantify how the students live on a campus, the pathway they take as well as the places where they decide to stay as function of the micrometeorological conditions. The monitoring campaign was performed in the framework of the Master course “Behind and Beyond Future Cities”, in the ENAC faculty of the EPFL.



The rest of the paper is structured as follows: first an overview of the developed instrument is given as well as the methodology chosen for the monitoring campaign. The results obtained are then analysed and discussed. Finally, some conclusions and perspectives for future studies are given.

2. Methodology

2.1 Tool development

An open-source and low-cost meteorological device (MUMiM – Mobile Urban Microclimatic Monitoring) was developed at EPFL to monitor the urban dynamics in particular with relation to the urban heat island phenomena. An air temperature sensor, a humidity sensor, a luxmeter and a sonic anemometer were integrated in the portable device. Additionally, a GPS sensor gave the location of the device at each time step. Most of the hardware are Adafruit components. The specifications of each component are found in Table 1. The MUMiM instruments are portable devices, which can be simply carried by people, moving throughout the urban spaces. The instruments, record all data except wind continuously, providing a complete and coherent profile of the micrometeorological conditions.

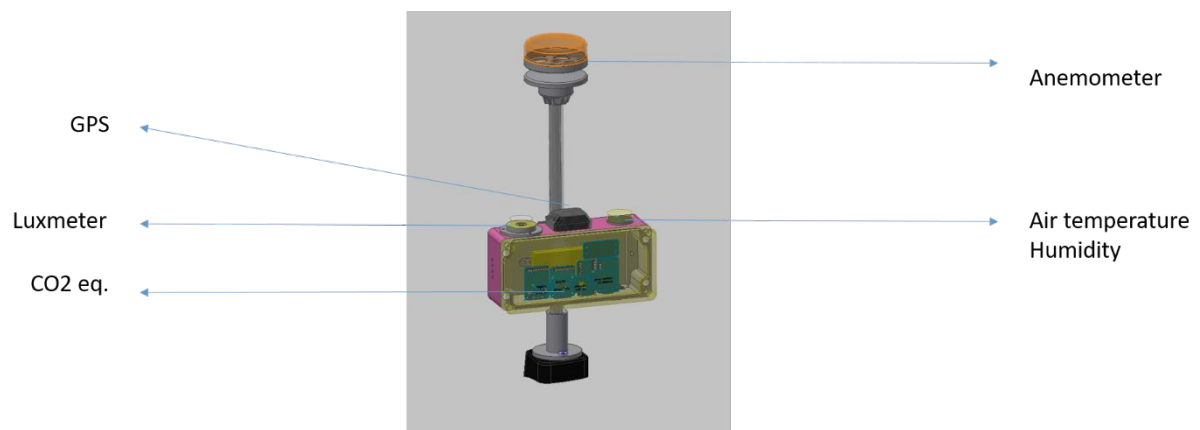

Figure 1. Schematic representation of the MUMiM equipment

Table 1. Technical characteristics of the components

	Brand	Type	Precision	Min	Max	Units
Humidity	Adafruit	SHT31	± 2	0	100	%
Temperature	Adafruit	SHT31	± 0.3	-40	125	$^{\circ}\text{C}$
Luxmeter	Adafruit	TSL2561		0	88000	lux
CO2	Adafruit	SGP30		400	60000	ppm
TOC	Adafruit	SGP30		0	60000	ppb
GPS	Adafruit	Ultimate GPS				
Accelerometer	Adafruit	LM303				
Wind speed	CV7	-E-OEM	0.12	0	n/a	m/s
Wind direction	CV7	-E-OEM	± 1.5	0	360	$^{\circ}$

2.2 Monitoring campaign

Ten groups of students (three to five people each), from the “Behind and Beyond Future Cities” Masters course were equipped with the devices as well as other instruments to make a qualitative assessment of the reliability of the newly developed instrument. and conducted a monitoring campaign on the 11th of April 2019 in the afternoon from 13.30 to 14.30. The monitoring was performed on the EPFL campus in Lausanne (Switzerland). Additionally, the outdoor human comfort was evaluated through measurements of the Wet Bulb Globe Temperature (WBGT) as well as through onsite questionnaires, for multiple locations around the campus, underlying the impact of the urban surfaces, the city interface and the greening design. The final objective of the study was to create a climatic map of the EPFL campus, by interposing the monitoring data performed by the students.



Figure 2. Different monitored environment on the EPFL campus

3. Results and Discussions

The air temperature and the relative humidity from four selected instruments are shown in Figure 3 and Figure 4 respectively.

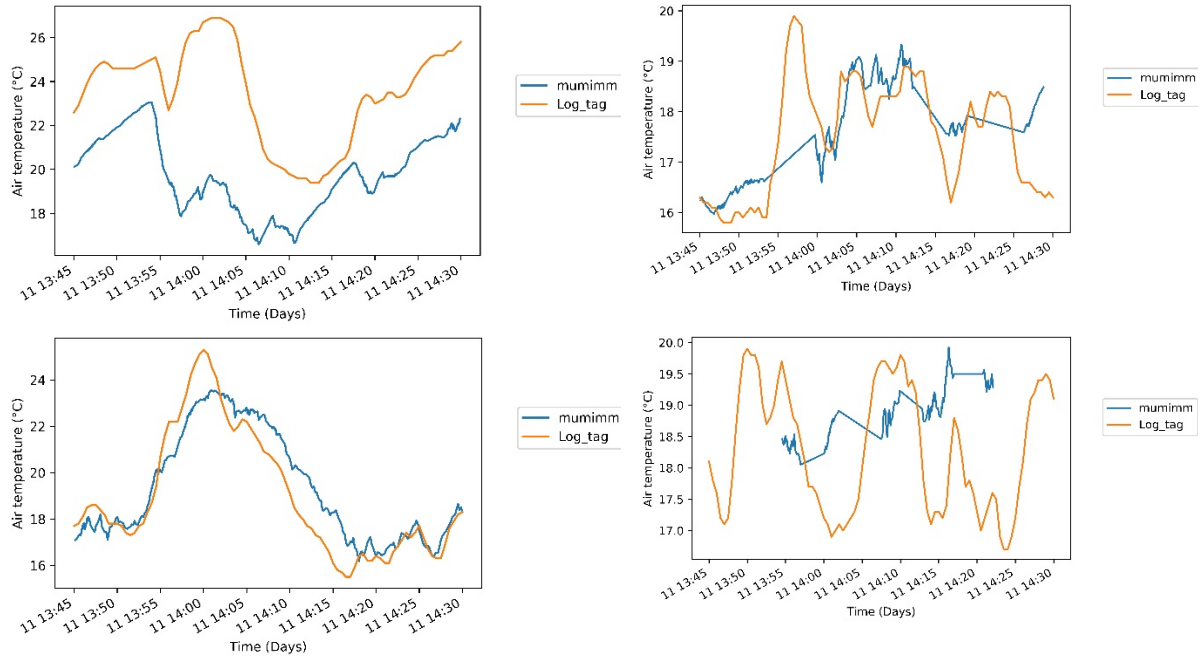

Figure 3. Air temperature (°C) measured by the MuMiM instrument and the LogTag (from left to right and top to bottom: Instrument #1, #3, #6 and #10)

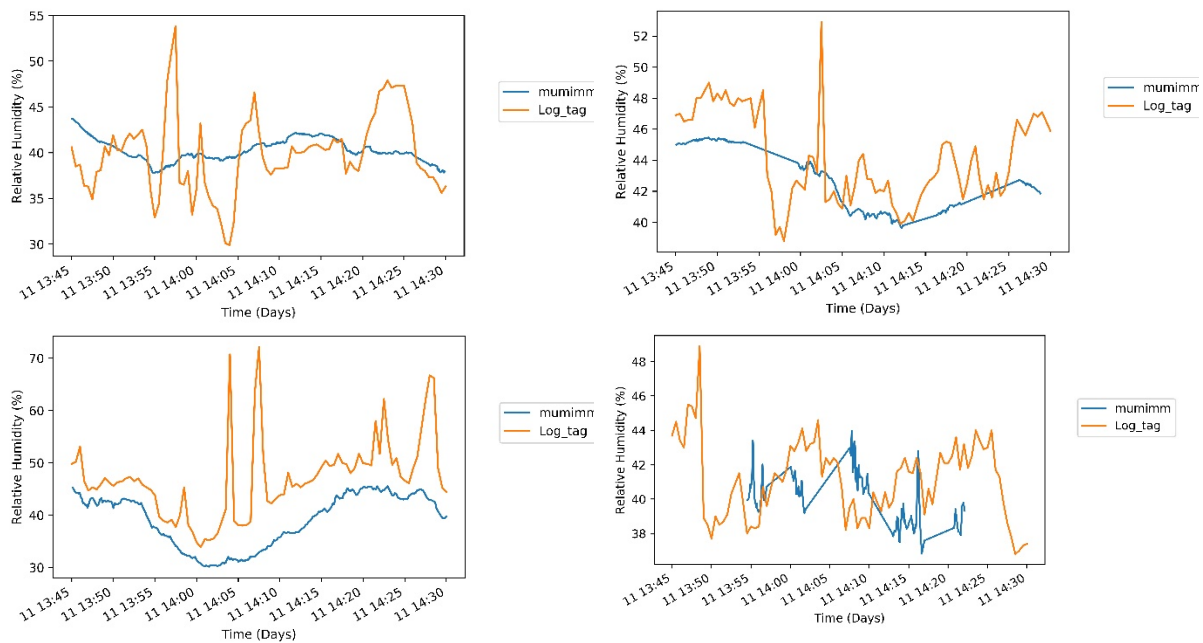

Figure 4. Relative humidity (%) measured by the MuMiM instrument and the LogTag from left to right and top to bottom: Instrument #1, #3, #6 and #10)

It can be seen that on average the MuMiM recordings for the temperature and the humidity are relatively similar to those of the LogTag (which is a commercial, standard and calibrated instrument used regularly). Several features from the measurement can be explained with the handling of the instruments themselves. Some of the participants switched the instrument on and off during the measurement period. This is noted in the graphs with the linear interpolation between 2 points and is particularly noticeable from the comparison of instrument #10 with the LogTag. Furthermore, it can be highlighted that for instrument #1 the temperature was underestimated by the MuMiM instrument with an average difference of 3.7°C . Such a marked behaviour was not noted in other instruments and did not appear also in the relative humidity readings.

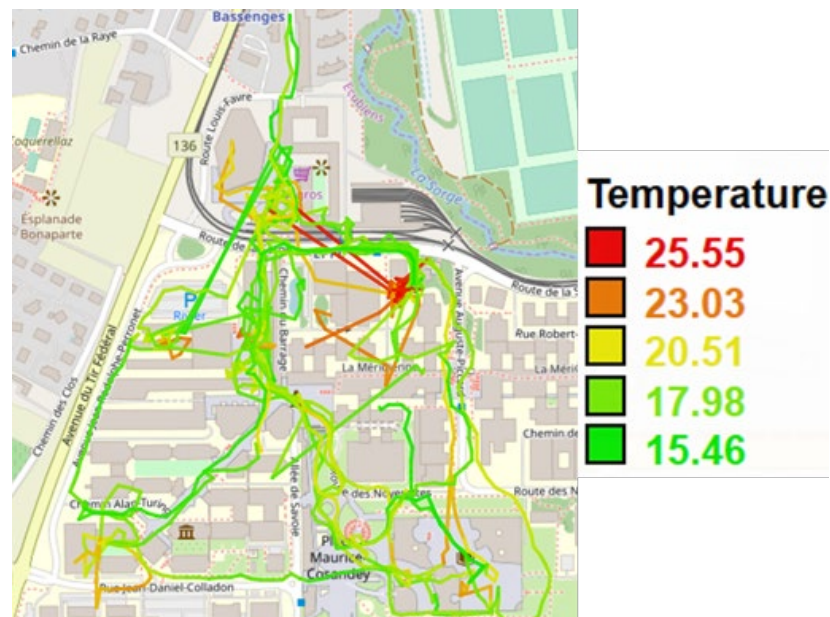

Figure 5. Map of the temperature ($^{\circ}\text{C}$) for the EPFL campus combining all instrument used for the monitoring on the 11th April 2019 from 13.30 to 15.30

Figure 5 gives an example of a map that can be created using the measurement obtained from the instruments. Overheating can be noted overall in denser areas of the campus, while in more open spaces and places with a higher fraction of vegetation, the measured air temperatures are slightly lower. This is in accordance with previous studies conducted on the campus [6,7] or in the region [8]. Within the monitoring day, circa 10 monitoring datasets were obtained thereby allowing a good description of the urban microclimatic conditions on that day within the EPFL campus.

4. Conclusions and Perspectives

A new open-source and open hardware meteorological instrument was developed at the EPFL. This instrument can be used to analyse the urban outdoor environment in order to derive new urban planning strategies. The first measurement campaign conducted during Spring 2019 gave satisfactory results as regards to the validity of the measurement. The results further underlined, for example, the strong temperature gradients that exist on the campus, particularly in built-up areas with a high density of artificial surfaces. Comparisons with standard instruments were also made for all variables measured (such as the wind speed, wind direction, CO_2 ,...) and will be published in a next study. It should be noted that the instruments used for the comparison had different response time. The largest difference in the response time was between the CO_2 sensors that we used (results not shown here). For the wind, the sonic anemometers only took measurements in stationary conditions with a sampling rate of 1 s. The

Logtag on the other hand took measurement every 10 s as did the MuMiM sensor for the temperature and RH.

In the future, the objective is to extend the monitoring campaign to multiple urban areas to improve the understanding of the urban heat and cool island effect, in particular due to the presence of the nearby Lake Lemán. Such studies can be seen as crucial to provide information to stakeholders in the evaluation of their planning strategies either for mitigation (such as decrease of urban heat island or greenhouse gas emissions) or for the adaptation (such as improvement of outdoor spaces to face future heat waves). Moreover such instruments can be used to raise awareness of environmental problems, in order to people urban dwellers understand and address these issues in their daily life.

Acknowledgements

This research project has been financially supported by the Swiss Innovation Agency Innosuisse and is part of the Swiss Competence Center for Energy Research SCCER FEEB&D. The MuMiM equipment was funded by the ENAC Faculty of the Ecole Polytechnique Fédérale de Lausanne under the scientific equipment scheme. The authors would also like to sincerely thank all the students of the Master's course AR496 for their contribution in the measurements: Alami Idrissi Souheil, Arnaudon Lucie, Beike Sophie Charlotte, Beuret Timothé Pablo, Chalumeau Sophie Marion, Chastonay Anouk Hélène Myriam, Ché Carmen, Chen Fei Ya, Clement Anna Lydie, Cristea Thomas Horia, Crot Julie, D'Antonio Grégory David, Dagand Charlotte Louise, Diale Norberto, Dias Elodie, Ferrero Alfredo, Fleischner Ludovic Ronald Stanley, Gandor Anne-Claire Amélie Claudine, Habermeyer Lucas Johannes, Hirsztritt Zuzanna, Huber Lena, Hürlimann Eva, Ishii Andrea Hiroki, Jashari Valdrin, Kalaitzidis Nikos Alexandros, Lauriere Elliot Casimir Jean-Pól, Masson Lauriane Hélène, Mayr Theresa Lydia, Morisseau Yann Paul, Mouradian Alex Vahagn, Niepieklo Sara Anna, Östberg Ebba Maritha Pernilla, Pirro Giulia, Reineke Anna Giulia, Roche-Meredith Charlotte, Sadler Mui Justine, Schneider Melanie Jasmin, Schröder Felix Shi-Yen, Shoji Kanaha, Ulsund Solveig Askevold and Yildirim Serra.

References

- [1] UN 2012 *World Urbanization Prospects: The 2011 Revision, CD-ROM Edition* (United Nations)
- [2] Baklanov A, Grimmond C S B, Carlson D, Terblanche D, Tang X, Bouchet V, Lee B, Langendijk G, Kolli R K and Hovsepian A 2017 From urban meteorology, climate and environment research to integrated city services *Urban Climate*
- [3] Bai X, Dawson R J, Ürge-Vorsatz D, Delgado G C, Barau A S, Dhakal S, Dodman D, Leonardsen L, Masson-Delmotte V, Roberts D C and Schultz S 2018 Six research priorities for cities and climate change *Nature*
- [4] Rotach M W, Vogt R, Bernhofer C, Batchvarova E, Christen A, Clappier A, Feddersen B, Gryning S-E, Martucci G, Mayer H, Mitev V, Oke T R, Parlow E, Richner H, Roth M, Roulet Y-A, Ruffieux D, Salmond J A, Schatzmann M and Voogt J A 2005 BUBBLE – an Urban Boundary Layer Meteorology Project *Theoretical and Applied Climatology* **81** 231–61
- [5] Mauree D, Deschamps L, Becquelin P, Loesch P and Scartezzini J-L 2017 Measurement of the impact of buildings on meteorological variables *Building Simulation Applications, BSA 2017* 273–8
- [6] Mauree D, Coccolo S, Kaempf J and Scartezzini J-L 2017 Multi-scale modelling to evaluate building energy consumption at the neighbourhood scale *PLOS ONE* **12** e0183437
- [7] Mauree D, Coccolo S, Kämpf J and Scartezzini J-L 2016 Multi-scale modelling to assess human comfort in urban canyons *Expanding Boundaries - Systems Thinking in the Built Environment - Proceedings of the Sustainable Built Environment (SBE) Regional Conference Zurich 2016*
- [8] Coccolo S, Kaempf J, Mauree D and Scartezzini J-L 2018 Cooling potential of greening in the urban environment, a step further towards practice *Sustainable Cities and Society*