

# A verification of CitySim results using the BESTEST and monitored consumption values

Walter Emmanuel – kaemco LLC, La Riaz 6, 1426 Corcelles-Concise, Switzerland – ew@kaemco.ch

Kämpf Jérôme – LESO-PB / EPFL, Station 18, 1015 Lausanne, Switzerland – jerome.kaempf@epfl.ch

## Abstract

This paper presents a verification of CitySim, a large-scale building energy simulation tool based on a simplified thermal model. First, the main assumptions behind the simplified model are presented. Then, CitySim is compared to other detailed simulation tools on case studies defined in the Building Energy Simulation Test (BESTEST) validation procedure. Finally, the predictions of CitySim regarding the annual heating load are compared with the monitored consumption of a building located on the campus of the Swiss Federal Institute of Technology Lausanne (EPFL). Regarding the BESTEST, CitySim gives annual heating and cooling results together with peak heating and cooling loads that are within the acceptable range defined by reference simulation tools except for the annual heating load of case 960 and the peak cooling of case 610 but the differences are rather small (less than 1%). Regarding the EPFL campus building, CitySim gives an annual heating consumption within a 5% range of the monitored consumption of two reference years. The paper concludes that despite its simplified thermal model, CitySim results remain consistent with more detailed programs and the monitored heating consumption of an office building. These results reinforce the confidence in the tool to predict annual and peak load energy needs for conditioning buildings.

## 1. Introduction

According to UN and IEA forecasts (UN, 2011) and (IEA, 2008), the urbanized population is expected to grow tremendously in the future and likewise their fossil fuel energy consumption. To moderate this non-renewable energy consumption in urban areas, shelters must be planned, designed and refurbished in an efficient way.

With this aim in mind, CitySim (Kämpf, 2009), a large-scale dynamic building energy simulation tool, was developed at the Swiss Federal Institute of Technology Lausanne (EPFL). The tool includes an important aspect in the field of many buildings simulation: the building interactions (shadowing, light inter-reflections and infrared exchanges). Furthermore, CitySim is based on simplified modelling assumptions to establish a trade-off between input data needs, output precision requirements and computing time. These simplifications may be the cause of possible over or underestimations in the program outputs. The objective of this paper is to make sure that CitySim gives reasonable results despite the simplifications. According to (Judkoff, 1988), a complete validation methodology for building energy simulation programs is composed of three main pillars: the analytical verification, the comparative testing approach and the experimental verification.

The first pillar consists in comparing the program with a known analytical solution, which was already applied on CitySim in its initial developments (Kämpf, 2009).

This paper addresses the two other approaches: CitySim is confronted to more detailed simulations tools within the frame of the Building Energy Simulation Test (BESTEST) method (Judkoff and al., 1995) and its accuracy is verified experimentally by a comparison with monitored data for an EPFL campus building.

## 2. CitySim building model

This paragraph briefly illustrates the characteristics of the simplified thermal model used within

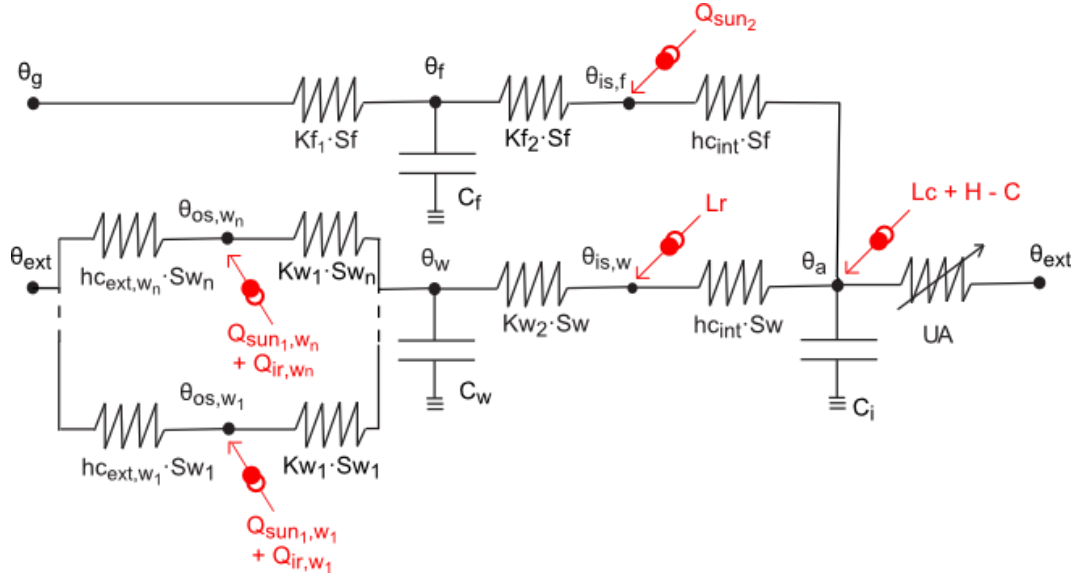

Fig. 1 - The four node thermal model as an equivalent electric circuit not showing the roof node for simplification (roof node similar to wall node)

CitySim. The building envelope is composed of three surface types: the floors, walls and roofs, each of which is considered to have a homogeneous temperature. A building thermal zone can therefore be represented by a four node model (see Fig. 1), in which the light materials of a room (air and furniture) are represented by a node of temperature  $\theta_a$  (°C) and capacitance  $C_i$  (J/K). This node is connected to the exterior air temperature  $\theta_{ext}$  (°C) through a conductance representing the windows and the air infiltration/ventilation  $UA$  (W/K). Furthermore, the node  $\theta_a$  receives the convective internal gains  $Lc$  (W) and the heating  $H$  (W) and cooling  $C$  (W) loads.

The floor is represented by a node of temperature  $\theta_f$  (°C) and capacitance  $C_f$  (J/K). The total floor surface  $S_f$  (m<sup>2</sup>) is taken into account to compute the conductances to the interior surface temperature  $\theta_{is,f}$  (°C) and the ground temperature  $\theta_g$  (°C) through the specific conductances:  $Kf_1$  and  $Kf_2$  (W/(m<sup>2</sup>·K)). The internal surface convection coefficient  $hc_{int}$  (W/m<sup>2</sup>·K) is considered to be the same for all kind of surfaces and equal to 3 W/(m<sup>2</sup>·K) (CIBSE guide).  $Kf_1$  and  $Kf_2$  are calculated using eq. 1 and 2 for a floor of  $l$  different layers each of which being represented by a capacitance  $C_j$  (J/K) and a conductance  $K_j$  (W/(m<sup>2</sup>·K) where  $j = 1..l$  (Lorentz and al., 1982).

$$Kf_1 = \frac{\sum_{j=1}^l C_j}{\sum_{j=1}^l C_j \cdot \left( -\frac{1}{2} \frac{1}{K_j} + \sum_{i=1}^j \frac{1}{K_i} \right)} \quad (1)$$

$$Kf_2 = \left( \sum_{j=1}^l \frac{1}{K_j} - \frac{1}{Kf_1} \right)^{-1} \quad (2)$$

The transmitted light flux through the glazed surfaces  $Q_{sun2}$  (W) is considered to reach the floor internal surface node.

The walls and roofs consisting of  $m$  and  $n$  surfaces are defined in a similar way to the floors, except that each different wall and roof surface has its own outside surface temperature node respectively  $\theta_{os,w_i}$  and  $\theta_{os,r_j}$  with  $i=1..m$  and  $j=1..n$  and a distinct area (respectively  $Sw_i$  and  $Sr_j$  with  $i=1..m$  and  $j=1..n$ ). Finally, the exterior wall and roof surface convection coefficients  $hc_{ext,w_i}$  and  $hc_{ext,r_j}$  (W/(m<sup>2</sup>·K)) depend on the wind speed and direction impinging on each wall ( $i=1..m$ ) and roof ( $j=1..n$ ) surfaces. Temperature computations are influenced by radiant and convective exchanges through source terms in the energy balance of the thermal nodes:  $\theta_{os,w_i}$  and  $\theta_{os,r_j}$  (°C) depends on the absorbed incident light flux ( $Q_{sun1,w_i}$  and  $Q_{sun1,r_j}$  in watts) and on the infrared energy flux exchange ( $Q_{ir,w_i}$  and  $Q_{ir,r_j}$  in watts).

### 3. Methodology

#### 3.1 Comparative testing approach: BESTEST procedure application

The Building Energy Simulation Test (BESTEST) is a series of test suites developed by the US National Renewable Energy Laboratory, the International Energy Agency and the US Department of Energy. The approach is to compare a candidate program with a set of reference programs that represent the state-of-the-art of building simulation on a series of simulation benchmark test cases. The aim is to identify major errors in the software package.

In this paper, the ability of CitySim to correctly simulate the building envelope is investigated using the IEA BESTEST suite (Judkoff and al., 1995). In this suite, the reference kernel is composed of ESP (UK), BLAST 3.0 Level 215 (USA), DOE2.1E-W54 (USA), SERIRES/SUNCODE (USA), SERIRES-1.2 (USA), S3PAS (Spain), TRNSYS (USA) and TASE (Finland).

The base case (600) is a rectangular single room building whose main characteristics are presented in Table 1 and illustrated in Fig. 2. The base case is declined in subcases (610 to 960) with different subsequent changes in the building mass, the windows orientation and shadings summarized in Table 2.

The comparison is carried out on the annual heating and cooling loads and the annual peak heating and cooling loads considering an ideal heating and cooling control system. The comparison is done in sequence, case-by-case, for each output categories. The distribution of the reference programs results defines a validity range in which CitySim results should fall to pass the test.

The main assumptions that were made for the simulation of the test cases are as follow:

- The climate file available in the online resources of the BESTEST does not include the diffuse horizontal irradiance that is required for CitySim simulations. This value is therefore recalculated using the sun altitude and position given by CitySim. Values for the cloud cover fraction, the relative humidity and the precipitations are extracted from Meteororm for the Denver location.

- The floor insulation thickness is very large in the BESTEST to reduce the heat flux to the ground. For CitySim simulations, the density and specific heat capacity of this insulation materials is chosen to be  $1 \text{ kg/m}^3$  and  $100 \text{ J/(kg}\cdot\text{K)}$  respectively similarly to the assumptions taken during ESP-r validation (ESP-r, 2015).

- In the definition of the BESTEST, 3.5% of transmitted solar gains is lost through the windows (reflected back outside of the room). The glazing g-value is therefore decreased by 3.5% to represent this effect.

- The Air Change per Hour (ACH) is corrected to take into account the variation of air density with altitude.

- Other diagnostic cases (195 to 440 and 800 to 810) defined in the IEA BESTEST suite that consider the variation of the shortwave reflectance and long-wave emissivity coefficients, internal heat gains, air change per hour and windows U-values were executed but are not presented in this paper.

- Tests including advanced control strategies for ventilation (650 and 950) and temperature set-points setback (640, 940) are not modelled with CitySim as the tool was not aiming at addressing control strategies. The ground coupling case (990) is also not carried out as it is irrelevant for CitySim simulations.

Table 1 - BESTEST base case building description

Dimensions	$L = 8\text{m}, P = 6\text{m}, h = 2.7\text{m}$
Envelope	$U_{\text{wall}} = 0.514 \text{ W}/(\text{m}^2\cdot\text{K})$ $U_{\text{roof}} = 0.318 \text{ W}/(\text{m}^2\cdot\text{K})$ $U_{\text{floor}} = 0.039 \text{ W}/(\text{m}^2\cdot\text{K})$
Air renewal	$0.5 \text{ h}^{-1}$
Internal gains	$200 \text{ W}$ (60% radiation, 40% convection)
External short-wave absorbance	$0.6 [-]$
External long-wave emissivity	$0.9 [-]$
Windows	$U_{\text{windows}} = 3 \text{ W}/(\text{m}^2\cdot\text{K})$ $g\text{-value} = 0.72129 [-]$
System	Ideal air heating and cooling
Setpoint	$T_{\text{min}} = 20^\circ\text{C}, T_{\text{max}} = 27^\circ\text{C}$

Table 2 - BESTEST cases definition

Case	Description
600	Base case, Lightweight envelope, 2 windows of 6 m <sup>2</sup> of the south façade
610	Case 600 with 1 m overhang on the south
620	Case 600 windows on east and west
630	Case 620 with 1m fins and overhangs
900	Case 600 with heavy inertia envelope
910	Case 610 with heavy inertia envelope
920	Case 620 with heavy inertia envelope
930	Case 630 with heavy inertia envelope
960	Multizone case (unheated sun-zone on the south side)

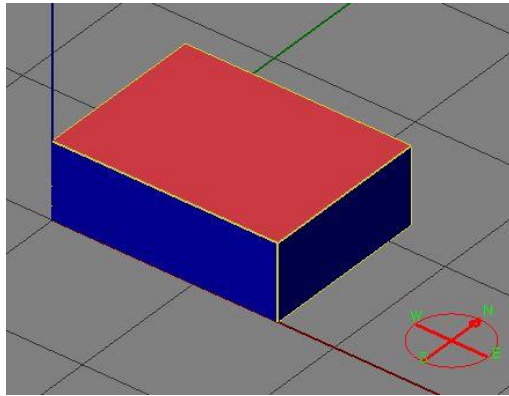

Fig. 2 - BESTEST base case geometry in CitySim Designer

Considering the above mentioned assumptions, CitySim results are compared within the frame of the BESTEST procedure.

### 3.2 Experimental verification: Simulation of an EPFL campus building

The predictions of CitySim are compared with the monitored consumption of the LE building located on the EPFL campus. The LE building was built in 1977 for the School of Architecture, Civil and Environmental Engineering and is composed of two main entities: the South zone is considered as an office space and the North zone as a store house (see Fig. 3).

The 3D digital model of the building geometry is based on the work of Carneiro (2011). The weather file is obtained from the Meteonorm software (Meteonorm, 2014) for Ecublens city in which the building is located. The typical meteorological year taken into account is an average of temperatures

over the years 2000 to 2009, and an average of the radiation (direct solar and diffuse) over the years 1991 à 2010. The construction materials were defined by Morel (2004) and from the building plans available at the Real Estate and Infrastructure Department of the school (DII). Associated thermal conductivity, density and specific heat are extracted from LESOSAI material database (Material-db, 2014). The internal heat gains and the air renewal rates are determined using the characteristics of an office and storehouse as defined in the SIA norm (SIA, 2006). The setpoint definition is taken from a previous study on the EPFL campus (Helms, 2009). The glazing ratios of the different facades are estimated using pictures of the building such as Fig. 4. The different building characteristics are summarized in Table 3.

Table 3 – LE building description

Envelope	$U_{wall} = 0.207 \text{ W}/(\text{m}^2\cdot\text{K})$ $U_{roof} = 0.174 \text{ W}/(\text{m}^2\cdot\text{K})$ $U_{floor} = 0.526 \text{ W}/(\text{m}^2\cdot\text{K})$
Air Change per Hour	$ACH_{offices} = 0.3 \text{ h}^{-1}$ $ACH_{storehouse} = 0.14 \text{ h}^{-1}$
Occupants and equipments maximal density (associated schedules in documentation)	Office $Q_{occ} = 14 \text{ m}^2/\text{pers}$ $Q_{equ} = 7 \text{ W}/\text{m}^2$ Storehouse $Q_{occ} = 40 \text{ m}^2/\text{pers}$ $Q_{equ} = 0 \text{ W}/\text{m}^2$
SW abs, LW em	0.8 [-], 0.93 [-]
Windows	$U_{windows} = 1.4 \text{ W}/(\text{m}^2\cdot\text{K})$ $g\text{-value} = 0.7 [-]$
Setpoint	$T_{min} = 21.5^\circ\text{C}$



Fig. 4 - Picture of the LE South façade (credits: CHABOD Louis, 21.10.2012)

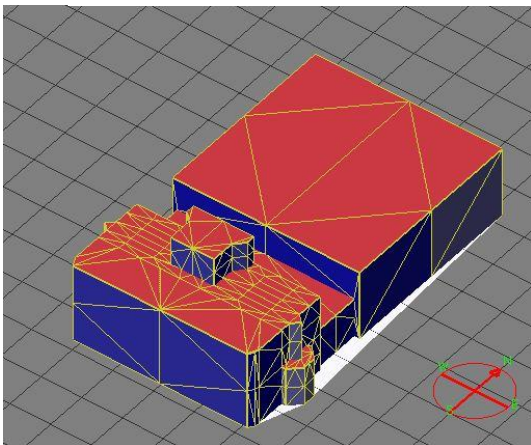

Fig. 3 – LE building in CitySim Designer

## 4. Results and discussion

### 4.1 Comparative testing approach

The results of the BESTEST are presented in Fig. 5. On the considered cases, CitySim outputs are consistent with those of more detailed programs. The results for the annual heating are rather concentrated around the lower limit of the validity range. Those results are close to the ones of ESP which is not a surprise as CitySim was initially compared to ESP-r in its early developments (Kämpf, 2006). Results for peak heating are close to

the middle of the validity range in all cases.

CitySim outputs for the annual cooling are close to the high limit of the range, in particular for cases 900 to 930 that have a heavyweight envelope. The peak cooling is rather on the low end of the range in all cases. Exception cases, peak cooling (610) and annual heating load (960) are outside the range by approximately 0.14% and 0.53%, but these errors are rather small.

The application of the BESTEST methodology on CitySim revealed that hypothesis concerning the windows are critical. In particular, it showed the necessity to vary the glazing g-value according to the solar angle of incidence. In cases with shadings (610, 630, 910, 930), considering the exact windows shape and position rather than just a glazing to wall ratio permitted to improve significantly the results.

Concerning the envelope, the tests showed that the thermal inertia of the floor and roof have a major effect on the inside air temperature regulation.

Considering those results, CitySim can be considered as validated by the BESTEST protocol and therefore comparable to more detailed programs.



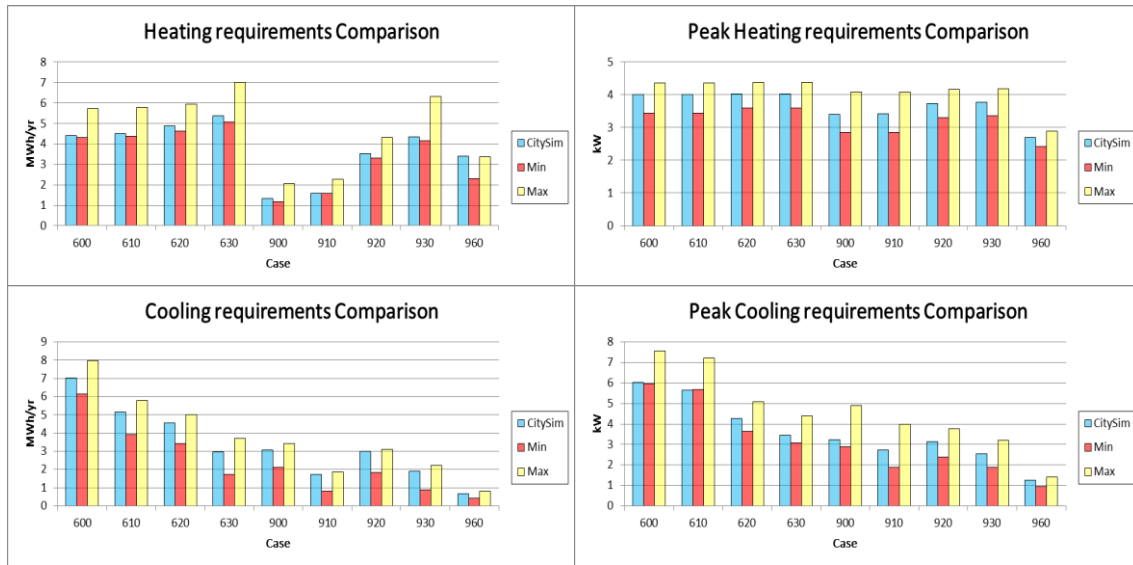

Fig. 5 - BESTEST results for the annual heating and cooling loads and the peak heating and cooling requirements

## 4.2 Experimental verification

Table 4 summarizes the results of monitoring of the annual heating consumption and simulation for the LE building of the EPFL. The heating demand in 2013 is 0.6% lower than the predicted consumption. In 2012, the gap increases to 5.1%. In both cases, CitySim result is over the monitored consumption.

Table 4 - Heating consumption prediction and monitored values

CitySim result	152 651 kWh
Heating 2012	145 237 kWh (-5.1%)
Heating 2013	151 693 kWh (-0.6%)
Average consumption (2012-2013)	148 465 kWh (-2.8%)

This result illustrates that CitySim results are consistent with reality. However, one may question consistency of the hypothesis on which the model is based. Indeed, the weather file obtained from Meteonorm is an average of several different years. There is no guarantee that these climatic data correspond to the actual climate in 2012 and 2013. Differences in temperature or irradiation could alter significantly the heating consumption.

The SIA norm represents a standard in Switzerland but might not well represent the occupation schedule of a campus building. Indeed, the scheduled presence of internal gains due to occupants and equipment does not include particular period such as week-ends or holidays.

Furthermore, the effects of occupants' stochastic behaviour such as windows opening are not taken into consideration. This effect can be significant in middle season periods. Finally, the air tightness of the envelope (through wall cracks and window joints) decreases after years of operation.

Moreover, the definition of a 21.5°C inside temperature set-point, which is a volumetric average between heated and unheated zones, may not be constant throughout the year as occupants have individual choices of temperature set-points in the different office rooms.

The effect of the separating walls' thermal mass is neglected in the CitySim model, which is not a bad approximation as the separating walls are lightweight structures.

Considering the above mentioned assumptions, the LE building was quickly modelled using CitySim with a limited number of parameters. The obtained results were shown to be consistent with monitoring. However, only the annual heating consumption of the LE building could be compared, limiting the scope of this experimental validation. This being due to the fact that the building is located in a cold dominated climate and is not equipped with air conditioning system. Furthermore, the monitoring of the building was not available on an hourly basis, making impossible the comparison with peak heating requirements.

## 5. Conclusion

In this paper, the results of a large-scale building energy simulation tool called CitySim, which uses a simplified building model to reduce data input requirements and computing time, are verified using two distinct methodologies.

First, the tool is shown to produce results comparable to those of more detailed programs by applying the BESTEST comparative testing approach. Only a couple of errors arose on the simulation of the peak cooling demand (610) and the heating load (960). However, those differences only diverge from the expected result by less than 1%. CitySim can therefore be considered as validated by this BESTEST procedure.

Then, the accuracy of the tool is verified experimentally by comparing the program outputs with the monitoring of the annual heating consumption of an EPFL campus building. The difference in results is around 5% with broad hypothesis.

CitySim therefore proved to be a reliable tool for quickly determining the heating and cooling needs of buildings for design and retrofit stages. Therefore, this program could have a role to play in mitigating the foreseen energy consumption increase in the urban context due to the growth of urbanized population.

## 6. Acknowledgement

Many thanks to kaemco LLC for providing help, funding and technical support for the CitySim software. Thanks to the DII department of EPFL for providing the necessary documentation and data.

## 7. Nomenclature

ACH	Air Change per Hour
C	Cooling power
$C_f$	Capacitance of the floor
$C_i$	Capacitance of the inside air
$C_j$	Capacitance of layer j
$C_w$	Capacitance of the wall
g-value	Solar energy transmittance of glass

h	BESTEST Building height
H	Heating power
$hc_{int}$	Internal convection exchange coefficient
$hc_{ext,w_i}$	External convection exchange coefficient of roof surface j
$hc_{ext,w_i}$	External convection exchange coefficient of wall surface n
$Kf_1$	Specific floor conductance to the exterior of the thermal zone
$Kf_2$	Specific floor conductance to the interior of the thermal zone
$K_j$	Specific conductance of layer j
$Kw_1$	Specific wall conductance to the exterior of the thermal zone
$Kw_2$	Specific wall conductance to the interior of the thermal zone
L	BESTEST base case length
$L_c$	Convective internal gains
$L_r$	Radiative internal gains
P	BESTEST base case width
$Q_{ir,r_j}$	Longwave light flux exchange on roof surface j
$Q_{ir,w_n}$	Longwave light flux exchange on wall surface n
$Q_{sun_1,r_j}$	Absorbed incident light flux on roof surface j
$Q_{sun_1,w_n}$	Absorbed incident light flux on wall surface n
$Q_{sun_2}$	Light flux transmitted to the interior
$Q_{occ}$	Occupants density
$Q_{equ}$	Equipment density
$S_f$	Total surface of the floor
$S_{r_j}$	Area of roof surface j
$S_{w_n}$	Area of wall surface n
$S_w$	Total surface of the wall
$\theta_a$	Inside air temperature
$\theta_{ext}$	External air temperature
$\theta_f$	Temperature of the floor
$\theta_g$	Temperature of the ground
$\theta_{is,f}$	Floor inside surface temperature
$\theta_{is,w}$	Wall inside surface temperature
$\theta_{os,r_j}$	Outdoor temperature of roof surface j
$\theta_{os,r_n}$	Outdoor temperature of wall surface n
$\theta_w$	Wall temperature
UA	Window and infiltration/ventilation

	conductances
$U_{\text{floor}}$	Thermal conductivity of the floor
$U_{\text{roof}}$	Thermal conductivity of the roof
$U_{\text{wall}}$	Thermal conductivity of the wall

## References

- Carneiro, C. 2011. *Extraction of Urban Environmental Quality Indicators using LiDAR-Based Digital Surface Models*. Ph.D. Thesis. Swiss Federal Institute of Technology. Switzerland
- DII. 2008. *Bilan des énergies du site de l'EPFL à Ecublens 2007*. Swiss Federal Institute of Technology. Switzerland.
- ESP-r, 2015, Accessed January 15 <https://espr.svn.cvsdude.com/esp-r/>
- Helms, T. 2009. *Energy System Analysis of a University Campus: Energy consumption and efficiency measures for the Ecole Polytechnique Federal Lausanne (EPFL)*. Swiss Federal Institute of Technology. Switzerland
- IEA 2008. *World Energy Outlook 2008*. International Energy Agency
- Judkoff, R. 1988. "Validation of Building Energy Analysis Simulation Programs at the Solar Energy Research Institute." *Energy and Buildings* 10: 221-239. doi: [10.1016/0378-7788\(88\)90008-4](https://doi.org/10.1016/0378-7788(88)90008-4).
- Judkoff, R. Neymark, J. 1995. *International Energy Agency building energy simulation test (BESTEST) and diagnostic method*. Golden: National Renewable Energy Laboratory. United States
- Kämpf, J. Robinson, D. 2006. "A simplified thermal model to support analysis of urban resource flows." *Energy and Buildings* 38: 445-453. doi: [10.1016/j.enbuild.2006.09.002](https://doi.org/10.1016/j.enbuild.2006.09.002).
- Kämpf, J. 2009. *On the modelling of Urban Energy Fluxes*. Ph.D. Thesis. Swiss Federal Institute of Technology. Switzerland
- Lorenz, F. Masy, G. 1982. *Méthode d'évaluation de l'économie d'énergie apportée par l'intermittance de chauffage dans les bâtiments. Traitement par différences finies d'un modèle à deux constantes de temps*. Technical report, Building physics Laboratory, Liège University.
- Material-db, 2014. Accessed September 19 <http://www.materialsdb.org/>
- Meteonorm, 2014. Accessed November 25 <http://meteonorm.com/>
- Morel, N. 2004. *Description of the LESO Building*. Swiss Federal Institute of Technology. Switzerland.
- SIA. 2006. *Condition d'utilisation standard pour l'énergie et les installations du bâtiment*. Swiss society of engineers and architects. Switzerland.
- UN. 2011. *World Urbanization Prospects: The 2011 Revision*. United Nations, Department of Economic and Social Affairs, Population Division. United States