



# ACADIA 2014 DESIGN AGENCY

USC School of Architecture, Los Angeles

Proceedings of the 34rd Annual Conference  
of the Association for Computer Aided Design in  
Architecture

Edited by David Gerber, Alvin Huang and Jose Sanchez

# SNAP-FIT JOINTS

CNC-FABRICATED, INTEGRATED MECHANICAL ATTACHMENT FOR STRUCTURAL WOOD PANELS

Christopher Robeller  
Paul Mayencourt  
Yves Weinand  
Swiss Federal Institute of  
Technology Lausanne EPFL

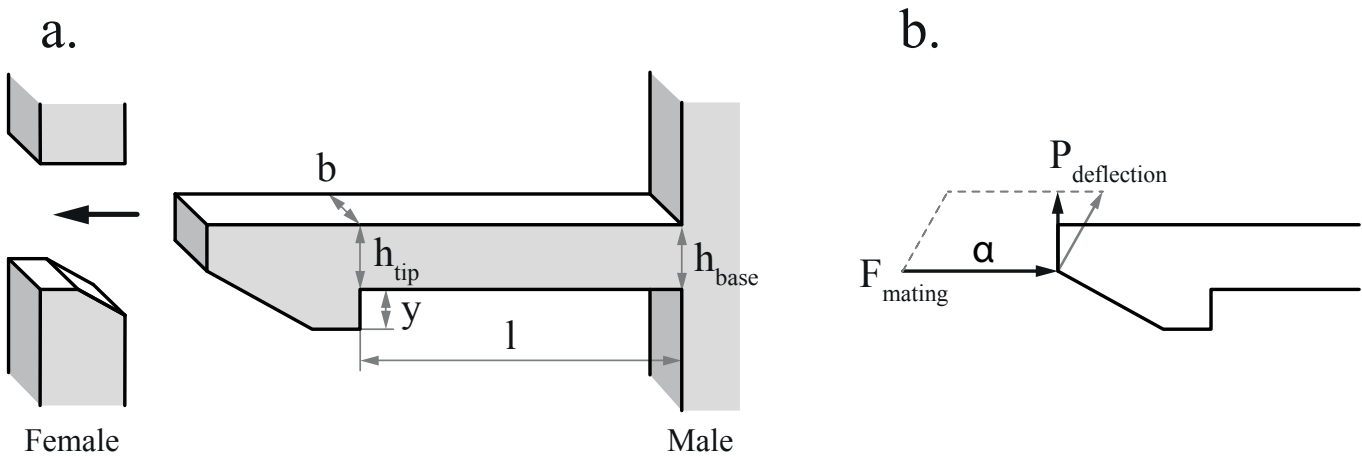

1 Basic Cantilever Hook Nomenclature: (a) Geometrical parameters of the two parts. (b) Mating force  $F_{mating}$  in relation to the insertion angle  $\alpha$  and the deflection force  $P_{deflection}$

## ABSTRACT

This paper describes the design and potential applications of CNC-fabricated *snap-fit joints* for *cross-laminated veneer lumber* panels (LVL). These joints are new to the building construction sector, but commonly used in other domains such as the automotive or consumer electronics industry. We explain our application of existing knowledge about the design and dimensioning of such joints, as well as several adaptations that we have made in order to optimize the connectors for the jointing of structural wood panels. This was necessary due to the materials and fabrication processes in timber construction, which are different from those in the sectors of origin of the *snap-fit joints*. We propose applications, including two case studies with physical prototypes:

1. A box girder prototype on which we introduce the combination of snap-fit joints with shear-resistant tab-and-slot joints and test the mechanical performance of the joints.
- 2: A double-layer arch prototype with non-orthogonal, 5-axis CNC-fabricated joints.

## INTRODUCTION

In 2010 the building sector was responsible for nearly a third (32 per cent) of global final energy use. The embodied energy in buildings can be significantly reduced with materials which require less energy in their production, such as wood products (IPPC 2013). Typical building certified spruce *laminated veneer lumber* (LVL) panels are made from more than 90 per cent renewable materials and store 450 g of carbon per kg. Following the combustion conditions provided by the manufacturer, these panels can be recycled into energy production.

Generally, due to its low weight-to-strength ratio, timber is an ideal material for the production of prefabricated building components, where ease-of-transport, handling and assembly have a great impact on the construction footprint, cost and timespan. In this context, LVL panels offer particular advantages: Compared to *cross-laminated timber* panels (CLT), thinner cross-sections are possible with the more homogenous and mechanically strong peeled-veneer laminate components, such as the *Kerto RIPA* rib or box elements (MetsäWood 2014).

In the context of shell and spatial structures, timber panels machine easily into irregular shapes, and prefabrication simplifies the use of advanced techniques and technology. However, while LVL panels offer numerous advantages for such constructions, design constraints result from limitations in the edgewise jointing of the thin panels. Geometrically simple, orthogonal components such as the *Kerto RIPA* elements can be prefabricated with glued butt joints. On site, metal plates or fasteners are used for the final assembly. Gluing is not possible due to a lack of constant conditions for the curing of the adhesive. For more complex timber panel assemblies, such as folded plate structures (Buri 2010), the assembly of large amounts of angular edgewise joints becomes very challenging with state-of-the-art metal fasteners. Previous studies have also demonstrated that the structural performance of such designs could be increased considerably through improved joints (Hahn 2009).

Inspiration for improvements can be taken from Integral mechanical attachment, the oldest known method of joining (Messler 2006). Rigid interlocks form one category of this general concept, including connections like mortise-and-tenon, dovetail or finger-joints, which were common handcrafted joining techniques in traditional carpentry and cabinetmaking. However, with industrialization and its proliferation of machine-tool-technology (Schindler 2009), these joints were widely replaced by mass-produced metal plate connectors and fasteners. Only recently, the increasing use of information-tool-technology in timber construction

companies and Application Programming Interfaces for the algorithmic generation, analysis of integrated joints, has caused a resurgence of integral mechanical attachment techniques.

First examples of integrated line-joints for wood panels have been demonstrated on the ICD//ITKE Research Pavilion 2011 (la Magna et al. 2013) and the Curved-folded CLT Pavilion (Robeller et al. 2014), as well as the recent ICD//ITKE LaGa Exhibition Hall (ICD//ITKE 2014). In these projects, form-fitting joints integrate locator features for the fast and precise positioning of elements, which enables and simplifies complex assemblies. Simultaneously, the joints participate in the load-bearing connection of the components through their connector features. Additional metal fasteners or adhesive bonding are necessary to receive forces and to retain elements in their remaining degrees of freedom.

A possible solution for the jointing of structural wood panels without additional fasteners or adhesive bonding may be found in *elastic interlocks*, another category of integral mechanical attachment techniques. So-called *snap-fit joints* provide an integrated locking feature to connect the parts. While *snap-fit joints* are a common attachment technique in the consumer electronics or automotive industry, possible applications for the jointing of timber panel structures have yet to be studied.

## CONCEPT

*Snap-fit joints* are widely used in the industry as a simple, economical and quick way of connecting two parts. The joints consist of one male and one female part. The temporary bending of the cantilever hook allows the fit of two pieces, using the material's elasticity property. After the joining operation, the pieces return to a stress-free state. The geometrical parameters of the parts define the force needed to assemble or disassemble it and the separable or inseparable characters of the joints. The joint is mainly designed according to the mechanical load during assembly and its corresponding assembly force (Figure 1).

## GENERAL JOINT DESIGN

Rudimentary design is provided by the snap-fit manufacturers such as BASF (BASF 2007) or Bayer (Bayer MaterialScience LLC 2000). Based on the assumption of the Euler-Bernoulli beam theory, the design variables for the joints are the following:

- Height of the cantilever beam  $h$ ,
- Length of the cantilever  $l$ ,
- Width of the cantilever  $b$ ,
- Undercut  $y$ .

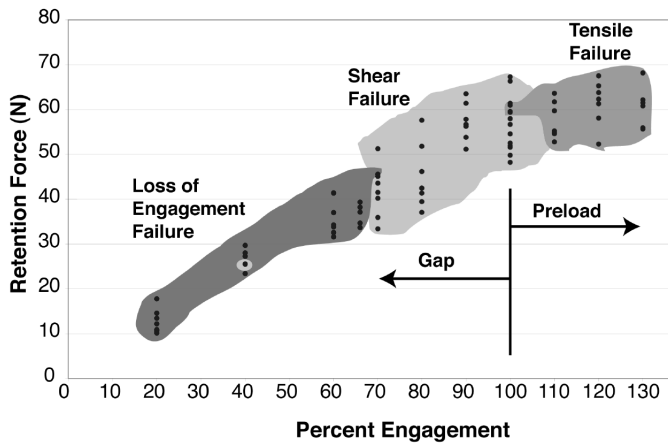

2 Retention Force Diagram (Courtesy of A. Luscher)

Given the maximal permissible strain of the material  $\epsilon$ , the maximal deflection for a cantilever with rectangular and constant cross section is:

$$y_{\max} = 0.67 (\epsilon l^2) / h_{\text{base}}$$

For a cantilever snap joint with decreasing height to one-half at the tip over the length the 0.67 factor becomes 1.09.

During the assembly, the deflection force  $P$  at the tip of the cantilever at  $y_{\max}$  is given by:

$$P_{\text{deflection}} = (bh^2/6) (E\epsilon/l)$$

Where  $E$  is the E-modulus of the material and  $b$  the width of cantilever. More information on the design of cantilever snap joint with other geometry such as trapezoid section can be found at (BASF 2007) or derived from the beam theory of a cantilever beam with point load at the tip (Figure 2).

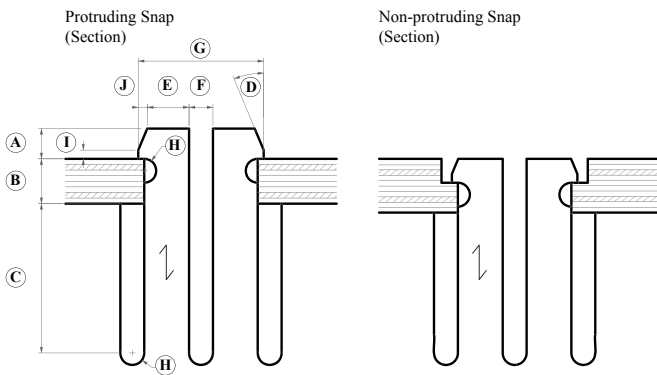

The force necessary to assemble the joint, called mating force, depends on the friction coefficient of the material  $\mu$ , the insertion angle and the deflection force. Both the deflection and friction force have to be overcome by the mating force:

$$F_{\text{mating}} = P [\mu + \tan(\alpha)] / [1 - \mu \tan(\alpha)]$$

The same equation can be used to determine the separation force of the joint where the insertion angle  $\alpha$  has to be replaced by the retention angle  $\beta$ . A value of  $90^\circ$  for the retention angle gives the maximal retention force.

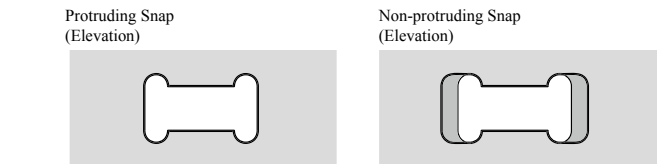

Furthermore, a study from Luscher (Luscher 1995) shows that the retention force not only depends on the retention angle but on the *Percentage of Engagement (PE)* as well. The engagement is the depth of insertion in the undercut of the mating part. A hook fully in contact with its mating part would have a *PE* of 100 per cent. The *PE* defines the failure mode and thus the maximal retention force. (Figure 1) shows that a *Percentage of Engagement* of 100 per cent or higher is preferable. Finally, the stress concentration at the root of the cantilever should be reduced by adding a fillet radius.

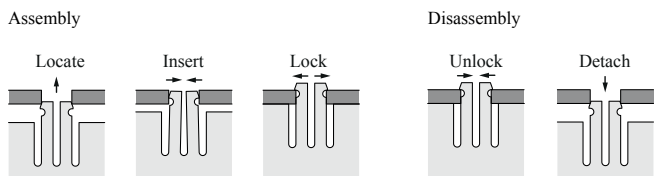

3 CNC fabricated Snap-fit Joint for LVL Panels - Protrusion (A), panel thickness (B), cantilever length (C), insertion angle (D), cantilever height (E), cantilever spacing (F), mating cutout (G), fillet radius (H), lateral pressure zone (I), undercut (J). Top right shows a version of the joint without hook protrusion. Bottom shows a schematic time-lapse assembly and disassembly.

## ADAPTATION TO FABRICATION AND MATERIALS IN TIMBER CONSTRUCTION

(Figure 2) shows our design for a CNC-fabricated snap-fit joint. For the production of our prototypes, we have used a MAKAMM7s 5-axis router equipped with a cemented carbide shank-type cutter with a radius of 6mm, operated at a feed rate of 6-8m per minute and a rotational speed of 17,000 revolutions per minute.



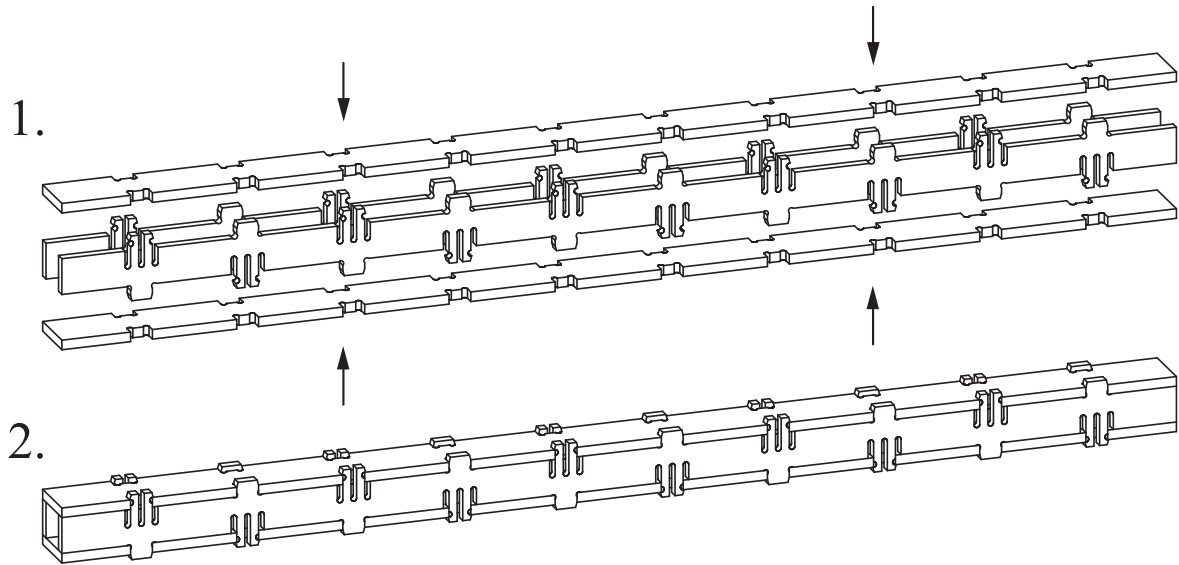

4 Box Girder Specimen for the Mechanical Analysis of Combined Snap-fit and Tab-and-slot Joints - A combination of the snap-fit joint with shear-resistant tab-and-slot joints allows for a mechanical behaviour equivalent to a screwed joint

The elasticity of the wood allows to design a cantilevering hook for the jointing of two panels of wood. For a given panel thickness  $t$  and an undercut  $y$  the cantilever length  $l$  and height  $h$  can be chosen to correspond to the material's limits:

Maximal permissible elastic strain in the bending direction.

Maximal compressive strength at the hook contact to avoid fiber crushing.

During the joining operation, the hook will be bent. This implies bending moment at the base of the cantilever and a deflection force against the mating panel. For a given undercut, the length and height of the cantilever have been chosen to limit the strain at the base in its elastic range and to avoid the crushing of the fibers at the tip of the hook and the top layer of the mating part, due to the deflection force. The undercut is the displacement constraint imposed to the hook during insertion. A smaller height gives a larger flexibility of the cantilever, smaller strain at the base ( $h$ ) and a smaller deflection force ( $h^2$ ). In case of the use of the retention resistance and an engagement of the hook higher than 100 per cent, the section of the cantilever have to be sized sufficiently for the disassembly tensile force.

## COMBINATION WITH TAB-AND-SLOT JOINTS

While *Snap-fit joints* can resist a certain retention force, they do not provide any shear resistance. In order to use this joint as a load-bearing connection for building components, we combine the snap-fit joint with prismatic tab-and-slot joints, which receive the majority of the forces. Generally, we consider the snap-fit-joint as a special type of tab-and-slot-joint, with an integrated retention feature. This combination of integrated joints allows us to achieve a mechanical behavior equivalent to a screwed joint. The specific shear-resistance of such a joint combination depends on the individual length and overall amount of the tabs. We have first tested this behavior on a simple box girder prototype (Figure 4).

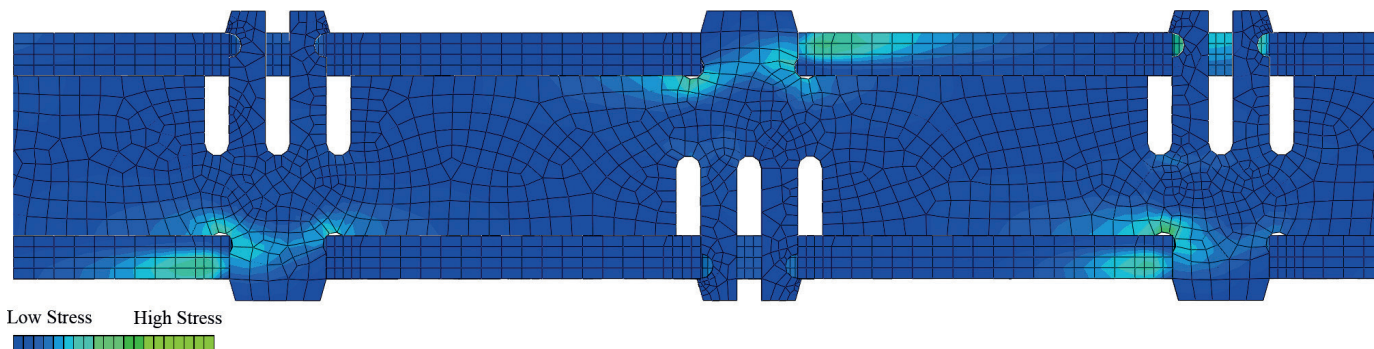

5 FEM Simulation of a 3-point Flexural Test with the Box Girder Specimen Geometry—the image shows compression on the tab-and-slot joints on side of the specimen. The FEM results were subsequently compared with a series of physical load tests.

## FABRICATION AND ASSEMBLY

The geometry of the joint is parameterized in a *Rhino3D* Python script. The geometry of the snap-fit joint is automatically generated based on the panel thickness and the before mentioned calculations. The *G-Code* for a *CNC* milling machine is also generated automatically at the same step.

The assembly of a snap-fit jointed beam is carried out by clipping the two webs to the bottom panel and finally connecting the top panel. This is done very quickly and no fixation is needed to get the precise geometry. The time of cutting is gained back with the simplicity of assembly of the beam. Moreover, the beam can be assembled and disassembled at any time. This means that the panels could be transported flat and then put together only when needed. The transportation volume for a beam with equivalent static height is greatly reduced.

## MECHANICAL PERFORMANCE

In order to evaluate the mechanical behavior of the *Snap-fit joints*, a set of three beams have been tested with a three point flexural test, loaded at mid-span. The results were validated with a Finite Element numerical model (Figure 5). The performance of the snap-fit beam is then compared to a beam with screwed connection. Finally, an optimized snap-fit beam is proposed with the conclusion of the analysis.

## PHYSICAL LOAD TESTS

The snap-fit beam specimens have been built with spruce Kerto-Q panels with a nominal thickness of 21 [mm]. The panels consist of seven laminated layers (|-| |-|), five of them in the main grain direction and two in the perpendicular direction (Technical Research Centre of Finland 2009). Kerto-Q has the advantage of being very dimensionally stable to humidity changes with good structural characteristics. The beam spans 2210.5 mm for a total length of the beam of 2431.6 mm. The size was constraint by the maximal dimension of the *CNC* milling machine 2.5 m. The displacements were both measured with Linear Variable Differential Transformer (LVDT) sensors on the top flange and with the stereo correlation technique on the bottom flange.

## NUMERICAL MODEL

Using the Finite Element Software Abaqus, the snap-fit joint beam was numerically simulated. The following material values were taken from the national technical approval certificate (VTT) of the panel manufacturer:

VARIABLES	VALUES FROM VTT FOR KERTO-Q 21 [MM]
Density	$\rho_{\text{mean}} = 510 [\text{kg}/\text{m}^3]$
$E_1$	$E_{0,\text{mean}} = 10,000 [\text{N}/\text{mm}^2]$
$E_2$	$E_{90,\text{edge}} = 2,400 [\text{N}/\text{mm}^2]$
$E_3$	$E_{90,\text{flat}} = 130 [\text{N}/\text{mm}^2]$
$\nu_{12}$	0.09
$\nu_{13}$	0.85
$\nu_{23}$	0.68
$G_{12}$	$G_{0,\text{edge,mean}} = 600 [\text{N}/\text{mm}^2]$
$G_{13}$	$G_{0,\text{flat,mean}} = 60 [\text{N}/\text{mm}^2]$
$G_{23}$	$G_{90,\text{flat,mean}} = 22 [\text{N}/\text{mm}^2]$

The Kerto-Q material was modeled as perfectly linear elastic. Linear brick 8-nodes elements with reduced integration (C3D8R) were used for the mesh. Attention was paid to refine the mesh at the contact zones. The contact is modeled with the general contact function of Abaqus. Its interaction property has two features: a tangential behavior defined by a friction coefficient  $\mu = 0.4$  (Technical Research Centre of Finland, 2009) and a normal behavior defined as 'hard contact.' Contact constraints are enforced for both with the penalty method. Separation after contact is allowed.

## RESULTS

This section presents the results of the experimental tests and the numerical model. The results of the test are consistent with the numerical results. A final deflection at mid-span of 35 [mm] was reached for the failure load of 6000N. The failure occurred in the panel. The numerical model gives a deflection of 32 mm for the same load. As we can see from the results in Abaqus (Figure 4), the snap-fit hook is not participating to the shear connection. Its stiffness is much lower than the tab connection as it was designed to be easily bent for the joining operation.

## OPTIMIZATION OF THE SNAP-FIT CONNECTION FOR THE BEAM

Looking at the result of the first snap-fit beam, the design of the beam could be improved or optimized by changing the hook geometry and the number of hooks. In the case of the beam, the snap-fit does not need to take any traction forces when the beam is loaded. The snap-fit is only necessary to

keep the pieces together during construction. This means that the hooks do not need to be designed for high traction forces but should only be able to retain the four panels from going apart. The snap-fit cantilever can then be slender designed to make it more flexible, which would reduce the risk of fiber crushing during insertion. Moreover, as the hook is not participating in the resistance of the shear connection, fewer snap-fits are needed and could be replaced by more tap joints to improve the shear capacity of the shear connection. Furthermore, it is not necessary to have the hook pointing in two directions. As it can be seen on the deformed shape of the beam in (Figure 4), the hooks pointing in the direction opposite of the shear stresses are losing contact as soon as the beam deforms and are then unnecessary. Less snap-fit hook will considerably reduce the cutting time with the CNC and improve the competitiveness of the technique over the glued or screwed connection. Finally, in order to have flat surfaces, the height of hooks and taps can be trimmed to the panel surface. The analysis of the optimized beam gives a deflection of 25 mm at mid-span for the same load of 6000N.

## COMPARISON WITH SCREWED CONNECTIONS

Metal fasteners such as screws allow for a fast and convenient assembly of wood components on site. Unlike adhesives, constant climatic conditions are not required for their assembly. However, for the edgewise jointing of structural wood panels with screws with a shaft diameter  $d$ , a lateral distance must be respected. For the Kerto Panels, the minimum distance is defined as  $5*d$ , while the minimum screw shaft diameter  $d$  is 6mm (Deutsches Institut für Bautechnik 2011). From this, we obtain a minimum lateral distance of 30 mm and a minimum panel thickness of 60 mm. Following these regulations, screwed edgewise joints cannot be used on thin LVL panels. Furthermore, large amounts of fasteners are necessary for load-bearing joints and additional locator features are necessary to improve precision and ease of assembly. The combination of integrated connectors presented in this paper supports loads not with additional fasteners but with the parametric geometry of the joints, which can automatically be optimized depending on the specific material characteristics and actual local load-bearing requirements. Elements can be transported to the construction site flat-packed and put together on site. This reduces the necessary transportation volume. Moreover, they can be quickly put together or disassembled if needed. Finally, the snap-fit connection is a mono-material connection, including advantages such as aesthetics, ease-of recycling or a homogenous thermal conductivity of the parts, which can reduce condensation and decay (Graubner and Wolfram 1986).

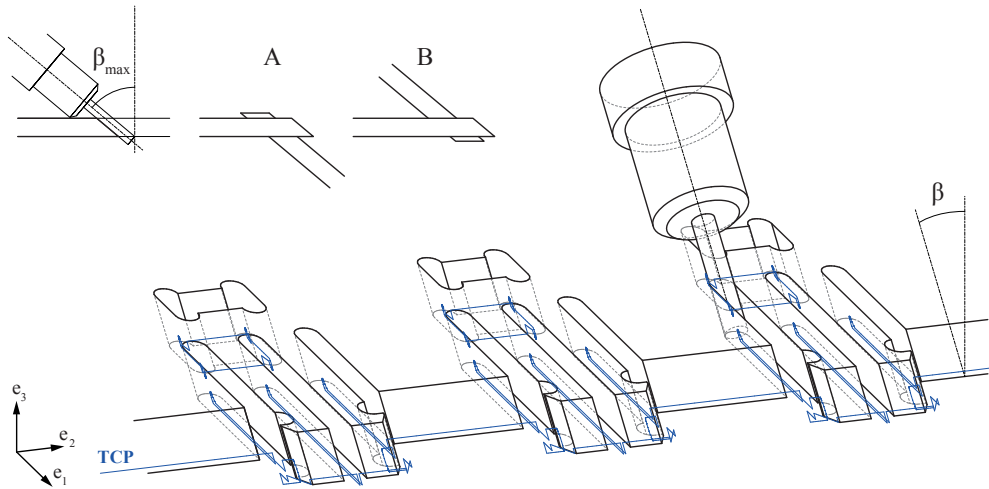

6 Side-cutting Fabrication of a Non-orthogonal Snap-fit Joint with a 5-axis CNC Router—The illustration at the top left shows the main fabrication constraint of the side-cutting technique, which is the maximum tool inclination  $\beta_{max}$ . It is determined by the geometry of the tool and the tool holder. From this angle, we obtain the most obtuse (A) and the most acute angle (B) for the non-orthogonal snap-fit joint. The blue line (TCP) shows the tool center point path, generated with our RhinoPython script. Note the automatic height compensation for inclined faces

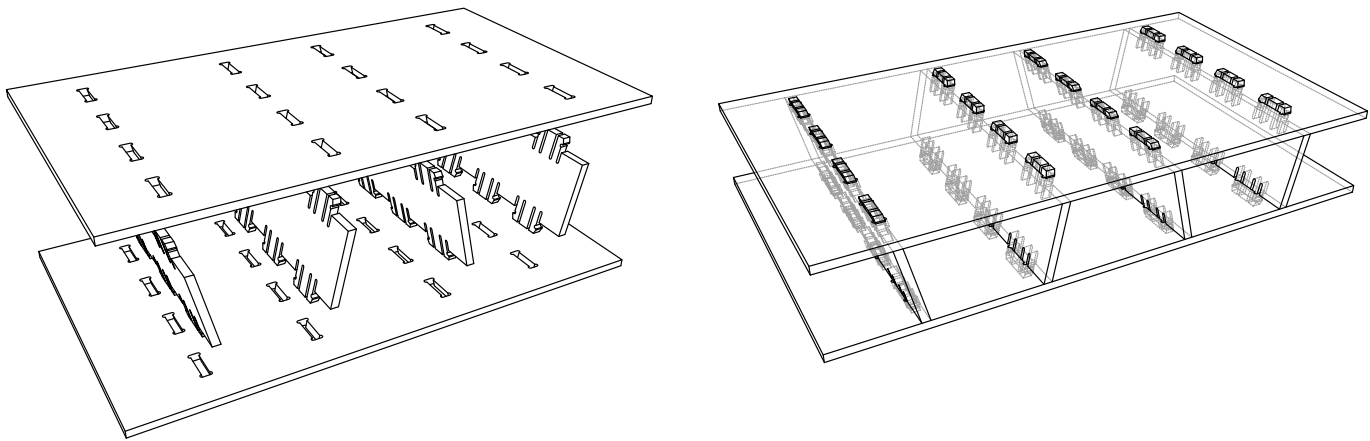

7 Sandwich Element with Inclined Vertical Connectors—The snap-fit joint allows for a simple, precise and quick assembly of non-orthogonal connections. There is no difference between the fabrication and assembly of a  $90^\circ$  joint and a  $110^\circ$  joint. This can be exploited for the assembly of corrugated sandwich components



Cassette

Shear block

Direct

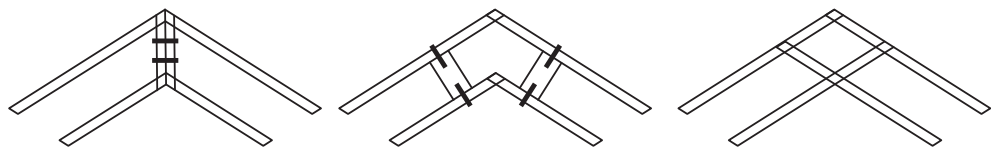

8 Prototype for a Snap-fit Jointed, Double-layered Corner ( $90^\circ$  and  $120^\circ$  fold)—built from 17mm plywood, 75mm spacing. Note the double-snap-fit element, which has a hook for the first layer and another hook for the second layer. The snap-fit joint in the middle is used as a spacer element. This technique can be used for structural improvement as well as for the fitting of (flocked) insulation materials



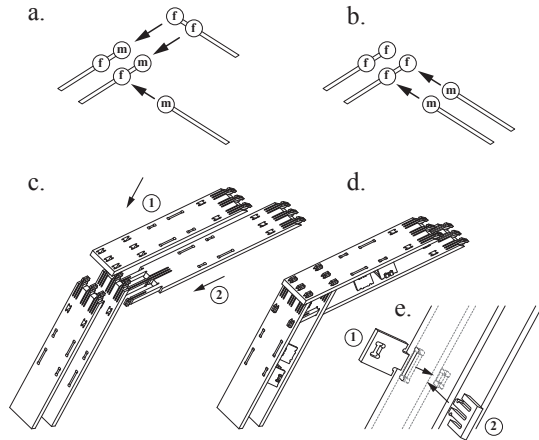

9 Assembly of Multiple Double-layer Components in one Direction—(a) and (b) show two possible male (m)/female (f) connector configurations and the resulting insertion directions of the panels. (a) requires spacer elements only on one interior panel, while (b) requires spacers on both interior panels. (c) and (d) show this method applied to an arch prototype. (e) shows additional snap-fitted shear block elements for this single-folded structure

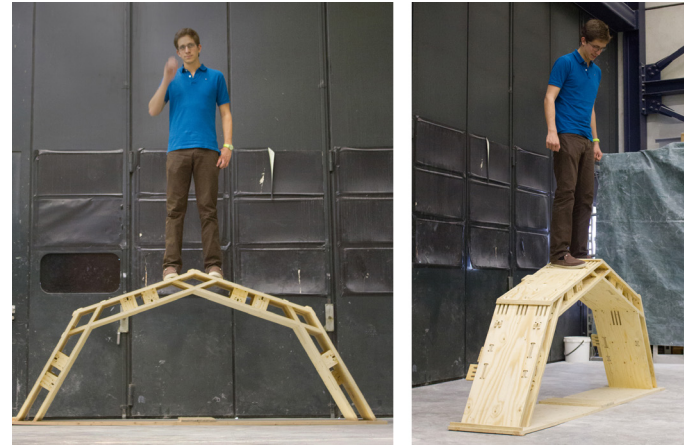

10 Physical Prototype of the Single-folded Double-layer Arch. - The prototype was built from Kerto-Q 21mm panels and spans over 2.5m

## APPLICATIONS AND FEATURES: 5-AXIS FABRICATION OF NON-ORTHOGONAL JOINTS

As one of the most important features, 5-axis cutting allows us to fabricate the snap-fit joint not only at 90°, but also for a fabrication-constrained range of non-orthogonal joints (Figure 6). Such angular joints can be used for the design of structurally efficient timber folded-plates.

## DOUBLE-LAYER STRUCTURES

As mentioned in our comparison with screwed joints, the combination of *snap-fit joints* and *tab-and-slot-joints* allows for the edge-wise jointing of thin LVL panels (for example Kerto-Q 21, 27, 32 mm). We can therefore, instead of a single layer of thick panels, design double-layer structures, where we achieve a large static height at a low self-weight and take advantage of the compressive and tensile strength of the panels at the top and bottom (Figure 7). Another advantage of such double-layer structures is the pre-fab-integration of insulation materials, which are protected from mechanical damage inside the components during transportation.

A particular structural advantage of the snap-fit and tab-and-slot joints on such double-layer assemblies is the possibility to establish a direct edgewise connection between all four layers of a fold (Figure 8). With longer snap-fit connectors, the interior panels of a fold can first cross through each other like a mortise-and-tenon joint, and then snap into the exterior layers above. The interior panels now double-lock the exterior panels in place, and the two additional line-joints per edge improve the overall stiffness and rigidity of the connection.

In an assembly with multiple components, additional elements can be added to a naked edge where both the exterior and the interior layer are fitted with either male or female connectors (Figure 9) and (Figure 10). This assembly constraint results from the fact that panels with *snap-fit joints* must be inserted along a vector that lies on the plane of the male part of the connection.

Finally, this assembly technique can also be applied to folded plate shells corrugated in two directions, allowing for the design of doubly-curved and free-form shell structures (Trautz, Martin et al. 2009; Falk, Andreas et al. 2011). In such structures, multiple edges must be jointed simultaneously, which has, depending on the chosen assembly technique (Figure 9a) or (Figure 9b), certain implications on the geometry of the folded plate shell (Figure 11). This prototype also demonstrates a possible combination of *snap-fit joints* with dovetail joints on the exterior panels of a fold. While performing similarly to the tab-and-slot joints, the dovetails do not require a protrusion on the panel with female connectors.

## CONCLUSIONS AND OUTLOOK

This first study on a snap-fit connection for structural wood panels clearly shows the potential of its application. Numerical parameterized geometry and CNC cutting technology enable the production of the joint. Few restrictions on the design need to be taken into account due to the wood's material properties. The behavior of the first application on a box-beam of the beam was satisfactory but showed that improvements of the connection are still possible.

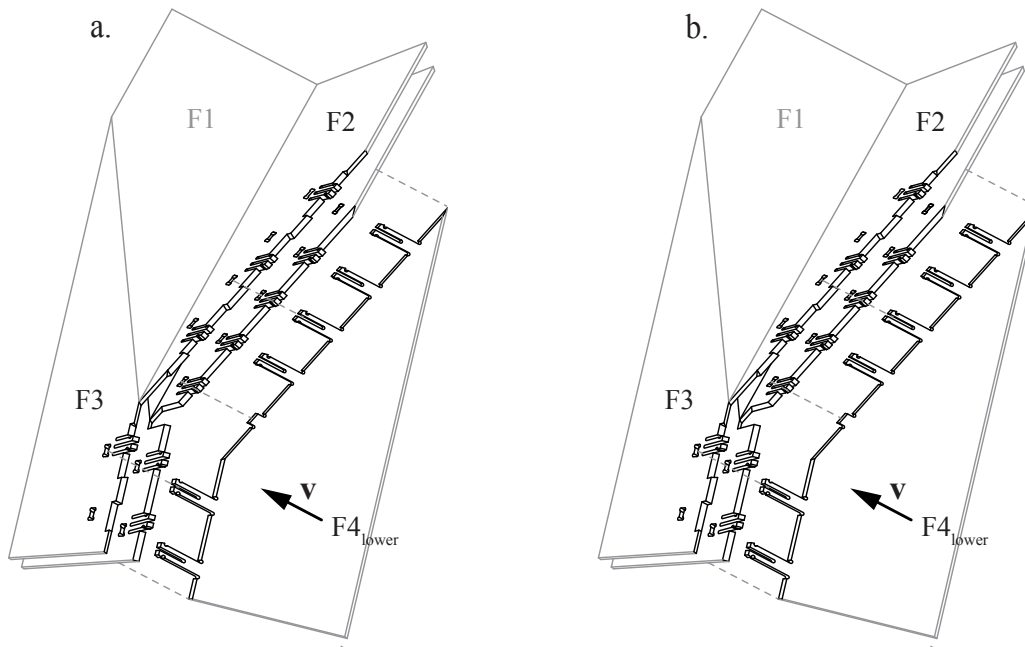

11 Assembly of a Double-layer Folded Plate Shell—(a.) Two edges of one panel ( $F4_{lower}$ ) simultaneously connect panels on two layers ( $F2_{lower} / F2_{upper}$ ) and ( $F3_{lower} / F3_{upper}$ ) via their four edges. The direction may be chosen within the plane of ( $F4$ ). (b) shows the insertion of the upper panel ( $F4_{upper}$ ) with female connectors. Here, the line of insertion must lie on all planes the panel will be attached to ( $F2$  and  $F3$ ). For only two edges, a solution will always be found at the intersection line of the two planes. This constraint does not apply to the technique shown in (Figure 9b). (c) shows the interior view of the double layer assembly. Joints will only be visible on the mountain folds. The drawings (d) and (e) show two possible fold patterns which are corrugated in two directions and their order of assembly. The illustrated Herringbone (d) and diamond patterns (e) require only a small deviation ( $\theta$ ) of the snap-fit joints' insertion direction from a line perpendicular to the edge to be jointed.

Finally, the construct-ability of more complex joint geometries was shown on the last part, taking advantage of the ability to join thin panels, which was used for the jointing of double-layer prototypes. The possibility of disassembling the parts at any time and transporting them unassembled opens a wide range of future applications such as temporary or modular structures.

## ACKNOWLEDGEMENTS

We would like to thank Andrea Stitic and Stéphane Nicolas Roche for the discussions and the conduction of the three-point flexural tests on the box beam specimen, as well as Jouni Hakkarainen and the Metsä Group for the supply of information and materials.

## REFERENCES

BASF The Chemical Company. 2007. Snap-fit Design Manual. BASF Corporation, Engineering Plastics, Florham Park, New Jersey.

Bayer MaterialScience LLC. 2000. Snap-fit Joints for Plastics—A Design Guide. Bayer Polycarbonates Business Unit, Pittsburgh, Pennsylvania.

Buri, Hans Ulrich. 2010. Origami—Folded Plate Structures. EPFL Doctoral Thesis No. 4714, École polytechnique fédérale de Lausanne.

Deutsches Institut für Bautechnik. 2011. Allgemeine bauaufsichtliche Zulassung Kerto-Q Z-9.1-100. Paragraph 4.2 and Attachment No 7, Table 5.

Falk, Andreas et al. 2011. "Form Exploration of Folded Plate Timber Structures based on Performance Criteria." Taller, Longer, Lighter: meeting growing demand with limited resources : IABSE-IASS Symposium 2011. London: Hemming Group Ltd., 2011.

Graubner, Wolfram. 1986. Holzverbindungen, Gegenüberstellung von Holzverbindungen Holz in Holz und mit Metallteilen. Deutsche Verlags-Anstalt Stuttgart, 19.

Hahn, Benjamin. 2009. Analyse und Beschreibung eines räumlichen Tragwerks aus Massivholzplatten. EPFL Master Thesis, École polytechnique fédérale de Lausanne.

IPCC. 2014. "Intergovernmental Panel on Climate Change 2014." <http://www.ipcc.ch/index.htm>.

Kollar, Lajos. 1993. "Some Problems of Static Analysis of Folded Plate Structures." *Periodica Polytechnica Ser. Civil Eng.* 37: 167–202.

La Magna, Riccardo et al. 2013. "From Nature to Fabrication: Biomimetic Design Principles for the Production of Complex Spatial Structures." *International Journal of Spatial Structures* 28 (1): 27–40.

Luscher, Anthony. 1995. An Investigation Into the Performance of Cantilever Hook-type Integral Attachment Features. Department of Mechanical Engineering, Rensselaer Polytechnic Institute.

ICD/ITKE. 2014. "LaGa Exhibition Hall." <http://icd.uni-stuttgart.de/?p=11173>.

Messler Jr., Robert W. (2006). *Integral Mechanical Attachment: A. Resurgence of the Oldest Method of Joining*. Butterworth Heinemann.

MetsäWood. 2014. "Kerto-ripa®." <http://www.metsawood.com/products>.

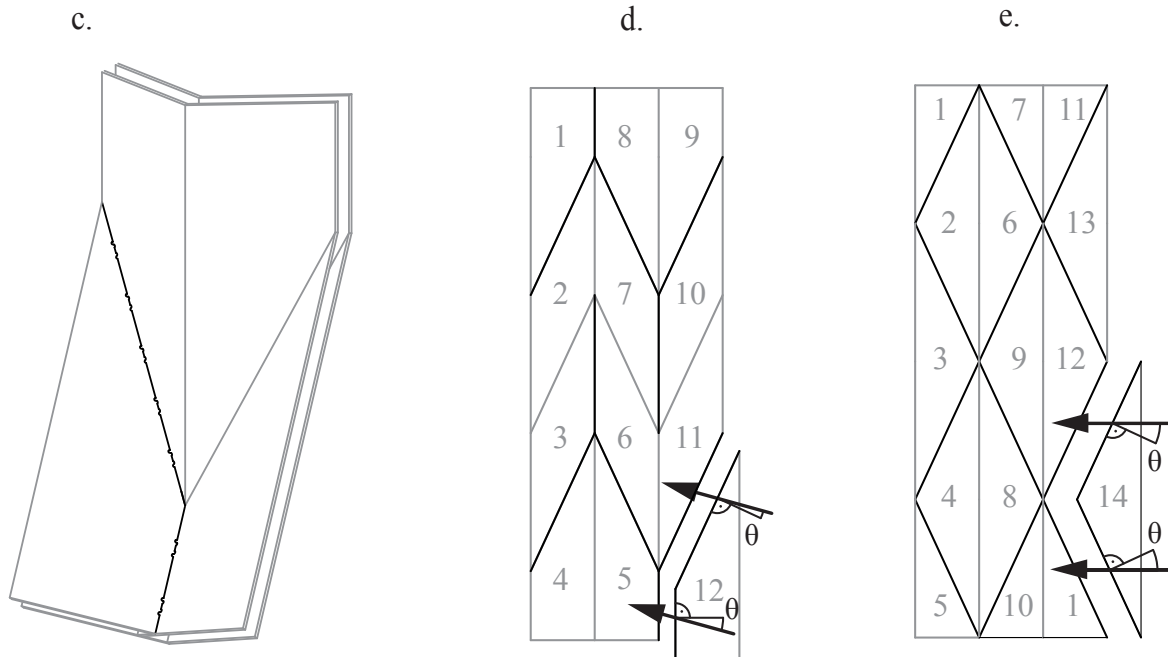

Robeller, Christopher et al. (2014). "Design and Fabrication of Robot-manufactured Joints for a Curved-folded Thin-shell Structure made from CLT." Robotic Fabrication in Architecture, Art and Design 2014.

Schindler, Christoph. 2009. "Ein architektonisches Periodisierungsmodell anhand fertigungstechnischer Kriterien, dargestellt am Beispiel des Holzbaus." Dissertation. ETH Nr. 1860.

Technical Research Center Finland. 2009. VTT Certificate No 184/03, revised.

Trautz, Martin et al. 2009. "The Application of Folded Plate Principles on Spatial Structures with Regular, Irregular and Free-form Geometries." Presented at the IASS—Evolution and Trends in Design, Analysis and Construction of Shell and Spatial Structures, Valencia.

## IMAGE CREDITS

Figure 1. With permission. From Luscher, A. (1995), *An Investigation of Cantilever Hook Type Integral Attachment Features*, Department of Mechanical Engineering, Rensselaer Polytechnic Institute

Figure 2-11. Image credit to Authors (2014).

**CHRISTOPHER ROBELLER** received his Professional Diploma in Architecture with Distinction from London Metropolitan University. He has worked as a Research Associate for the Institute for Computational Design (ICD) at the University of Stuttgart and is currently working as a PhD Candidate at the Timber Construction Laboratory IBOIS at the Swiss Federal Institute of Technology in Lausanne (EPFL). His research at the intersection of architecture, civil engineering and digital geometry processing is focused on the development of integrated, machine-fabricated jointing techniques for timber panel structures.

**PAUL MAYENCOURT** received his Bachelor Degree from the Swiss Federal Institute of Technology in Lausanne (EPFL) and his Master Degree in Structural and Geotechnical Engineering from the Swiss Federal Institute of Technology in Zurich in 2013 (ETHZ). He worked at the Timber Construction Laboratory IBOIS at EPFL as a research assistant and is currently working as a bridge engineer in Zurich.

**YVES WEINAND**, born 1963, Belgian, architect and engineer. After an architecture diploma at the Institut supérieur d'architecture Saint-Luc, Liège/Belgium, he worked as an architect in Helsinki, Finland; New York; and Brussels, Belgium. Civil engineering studies at the Swiss Federal Institute of Technology in Lausanne (EPFL) were followed by a PhD-thesis "Sichtbare Spannungen" at the RWTH Aachen University, Germany. Owner since 1996 of the Bureau d'Études Weinand, in Liège, Belgium, he was professor at the Institute of Structures at the Faculty of Architecture at Graz University of Technology in Austria, before joining the EPFL as a professor and head of the Timber Construction Laboratory IBOIS in 2004.