

# GRAVITY GRADIENT EARTH SENSOR EXPERIMENT ON REXUS 11

Kaustav Ghose<sup>(1)</sup>, Simon Dandavino<sup>(1)</sup>, Hervé Meyer<sup>(2)</sup>, Benoit Chamot<sup>(2)</sup>, Jean-François Labrecque-Piedboeuf<sup>(2)</sup>, Ioana Josan-Drinceanu<sup>(2)</sup>, Yann Voumard<sup>(2)</sup>, Muriel Richard<sup>(2)</sup>, Herbert Shea<sup>(1)</sup>, Jean-Noël Pittet<sup>(2)</sup>, Deborah Mueller<sup>(2)</sup>

<sup>(1)</sup> *Microsystems for Space Technologies Laboratory, EPFL, CP 526, rue Jaquet Droz 1, 2002 Neuchâtel Switzerland, herbert.shea@epfl.ch*

<sup>(2)</sup> *Swiss Space Center, EPFL, Switzerland, ELD-013 Station 11, 1015 Lausanne, Switzerland, Muriel.richard@epfl.ch*

## ABSTRACT

This experiment is the first test of the concept for a novel attitude determination sensor in freefall, that utilizes the Earth's gravity gradient as a reference. Current sensors require multiple optical heads with access on all faces of a satellite that might point towards the Earth [1]. Earth sensors determine the Earth vector by sensing the position of the Earth's horizon, detecting the Earth's IR emission against the background of space [2]. The gravity-gradient based approach does not require optical access for the sensor, and one single, compact unit can be located anywhere inside the satellite, and provide complete  $4\pi$  steradian field of view. The sensor principle is based on the use of a Micro Electro Mechanical System (MEMS) device that can measure the Gravity Gradient Torque (GGT) [3]. We describe the design of the experiment to test the MEMS GGT sensor on a REXUS flight and present the results obtained.

## 1. INTRODUCTION

The Microsystems for Space Technologies Laboratory (LMTS) of the EPFL has been developing a novel Earth Sensor that does not use any optics. The principle is based on the use of a MEMS (Micro Electro Mechanical System) device that can measure the Gravity Gradient Vector, which always points to the centre of the Earth. This is accomplished by measuring the torque, in free-fall conditions, due to the gravity gradient on an elongated proof mass. The objective is to measure the rotation of a silicon proof mass under free-fall conditions due to gravity gradient torque, and from the data, determine the accuracy of the attitude measurement for a Low Earth Orbit (LEO) satellite.

The gravity gradient torque (GGT) has been used to stabilize small satellites after launch, but never as an attitude determination scheme. Instead of the current Earth sensing methods that determine the Earth vector by sensing the Earth's IR emission, we are investigating a much lighter and more compact MEMS-based solution. Current Earth sensors use multiple telescopes and cameras. In the event that a

satellite starts to tumble, existing Earth sensors that use optical sensing are severely limited in their ability to reacquire the attitude due to the limited field of view of the instruments. Also, due to this limited field of view, multiple Earth sensor units need to be placed on all faces of the satellite to ensure  $4\pi$  steradian coverage. Because of the optical sensing principle of existing Earth sensors, constraints are imposed on the positioning of solar panels and antennas so that they do not block the field of view of optical sensors.

The MEMS-based approach does not require optical access, and thus one single, compact unit located anywhere inside the satellite provides full  $4\pi$  steradian field of view.

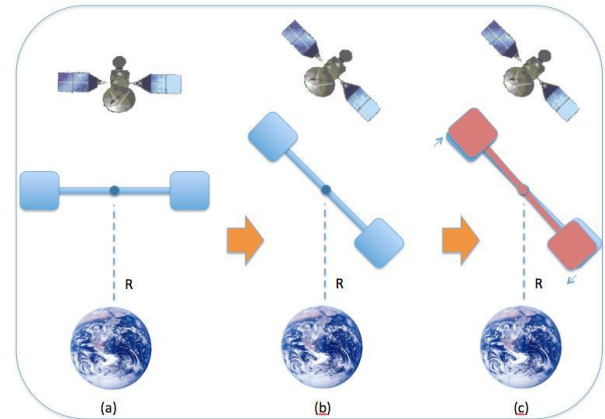

Figure 1. Diagram showing effect of the gravity gradient on an elongated proof mass. (a) the proof mass inside the satellite is perpendicular to the Earth. Both sides of the mass being the same distance from the Earth, there is no detectable effect. If the satellite rotates by a given amount (b), the mass inside also rotates. Since now one side is closer to the Earth and sees more gravity (c), the GGT will produce a displacement

Fig. 1 shows a schematic representation of a MEMS sensor. The chips have a proof mass suspended by springs from a frame. The frame is attached to the satellite body. In free fall, the proof mass is displaced in the order of a nanometer due to GGT. This displacement is dependent on the angle the proof mass

makes with the Earth. Therefore, by measuring the displacement the angle can be determined. A detailed analysis, design, fabrication of the MEMS chip is given in [3]. On Earth the GGT cannot be measured directly since the magnitude of gravity is many orders greater, and a period in free-fall is necessary to be able to test whether the sensor is able to measure GGT.

This is an inertial sensor, so any external inertial forces will produce an error in the measurement of displacement due to GGT. To estimate and eventually subtract these errors we need to measure the inertial environment that the experiment is in. For this purpose, we fly an Inertial Measurement Unit (IMU) with the MEMS, and record its output along with that of the MEMS. Redundancy is implemented in the MEMS and IMUs that forms the experiment. The data is stored on board, and we also utilize the REXUS telemetry downlink to have backup. The power supply for our experiment comes from the REXUS service module (RXSM). This experiment does not aim at proving a complete attitude determination system; just to test the MEMS Earth sensors in operating conditions that cannot be achieved in a laboratory on Earth.

## 2. EXPERIMENT DESCRIPTION

The main purpose of the experiment is to gather data from four MEMS chips that are sensitive to GGT. The chips have a proof mass and spring. The proof mass is displaced depending on the GGT on it, which depends on the angle the proof mass makes to the Earth's surface. This displacement is measured by means of recording a change in differential capacitance, as measured on electrodes at opposite ends of the elongated proof mass.

The experiment is divided by functions into three electronic circuit boards (Fig. 2):

- Main board for interfacing with the RXSM, and provide power supply, telecommands and telemetry for the experiment. It also processes the Start Of Experiment (SOE) and Lift Off signals from the RXSM. Two science boards are connected to the main board.
- Science board for data acquisition from the MEMS and IMU, and for onboard data storage. Two MEMS boards connected to each science board.
- MEMS board with one MEMS chip each. This provides mechanical support for the MEMS chip, contains the electronics for recording the differential capacitance and temperature values from the MEMS chip, and also has a heater to prevent moisture condensing on the MEMS at low temperatures. There are a total of four MEMS boards.

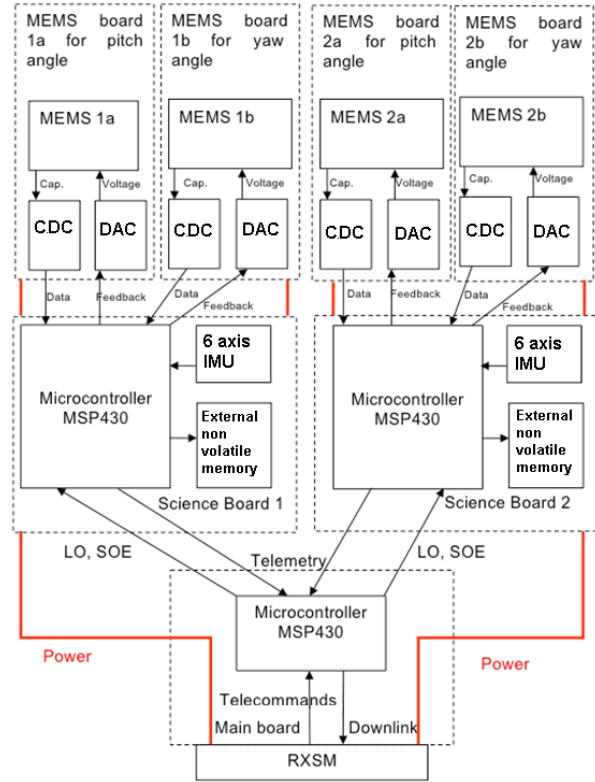

Figure 2. Diagram of GGES experiment setup

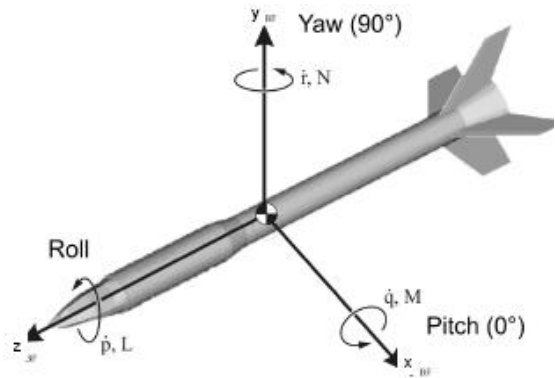

Figure 3. REXUS body frame coordinate system. [4]

With respect to the body frame coordinate system of REXUS (Fig. 3), the MEMS chips are arranged to measure the pitch and yaw angles. To ensure that there is a measurable signal irrespective of the angle at which the rocket ends up at after launch, and for some redundancy, for each angle a second MEMS chip, oriented in a plane 45 degrees is used. There are two sets of MEMS chips, one set to measure yaw, the other to measure pitch. One chip from each set is connected to a single science board for redundancy. If one science board stops working, yaw and pitch measurements should still be possible on the other science board.

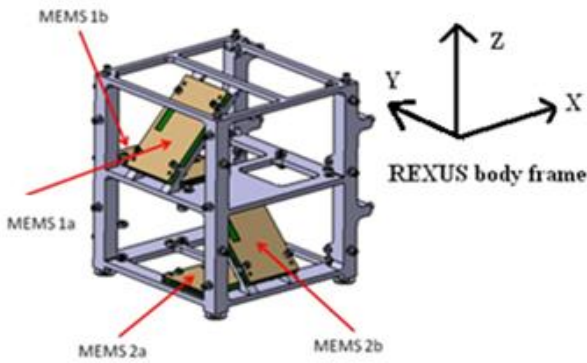

Figure 4. Mounting of the MEMS boards

To measure pitch, the Earth sensor is placed in the XY plane such that the longitudinal axis of its elongated mass is parallel to the Y axis (MEMS 2a). In such an orientation, due to GGT the proof mass will pivot around the X axis and the displacement will be proportional to the pitch angle. During the flight it is possible that the payload will not change its orientation much, even after separating from the booster. If the Z axis of the rocket stays close to the Earth's surface normal, then it is possible that the displacement due to GGT measured by the MEMS ES will be within its error limits. To obtain an Earth vector signal in this case, a second MEMS ES (MEMS 1b) is oriented at 45 degrees to MEMS 1a. The longitudinal axis of its elongated mass is in the YZ plane, but at an angle of 45 degrees to the Y axis. This will ensure that in case the payload is oriented with the Z axis almost vertical, the second MEMS sensor will have the largest possible displacement due to GGT.

Similarly, to measure yaw, the Earth sensor is placed in the XY plane such that the longitudinal axis of its elongated mass is parallel to the X axis (MEMS 2a). In such an orientation, due to GGT it will pivot around the Y axis and the displacement will be proportional to the yaw angle. A second ES (MEMS 2b) is oriented with the longitudinal axis of its elongated mass is in the XZ plane, but at an angle of 45 degrees to the X axis, to ensure a displacement due to GGT for the yaw axis.

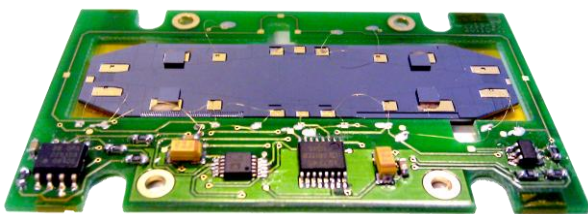

Figure 5. MEMS board showing the silicon micro-electro-mechanical sensor, and electronics to measure the displacement of the proof mass.

### 3. RESULTS

The GGES experiment has four MEMS sensors onboard. The sensors consist of a silicon proof mass sensitive to GGT, suspended from compliant springs. The dimensions of the spring can be modified in order to obtain springs of different compliance, resulting in different fundamental mechanical eigenfrequency.

On the GGES experiment, there are a total of four sensors, with frequencies of 3 Hz (1A), 8.5 Hz (2B), and 20 Hz (1B, 2A) as shown in Fig. 6.

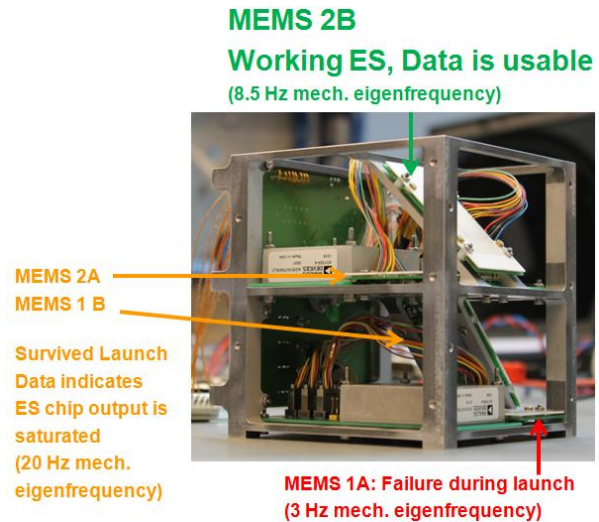

Figure 6. Performance of the various MEMS Sensors onboard the GGES experiment

- MEMS 1A - Failure at launch, the data indicates mechanical failure of the wirebonds, or the silicon springs. The wirebonds connect the silicon MEMS to the electronics.
- MEMS 1B and 2A – Data are recorded from these sensors during the entire flight. However the output is saturated, indicating that the effect of stress on the MEMS chip during launch results in the silicon proof mass getting stuck.
- MEMS 2B – Data recorded from this sensor indicate that it functioned nominally during the flight.

Fig. 7 shows the capacitance change recorded from this sensor along with IMU data for acceleration in rocket Z axis and rotation around rocket Z axis. A strong correlation is observed between the displacement of the proof mass and flight timeline events such as motor burnout, payload despin and start of re-entry as recorded by the IMU. MEMS 2B is a functioning inertial sensor.

The MEMS sensor records useful data only when the REXUS payload is in freefall. The IMU data is used to determine when the payload enters freefall.

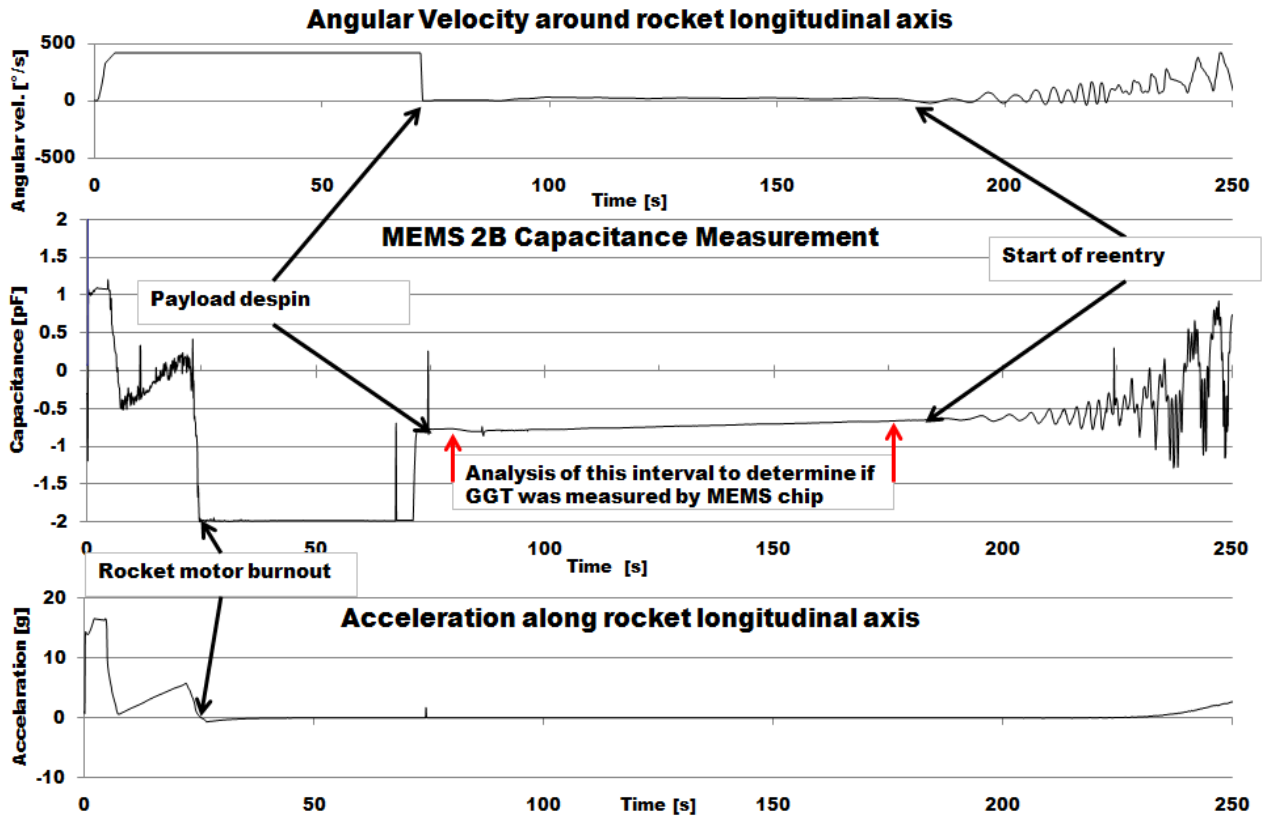

Figure 7. MEMS 2B displacement with IMU data from liftoff (LO) to LO+250 s

From Fig. 7, it is observed that motor burnout happens at ~25 seconds after LO, and the payload is despun at LO+ ~73s. During the operation of the motor and payload spin the change of capacitance of the MEMS sensor due to these external inertial forces is also indicated in Fig. 7. Events on other REXUS 11 experiments (Telescope boom deployment, ADIOS imbalance generator) that cause an inertial perturbation on the payload are reflected in the data from the MEMS. Due to this, only data from LO+100s to LO+180s are considered. MEMS 2B is oriented such

that any GGT sensed on it is due to the payload rotating about its Y (yaw) axis, as defined in the REXUS body frame reference. The IMU data for rotation about the yaw axis, measured with respect to the pitch axis (X axis of body frame) is used to determine the orientation of MEMS 2B during the freefall phase. The point at which the payload is despun is used as a reference to start computing the orientation of the payload, and therefore MEMS 2B during freefall.

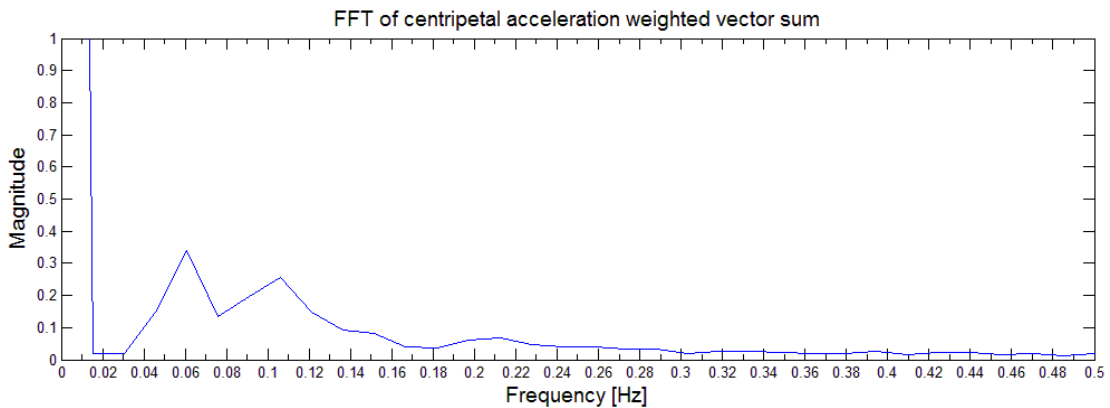

Figure 8. FFT of centripetal acceleration along REXUS roll axis during freefall; Peaks are observed at ~0.07 and ~0.11 Hz

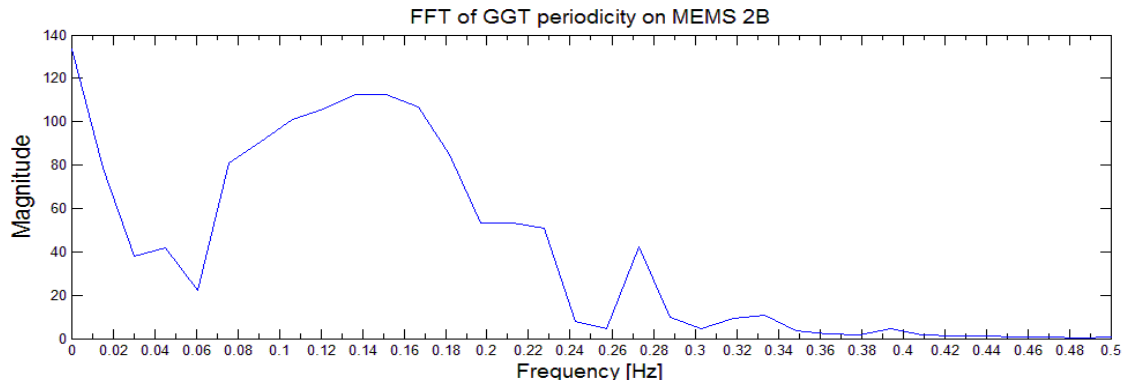

Figure 9. FFT of GGT periodicity; Peak at  $\sim 0.14$  Hz

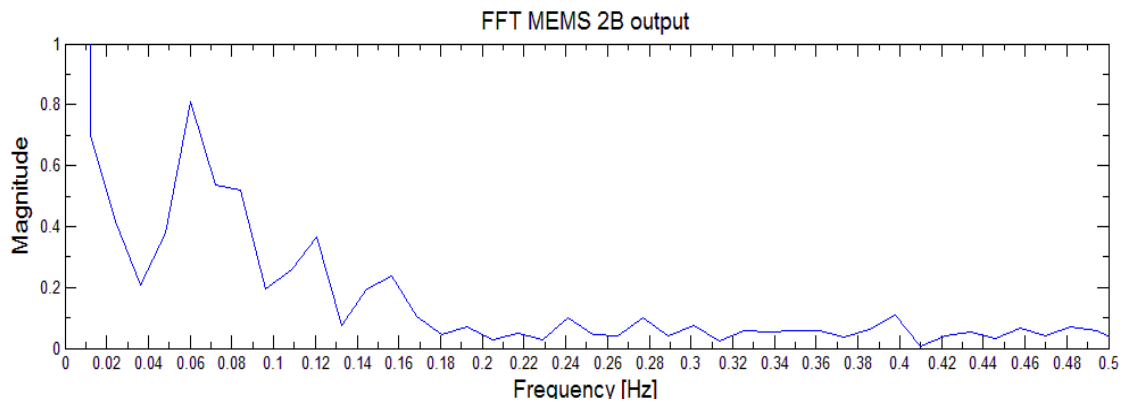

Figure 10. FFT of temperature drift compensated MEMS output from LO+100s to LO+180s; peaks at  $\sim 0.7$  Hz,  $\sim 0.11$  Hz and  $\sim 0.14$  Hz

Fig. 8 shows the FFT of the magnitude of the centripetal acceleration as measured by the IMU from LO+100 s to LO+180 S, weighted by impact on MEMS 2B. Peaks are observed at  $\sim 0.07$  and  $\sim 0.11$  Hz. Fig. 9 shows the results of FFT on the GGT period of MEMS 2B as extrapolated from the angular displacement measured by the IMU on the pitch axis. Any GGT measured by the MEMS will have the same frequency distribution. The peak of the FFT is observed at  $\sim 0.14$  Hz. Fig. 10 shows the FFT of the capacitance measured corresponding to displacement of the proof mass of MEMS 2B. There are peaks at  $\sim 0.7$  Hz,  $\sim 0.11$  Hz and  $\sim 0.14$  Hz. This displacement can be due to centripetal force or GGT. The peaks observed at  $\sim 0.07$  Hz and  $\sim 0.11$  Hz in the MEMS 2B FFT correspond to the peaks observed for centripetal force along the roll and pitch axes.

The peak observed at  $\sim 0.14$  Hz in the MEMS 2B FFT corresponds to the FFT of the GGT periodicity, and shows that GGT was measured by the MEMS chip during the REXUS ballistic phase post payload despin, and before re-entry.

#### 4. CONCLUSION

The objectives of the GGES experiment were:

- Record the displacement of a MEMS proof mass due to GGT in free fall.

- Record the external rotational forces acting on the experiment.

- Record the external translational forces acting on the experiment.

- Post flight, from the displacement data gained, subtract errors estimated from the inertial environment information recorded during the flight and verify that the displacement of the Earth sensor corresponds to the GGT. Estimate the accuracy of the MEMS in measuring the Earth vector.

Even though only one out of four MEMS sensors functioned during flight, the first three objectives are met.

The frequency domain analysis shown in Figs.8-10 indicates that GGT was measured by the MEMS during flight. It also indicates that GGT measurement is possible using such a MEMS device even in an environment where there is significant tumble of the payload.

Due to the low signal to noise ratio of the GGT signal, a time domain analysis is not performed. Additionally an accurate reconstruction of the 6 axis motion of the MEMS based on 6 axis information provided by the IMU cannot be done accurately, due to the physical separation of the center of mass of the MEMS and the IMU reference point, and unknown distance with respect payload center of rotation. Hence it was not possible to estimate the accuracy with which the MEMS measures the yaw angle with respect to the pitch axis. For future work towards developing an Earth sensor based on measuring the gravity gradient, an improvement in the signal to noise ratio of the MEMS readout is necessary.

## 5. REFERENCES

- [1] J.R. Wertz, W.J. Larson, Space Mission Analysis and Design, Kluwer Academic Publishers, Dordrecht, 1999
- [2] Lunde B.K., "A Reliable Earth Sensor For Attitude Sensing", IEEE Transactions on Aerospace and Navigational Electronics, Oct. 1963, Issue: 0 page(s): 3.6.4-1 - 3.6.4-6
- [3] K. Ghose, "MEMS Inertial Sensor to measure the Gravity Gradient Torque in Orbit" Ph.D. dissertation, Institute of Microengineering, EPFL, Lausanne, Switzerland, 2012
- [4] EuroLaunch REXUS User Manual (2010)