

MATHEMATISCHES FORSCHUNGSINSTITUT OBERWOLFACH

Report No. 28/2011

DOI: 10.4171/OWR/2011/28

Schnelle Löser für Partielle Differentialgleichungen

Organised by
Randolph E. Bank, La Jolla
Wolfgang Hackbusch, Leipzig
Gabriel Wittum, Frankfurt

May 22nd – May 28th, 2011

ABSTRACT. The workshop *Schnelle Löser für partielle Differentialgleichungen*, organised by Randolph E. Bank (La Jolla), Wolfgang Hackbusch (Leipzig), and Gabriel Wittum (Frankfurt am Main), was held May 22nd – May 28th, 2011. This meeting was well attended by 54 participants with broad geographic representation from 7 countries and 3 continents. This workshop was a nice blend of researchers with various backgrounds.

Mathematics Subject Classification (2000): 65N55, 65M55, 65M60, 65N30, 65N50, 65F10, 65F50, 65H10, 65K10.

Introduction by the Organisers

The conference was organized by Randolph E. Bank, UCSD, La Jolla, Wolfgang Hackbusch, MPI Leipzig, and Gabriel Wittum, University of Frankfurt. This was the fifth one in a series of conferences on fast solvers held at Oberwolfach since 1999. The idea of these workshops is to bring together experts from the different thriving areas of solvers and offer a platform for scientific exchange and progress.

The field of solvers for the algebraic systems arising from the discretization of partial differential equations has developed to a major area of numerical mathematics and scientific computing. Solvers are the essential part of simulation codes for problems from science and technology, in many cases determining the complexity of the whole simulation. By virtue of that, the choice of the solver can decide on the reliability of a simulation and if it can be done at all. Thus, solvers are a substantial mathematical component of most simulation tools and a major contribution of mathematics to quite a lot of applied disciplines. This has increased

the interest in mathematics of colleagues from the applied sciences over the last decade substantially.

Major areas of solvers represented at the workshop are: Multigrid methods, H-matrices, domain decomposition methods, and conjugate gradient methods and their scalable parallelization on huge numbers of cores. Often these methods are combined, e.g. conjugate gradient like methods are used as accelerator for multigrid. Besides that, several talks were given on other aspects of solving partial differential equations, such as discretization schemes and the algebraic properties of the resulting stiffness matrices, overall solution strategies, and application areas where solving plays a crucial role. The question of the right solver for critical application problems is still open, but new approaches have been developed in recent years. New light is shed on the solver question by the recent change of paradigm in computer architecture. The modern multicore processors with additional strong GPU and MIC accelerators pose a new and serious challenge for the development of fast solvers. A total of ... presentations gave a nice overview over the current research, open problems and new developments. Intense discussions provided the opportunity to go into details of novel algorithms and approaches. In multigrid methods, a lot of research is going in the direction of developing robust methods for special applications. This is a challenging topic requiring mathematical expertise as well as understanding of the model and the application process itself. Another major topic is Algebraic Multigrid. AMG methods are already wide spread in several applied communities. However, a lot of open problems remains and the final algorithm is not yet in sight. Several talks also were related to performance issues of multigrid on certain computer architectures such as super scalar or parallel computers. Multigrid research is thriving more than ever. Another bunch of talks were about domain decomposition methods. These methods are of particular interest for multiphysics problems and parallelization issues. Several new developments have been reported and discussed, giving interesting future perspectives. Often techniques from domain decomposition analysis can be used to analyze other methods e.g. multigrid. A novel technique useful together with domain decomposition and multigrid, but can also stand on its own, are hierarchical matrices (H-matrices). Here, several talks have shown the impressive level of development these methods already have obtained. Tensor representation and solving the corresponding equations was discussed in several talks at the conference. This novel class of numerical reduction methods got a lot of attention. It comes from solving high dimensional problems, but can be used to reduce also low dimensional ones. Further talks have discussed solver techniques for application problems as well as other problem areas like optimization. In total, the workshop was very successful in bringing together international-level experts from different areas and disciplines. Meanwhile, the Oberwolfach workshop on *Schnelle Löser für partielle Differentialgleichungen* is established as major event in the solver community and a mainstay for novel developments.

Workshop: Schnelle Löser für Partielle Differentialgleichungen**Table of Contents**

Volker Mehrmann (joint with C. Carstensen, J. Gedicke, A. Miedlar, C. Schröder)	
<i>Multi-way adaptive methods for the solution of non-selfadjoint PDE eigenvalue problems</i>	5
Christian Wieners (joint with Daniel Maurer, Alexander Buloviyatov, and Jiping Xin)	
<i>Parallel solution methods for Maxwell's eigenvalue problem</i>	9
Mary Wheeler (joint with Guangri Xue, and Ivan Yotov)	
<i>Accurate Cell-Centered Discretizations for Modeling Multiphase Flow in Porous Media on General Hexahedral and Simplicial Grids</i>	10
Steffen Börm	
<i>\mathcal{H}^2-Matrix Galerkin Approximation</i>	11
Craig C. Douglas (joint with Victor Calo, Nathan Collier, Hyoseop Lee)	
<i>Isogeometric Multigrid</i>	12
Susanne C. Brenner (joint with Andrew T. Barker, Eun-Hee Park, Li-yeng Sung, Kening Wang)	
<i>DD for DG</i>	13
Ralf Hiptmair (joint with Shipeng Mao)	
<i>Stable Multilevel Splittings of Boundary Element Spaces</i>	15
Alfio Quarteroni (joint with Andrea Manzoni, Gianluigi Rozza)	
<i>Model order reduction by reduced basis methods and free-form deformations for shape optimization</i>	19
Jeff Borggaard (joint with Imran Akhtar, Alexander Hay, Traian Iliescu, and Zhu Wang)	
<i>Reduced-Order Models of Fluids for Simulation, Design and Control</i> ...	22
Rob Stevenson (joint with Alan Demlow)	
<i>Convergence and quasi-optimality of an adaptive finite element method for controlling L_2 errors</i>	26
Jeffrey S. Owall (joint with Michael Holst, Ryan Szykowski)	
<i>Constructing and Analyzing Non-Standard Error Estimators of Hierarchical-Type</i>	29
Kees Vuik (joint with Jok Tang, Scott MacLachlan, Reinhard Nabben)	
<i>A Comparison of Two-Level Preconditioners based on Multigrid and Deflation</i>	32

Gundolf Haase (joint with Manfred Liebmann, Aurel Neic)	
<i>GPU acceleration of PDE solvers</i>	35
Sabine Le Borne (joint with Jeff Ovall)	
<i>One-step hierarchical preconditioners for higher-order FEM</i>	36
Zeyao Mo	
<i>New Parallel Paradigms for Scientific Computing</i>	38
Robert Falgout	
<i>Towards Multigrid on Millions of Cores</i>	40
Michael Holst	
<i>The Einstein Constraint Equations, Adaptive Methods for Geometric PDE, and Finite Element Exterior Calculus</i>	40
Arnold Reusken	
<i>Nitsche's method for a transport problem in two-phase incompressible flows</i>	41
Lars Grasedyck (joint with Jonas Ballani, Melanie Kluge)	
<i>Hierarchical Tensor Methods for PDEs with Stochastic Parameters</i>	45
Boris N. Khoromskij	
<i>Quantized TT approximation for fast solution of high-dimensional PDEs</i>	45
Wolfgang Hackbusch	
<i>Convolution of \mathbb{R}^n-vectors in $O(\log(n))$</i>	46
Alfio Grillo (joint with Michael Lampe, Dmitriy Logashenko, Sebastian Reiter, Sabine Stichel, Gabriel Wittum)	
<i>Models and Simulations of Variable-Density Flow</i>	48
Arne Nägel (joint with Gabriel Wittum)	
<i>Algebraic Multigrid for Density Driven Flow in Porous Media</i>	49
Ulrich Langer (joint with Michael Kolmbauer)	
<i>A robust preconditioned MinRes solver for distributed time-periodic eddy current optimal control problems</i>	51
Volker Schulz (joint with Nicolas Gauger, Stephan Schmidt, Caslav Ilic)	
<i>Fast solution of PDE constrained shape optimization problems</i>	54
Barbara Wohlmuth (joint with Markus Melenk, Christian Wieners)	
<i>Beyond classical saddle point theory</i>	54
Olof B. Widlund (joint with Clark R. Dohrmann)	
<i>Advances in Domain Decomposition Algorithms for $H(\text{curl})$ Problems</i> ..	55

Abstracts

Multi-way adaptive methods for the solution of non-selfadjoint PDE eigenvalue problems

VOLKER MEHRMANN

(joint work with C. Carstensen, J. Gedicke, A. Miedlar, C. Schröder)

The numerical solution of nonlinear PDE eigenvalue problems arises e.g. in the analysis, simulation and optimization of acoustic fields. There are several major challenges in current industrial problems and current methods. The analysis of these challenges leads to the conclusion that new adaptive algorithms and error estimates for eigenvalue problems associated with non-selfadjoint partial differential operators are needed. In this talk the basis for a multi-way adaptive method is presented that use a balanced adaptivity in the grid refinement, the iterative solvers and a homotopy method which leads from a well-understood selfadjoint problems to non-selfadjoint problems. The method is still under development and there are many open problems, but partial results for the solution of eigenvalue problem associated with convection-diffusion problems are presented.

To model the propagation of acoustic waves inside a car, the 3D lossless wave equation is used, which is obtained from the continuity equation together with the Euler equations of fluid dynamics.

Let v, ρ, p denote the particle velocity, the particle density, and the pressure, respectively, all depending on cartesian coordinates x, y, z and time t . Then under several simplifying assumptions, that there is no temperature change, that the fluid is inviscid, that the influence of external forces is restricted to those coming from displacements of the structure at the boundaries, that the fluid is adiabatic, that we have an ideal gas, and finally that $(v \cdot \nabla)v$ and $\rho \frac{\partial v}{\partial t}$ are small, one obtains a simplified system of partial differential equations

$$\frac{1}{c^2} \frac{\partial^2 p}{\partial t^2} + \rho_0 \nabla \frac{\partial v}{\partial t} = \Delta p + \rho_0 \nabla \frac{\partial v}{\partial t} = 0,$$

where c is the speed of sound and ρ_0 is an average density. This system is completed by appropriate initial and boundary conditions. The boundary conditions are obtained from the displacement of the structure to obtain the fluid structure interaction. With u being the vector of displacements of the structure on the surface. $v = \frac{\partial u}{\partial t}$, with the outer normal ν and by incorporating appropriate damping models, we obtain a variational formulation

$$\begin{aligned} \int_V \frac{1}{\rho_0 c^2} w \frac{\partial^2 p}{\partial t^2} dV &+ \int_S w \frac{r}{\rho_0^2 c^2} \frac{\partial p}{\partial t} dS \\ &+ \int_V \frac{1}{\rho_0} (\nabla w) \nabla p dV = - \int_S \nu w \frac{\partial^2 u}{t^2} dS \end{aligned}$$

which has to hold for all test functions w , where S is a surface element. Applying finite element discretization in space, we get a second order system of implicit

differential equations in descriptor form

$$M_f \ddot{p}_d + D_f \dot{p}_d + K_f p_d + D_{sf} \ddot{u}_d = 0,$$

where $M_f = M_f^T$ is a positive definite mass matrix, $K_f = K_f^T$ is a positive definite stiffness matrix, D_f is a symmetric positive semidefinite damping/absorption matrix, and D_{sf} describes the fluid structure coupling.

For the displacement vector u_d in the different finite elements of the discretized structure, assuming linear material laws, one obtains via discrete finite element modeling another linear second order system of differential-algebraic equations

$$M_s \ddot{u}_d + D_s \dot{u}_d + K_s u_d = f_e + f_p,$$

where f_e is a (discrete) external load and f_p is the pressure load. Here M_s is a symmetric positive semidefinite mass matrix, and D_s is a symmetric positive semidefinite damping matrix; both are real. The matrix K_s has the form $K_s = K_1 + \iota K_2$ with real symmetric K_1, K_2 , where K_1 is the positive semidefinite stiffness matrix, which is often frequency dependent to model nonlinear material behavior. The matrix K_2 which is typically of small rank, models hysteretic damping. The mass matrix M_s is highly singular due to the fact that rotational masses are omitted. On the positive side, it is block diagonal with small blocks.

Including the coupling of the fluid part and the structure part of the system via the term f_p that originates from the pressure load and put all equations together, we obtain a second order system of differential-algebraic equations $M\ddot{x} + D\dot{x} + Kx = f$ given by

$$\begin{bmatrix} M_s & 0 \\ D_{sf}^T & M_f \end{bmatrix} \begin{bmatrix} \ddot{u}_d \\ \ddot{p}_d \end{bmatrix} + \begin{bmatrix} D_s & 0 \\ 0 & D_f \end{bmatrix} \begin{bmatrix} \dot{u}_d \\ \dot{p}_d \end{bmatrix} + \begin{bmatrix} K_s(\omega) & -D_{sf}^T \\ 0 & K_f \end{bmatrix} \begin{bmatrix} u_d \\ p_d \end{bmatrix} = \begin{bmatrix} f_s \\ 0 \end{bmatrix}.$$

Since the structure is essentially modeled with a fine and uniform mesh, the matrices have dimensions of several millions. The coefficient matrices also depend on geometry, topology and material parameters.

In the optimization process typically the low frequencies associated with the eigenvalues in the neighborhood the imaginary axis

$$Q(\lambda) := \lambda^2 M + \lambda D + K,$$

are to be damped. Thus it is natural to use modal reduction, i.e., to project the problem into the invariant subspace associated with these eigenvalues.

Typically, when a uniform mesh is used in the discretization, then this would require the need for an nonlinear eigensolver for the large scale eigenvalue problems. There are many methods available for these kind of problems [5]. Due to the difficulties (as described in [4]), which include the need for an out-of-core sparse solver, very good starting values for Newton-type methods, error estimates and condition estimates, it became clear that for a long term development an adaptive eigensolver for the described problem class is needed. The development of such a solver is still mainly an open problem in particular in the context of industrial applications.

To start this development, and to gain experience before approaching the much harder acoustic problem, the construction of an adaptive method for the solution of a model convection/diffusion problem was initiated i.e.:

Determine a non-trivial eigenpair $(\lambda, u) \in \mathbb{C} \times H_0^1(\Omega; \mathbb{C}) \cap H_{loc}^2(\Omega; \mathbb{C})$ with $\|u\|_{L^2(\Omega; \mathbb{C})} = 1$ such that

$$-\Delta u + \beta \cdot \nabla u = \lambda u \text{ in } \Omega \quad \text{and} \quad u = 0 \text{ on } \partial\Omega$$

for some bounded Lipschitz domain $\Omega \subseteq \mathbb{R}^2$ and a constant vector $\beta \in \mathbb{R}^2$.

The corresponding weak formulation then takes the form: *For two complex Hilbert spaces $V := H_0^1(\Omega; \mathbb{C})$ with norm $\|\cdot\| := |\cdot|_{H^1(\Omega; \mathbb{C})}$ and $H := L^2(\Omega; \mathbb{C})$ with norm $\|\cdot\|_{L^2(\Omega; \mathbb{C})}$ determine a non-trivial eigenpair $(\lambda, u) \in \mathbb{C} \times V$ with $b(u, u) = 1$ such that*

$$a(u, v) + c(u, v) = \lambda b(u, v) \quad \text{for all } v \in V.$$

Here $\overline{(\cdot)}$ denotes complex conjugation and, for all $u, v \in V$,

$$a(u, v) := \int_{\Omega} \nabla u \nabla \overline{v} dx, \quad c(u, v) := \int_{\Omega} \overline{v} (\beta \cdot \nabla u) dx, \quad b(u, v) := \int_{\Omega} u \overline{v} dx.$$

For the analysis and the construction of an adaptive method it is necessary to consider also the dual eigenvalue problem:

Determine a non-trivial dual eigenpair $(\lambda^, u^*) \in \mathbb{C} \times V$ with $b(u^*, u^*) = 1$ with*

$$a(w, u^*) + c(w, u^*) = \overline{\lambda^*} b(w, u^*) \quad \text{for all } w \in V.$$

Approximating the solution in a finite dimensional subspace $V_\ell \subseteq V$, we obtain the discretized primal and dual problems:

Determine non-trivial primal and dual eigenpairs $(\lambda_\ell, u_\ell) \in \mathbb{C} \times V_\ell$ and $(\lambda_\ell^, u_\ell^*) \in \mathbb{C} \times V_\ell$ such that*

$$\begin{aligned} a(u_\ell, v_\ell) + c(u_\ell, v_\ell) &= \lambda_\ell b(u_\ell, v_\ell) \quad \text{for all } v_\ell \in V_\ell, \\ a(w_\ell, u_\ell^*) + c(w_\ell, u_\ell^*) &= \overline{\lambda_\ell^*} b(w_\ell, u_\ell^*) \quad \text{for all } w_\ell \in V_\ell. \end{aligned}$$

But even for this problem the general analysis and appropriate methods are still open, so the simpler problem of computing a λ that is simple and well-separated from the rest of the spectrum is discussed.

It has been observed in [3] that it is not enough to just consider the adaptivity in the grid refinement, but that also in the iterative solution of the discretized problems. Furthermore, the analysis of the general nonsymmetric case is extremely sensitive to good starting values for the nonlinear iteration and also for the algebraic eigensolver. To achieve this, a homotopy method is the method of choice and also the adaptivity in the homotopy needs to be considered. Such a homotopy interpolates e.g. between the pure diffusion problem and the full convection diffusion problem, via

$$\mathcal{H}(t) = -\Delta u + t\beta \cdot \nabla u \quad \text{for } 0 \leq t \leq 1.$$

t	$\tilde{\lambda}_\ell(t)$	$\frac{ \lambda_\ell(1) - \tilde{\lambda}_\ell(t) }{ \lambda_\ell(1) }$	#DOF	CPU time
0.0000	20.31171	0.83037	65	0.04
0.2500	25.86284	0.78401	112	0.25
0.5000	44.52525	0.62815	661	0.45
0.7500	75.97150	0.36553	3613	0.88
0.8750	96.37374	0.19514	6538	5.20
0.9375	107.66847	0.10081	21936	22.60
0.9688	113.63394	0.05099	40027	53.26
0.9844	116.67842	0.02556	71610	194.81
0.9922	118.19399	0.01290	226196	358.30
1.0000	119.76367	0.00020	685571	587.75

TABLE 1. Eigenvalue approximation $\tilde{\lambda}_\ell(t)$, relative error $\frac{|\lambda_\ell(1) - \tilde{\lambda}_\ell(t)|}{|\lambda_\ell(1)|}$, degrees of freedom, CPU time for homotopy steps.

To get adaptivity also in the homotopy one uses a 'time'-stepping procedure with nodes $t_0 = 0 < t_1 < \dots < t_N = 1$ to compute the eigenvalues and eigenvectors of

$$\mathcal{H}(t_i)u = -\Delta u + t_i\beta \cdot \nabla u = \lambda u \quad \text{in } \Omega.$$

In [2] a posteriori error estimates for three errors are derived, the approximation error for the finite dimensional weak formulation, the error produced by the iterative algebraic eigensolver (for which we use a few steps of an implicitly restarted Arnoldi method), and the error in the homotopy. An algorithm is presented that balances these three errors so that a minimal computational effort is achieved. The analytical results are illustrated by numerical examples for the model problem such as in Table 1.

Challenges: Although much progress has been made, see also [1, 6], many open problems remain.

- The results need to be extended to problems with nonreal and multiple eigenvalues.
- The efficiency and the convergence properties of the method must be analyzed.
- Nonlinear eigenvalue problems like those for the acoustic field need to be studied.

REFERENCES

- [1] C. Cartensen and J. Gedicke. *An oscillation-free adaptive FEM for symmetric eigenvalue problems*, Numer. Math., **118**, 2011, 401–427.
- [2] C. Carstensen, J. Gedicke, V. Mehrmann, and A. Miedlar, *An adaptive homotopy approach for non-selfadjoint eigenvalue problems* Preprint 718, DFG Research Center MATHEON, [url: http://www.matheon.de/](http://www.matheon.de/). To appear in Numer. Math., 2011.
- [3] V. Mehrmann and A. Miedlar, *Adaptive Computation of Smallest Eigenvalues of Elliptic Partial Differential Equations*, Num. Lin. Alg. Appl., **18**, 2011, 387–409.

- [4] V. Mehrmann and C. Schröder, *Nonlinear eigenvalue and frequency response problems in industrial practice* In revision: Int. J. on Math. in Industry, 2011.
- [5] V. Mehrmann and H. Voss, *Nonlinear Eigenvalue Problems: A Challenge for Modern Eigenvalue Methods* Mitt. der GAMM, **27**, 2005, 121–151.
- [6] A. Miedlar, *Inexact adaptive finite element methods for elliptic PDE eigenvalue problems*, Dissertation, TU Berlin, March 2011.

Parallel solution methods for Maxwell’s eigenvalue problem

CHRISTIAN WIENERS

(joint work with Daniel Maurer, Alexander Bulovyatov, and Jiping Xin)

The standard approach for the computation of eigenvalues of the Maxwell problem is based on a discretization with Nédélec finite elements. Sufficiently fast and efficient methods require iterative eigenvalue solver together with preconditioner of optimal complexity. Here, we present results with a projected LOBPCG method (introduced by Knyazev) combining a three-term recursion with Ritz-Galerkin steps of the Krylov space with projections onto the divergence-free vector fields. The LOBPCG method is preconditioned by a robust Maxwell multigrid solver with hybrid Hiptmair-smoother (applied to the shifted Maxwell operator), and for the projection a Laplace multigrid solver is used. The eigenvalue solver is called in a nested hierarchy, so that on the fine mesh levels only a few LOBPCG iterations are required.

We consider several applications with complex geometries where the coarse mesh is quite large. For this purpose we introduce a parallel direct coarse problem solver [3] which is based on the principle of nested dissection and parallel cyclic distributed Schur complements. This allows a very fast application of the LOBPCG method on the coarse level and is also used as coarse problem solver within the multigrid preconditioner on finer levels. For the application to Maxwell problems we use a symmetric version of the parallel direct solver [2]. We also apply this method to the computation of the photonic band gap structure with requires to solve a series of quasi-periodic eigenvalue problems in the periodicity cell [1,5].

Alternatively, we introduce a boundary element discretization for the Maxwell cavity problem with different subdomains coupled by Calderon projections. Following an idea of Steinbach/Unger for the Helmholtz problem, a Newton method can be used to find eigenvalues by computing nontrivial solutions of the Maxwell cavity problem [6]. Both methods are illustrated by several numerical examples which are realized within the parallel finite element software M++ [4].

REFERENCES

- [1] A. BULOVIATOV, *Parallel multigrid methods for the band structure computation of 3D photonic crystals with higher order finite elements*, Ph.D. thesis, Karlsruhe Institute of Technology, 2010.
- [2] D. MAURER AND C. WIENERS, *Parallel multigrid methods and coarse grid LDL^T solver for Maxwell’s eigenvalue problem*, in Proc. of the CiHPC 2010: Competence in High Performance Computing, G. Wittum, ed., Gauß-Allianz, Springer, pp. 1–9. (to appear).

- [3] ———, *A parallel block LU decomposition method for distributed finite element matrices*, *Parallel Computing*, (2011). to appear.
- [4] C. WIENERS, *A geometric data structure for parallel finite elements and the application to multigrid methods with block smoothing*, *Computing and Visualization in Science*, 13 (2010), pp. 161–175.
- [5] ———, *Calculation of the photonic band structure*, in *Photonic Crystals: Mathematical Analysis and Numerical Approximation*, W. Dörfler, ed., New-York, 2011, Birkhäuser, pp. 40–62.
- [6] J. XIN, *Boundary element approximation for Maxwell's eigenvalue problem*, Ph.D. thesis, Karlsruhe Institute of Technology, 2011.

Accurate Cell-Centered Discretizations for Modeling Multiphase Flow in Porous Media on General Hexahedral and Simplicial Grids

MARY WHEELER

(joint work with Guangri Xue, and Ivan Yotov)

We introduce an accurate cell-centered method for modeling Darcy flow on general quadrilateral, hexahedral and simplicial grids, and refer to these discretizations as the multipoint flux mixed finite element methods (MFME). For elliptic PDEs with tensor coefficients the MFME are locally conservative with continuous fluxes and can be viewed within a variational framework as mixed finite element methods with special approximating spaces and quadrature rules. The framework allows handling of hexahedral grids with non-planar faces with the aid of trilinear mappings from physical elements (general hexahedral elements with non-planar faces) to reference cubic elements. Moreover, MFME allow the pressure and velocities to be decoupled (no saddle point system needs to be solved). Since the discretizations are defined locally, both simplicial and/or corner point geometries can be accurately employed with first order convergence on rough grids and superconvergence on smooth grids. We remark that on distorted hexahedra the quadrature rule is non-symmetric.

In addition, there are several multiscale and multiphysics extensions such as the mortar mixed finite element method and the enhanced velocity method that allow for the treatment of non-matching grids with extensions to the coupling of different numerical algorithms and different physics in adjacent subdomains. Also, the variational framework is useful in designing optimal parallel solvers such as algebraic multigrid and auxiliary preconditioning.

We will also discuss a new splitting scheme for modeling multiphase and compositional flows that can treat higher order transport discretizations for saturations or concentrations with possible hysteretic capillary pressure and relative permeabilities on quadrilateral or hexahedra grids. Our approach is based on approximating physically consistent velocities and applying an MFME method of approximating a reference pressure and a discontinuous Galerkin method for saturations. We observe that consistency is important in treating different capillary pressures and hysteresis arising from different rock types. Computational results will be provided.

\mathcal{H}^2 -Matrix Galerkin Approximation

STEFFEN BÖRM

Matrix equations appear naturally in many applications: the inverse X of a matrix A is given by the equation $AX = I$, certain problems in the field of stochastic partial differential equations lead to the equation $AXA = B$, certain problems in control theory can be reduced to the Lyapunov equation $AX + XA = B$. Computing the solution X for systems of dimension n would require n^2 units of storage and at least n^2 arithmetic operations, which makes this approach unattractive for large problems.

By replacing X by a data-sparse approximation \tilde{X} , e.g., using wavelets or hierarchical matrices, efficient methods can be derived. To compute the approximation, a Galerkin approach can be employed: given a subspace \mathcal{M} of $\mathbb{R}^{n \times n}$, we multiply by test matrices using the Frobenius product to derive a variational formulation in the space of matrices.

Spaces of \mathcal{H}^2 -matrices [1, 2, 3] are a good choice for the trial space \mathcal{M} : The construction uses a *cluster basis*, i.e., a family $(V_t)_{t \in \mathcal{T}}$ of matrices with k columns having certain multilevel properties. A space of \mathcal{H}^2 -matrices is given by

$$\mathcal{M} = \left\{ \sum_{b=(t,s) \in \mathcal{B}} V_t S_b V_s^* : S_b \in \mathbb{R}^{k \times k} \text{ for all } b = (t, s) \in \mathcal{B} \right\},$$

where \mathcal{B} is a subset of $\mathcal{T} \times \mathcal{T}$. The variational form of, e.g., the equation $AXA = B$ is given by

$$\langle AXA, Y \rangle_F = \langle B, Y \rangle_F \quad \text{for all } Y \in \mathbb{R}^{n \times n},$$

and the coefficient matrices S_b of the Galerkin approximation

$$\tilde{X} = \sum_{b=(t,s) \in \mathcal{B}} V_t S_b V_s^*$$

can be computed by solving

$$\sum_{b=(t,s) \in \mathcal{B}} \langle AV_t S_b V_s^* A, V_{t'} S_{b'} V_{s'}^* \rangle_F = \langle B, V_{t'} S_{b'} V_{s'}^* \rangle_F$$

for all $b' = (t', s') \in \mathcal{B}$, $S_{b'} \in \mathbb{R}^{k \times k}$,

where we use $V_{t'} S_{b'} V_{s'}^*$ as trial matrices. This variational formulation is equivalent to the linear system

$$(1) \quad \sum_{b=(t,s) \in \mathcal{B}} (V_{t'}^* A V_t) S_b (V_s^* A V_{s'}) = V_{t'}^* B V_{s'} \quad \text{for all } b' = (t', s') \in \mathcal{B}$$

determining the values of the matrices S_b . In a standard \mathcal{H}^2 -matrix approach, the number of coefficient matrices satisfies $\#\mathcal{B} \in \mathcal{O}(n/k)$, and since each is represented by k^2 coefficients, we have a total of $\mathcal{O}(nk)$ degrees of freedom.

If A is sparse, the matrices $Z_{t',t} := V_{t'}^* A V_t$ can be computed efficiently by a simple recursive algorithm, and it is possible to prove that the set $\{t' \in \mathcal{T} : Z_{t',t} \neq 0\}$ can be bounded by a constant independent of t , i.e., the linear system

(1) is sparse. If A is symmetric positive definite, this property is also inherited by the linear system (1), so we can apply standard algorithms like the Gauß-Seidel iteration or the conjugate gradient method to compute the solution \tilde{X} .

In case of the Gauß-Seidel iteration, we have to solve sub-problems of the form

$$Z_{t,t}S_bZ_{s,s} = V_t^*BV_s - \sum_{\substack{(t',s')=b' \in \mathcal{B} \\ t \neq t', s \neq s'}} Z_{t,t'}S_{b'}Z_{s',s}$$

for all $b = (t, s) \in \mathcal{B}$, and due to $Z_{t,t}, Z_{s,s} \in \mathbb{R}^{k \times k}$, this takes not more than $\mathcal{O}(k^3)$ operations, leading to a total of $\mathcal{O}(nk^2)$ operations for a Gauß-Seidel sweep.

To reach the optimal order of complexity, we can consider a multigrid method. In order to obtain a manageable and energy-stable hierarchy of “discretizations”, the standard \mathcal{H}^2 -matrix structure has to be generalized by constructing \mathcal{T} and \mathcal{B} based on hierarchies of nested finite element meshes similar to the approach used in [4]. The mesh hierarchy can be also used to define a hierarchy of \mathcal{H}^2 -matrix spaces with suitable prolongation and restriction operators, and the Gauß-Seidel algorithm should provide a suitable smoothing iteration.

The proposed method is closely related to wavelet techniques [5, 6], but since wavelets are replaced by purely algebraic cluster bases, it should be possible to handle more general geometries and adapt the cluster bases during the solution process in order to handle problems with non-smooth coefficients more efficiently.

REFERENCES

- [1] W. Hackbusch, B. N. Khoromskij, S. A. Sauter, *On \mathcal{H}^2 -matrices*, Lectures on Applied Mathematics, Springer Berlin (2002), 9–29.
- [2] S. Börm, W. Hackbusch, *Data-sparse approximation by adaptive \mathcal{H}^2 -matrices*, Computing **69** (2002), 1–35.
- [3] S. Börm, *Efficient Numerical Methods for Non-local Operators: \mathcal{H}^2 -Matrix Compression, Algorithms and Analysis*, EMS Tracts in Mathematics **14** (2010)
- [4] S. Börm, S. A. Sauter, *BEM with linear complexity for the classical boundary integral operators*, Math. Comp. **74** (2005), 1139–1177.
- [5] G. Beylkin, R. Coifman, V. Rokhlin, *The fast wavelet transform an numerical algorithms*, Comp. Pure. and Appl. Math. **44** (1991), 141–183.
- [6] A. Cohen, W. Dahmen, R. DeVore, *Adaptive wavelet methods for elliptic operator equations — Convergence rates*, Math. Comp. **70** (2001), 27–75.

Isogeometric Multigrid

CRAIG C. DOUGLAS

(joint work with Victor Calo, Nathan Collier, Hyoseop Lee)

In engineering design, geometry is a major bottleneck in obtaining finite element solutions for a particular problem. A design is usually born inside a CAD package and subsequently needs to be tessellated (or meshed) such that the geometry is approximated by a finite element space. This process, while semi-automatic in some cases, is not without pitfalls and often requires human interaction to verify the resulting mesh. Furthermore, mesh refinements require a return to the CAD

system and a re-tessellation of the CAD object. This means that convergence studies are prohibitively expensive for complex geometries and seldom performed.

Isogeometric analysis [1] has been developed as a solution to this problem, simplifying, and in some cases eliminating, the problem of converting geometric discretizations in the engineering design process. Isogeometric analysis is an isoparametric finite element method that uses the Non-Uniform Rational B-spline basis (NURBS), which dominates the CAD market. It is hoped that in using this basis form, which is prevalent in the CAD community, that the bridge between analysis and design can be bridged.

A NURBS basis may be h -refined via a process known as knot insertion. This process can be likened to the splitting of elements in traditional finite elements, however knot insertion may also be used to control the continuity between elements. More importantly the knot insertion process may be captured as a linear operator that interpolates a vector from one function space to a refined space exactly. We exploit these operators to develop a multigrid approach for isogeometric systems.

In this talk we introduce isogeometric multigrid analysis and the NURBS basis in more detail as well as define the interpolation operator and finally show numerical results.

REFERENCES

- [1] T. J. R. Hughes, J. Cottrell, Y. Bazilevs, *Isogeometric analysis: CAD, finite elements, NURBS, exact geometry and mesh refinement*, Computer Methods in Applied Mechanics and Engineering, **194** (2005), 4135–4195.

DD for DG

SUSANNE C. BRENNER

(joint work with Andrew T. Barker, Eun-Hee Park, Li-yeng Sung, Kening Wang)

The theory of domain decomposition (DD) for elliptic boundary value problems is by now well-established for standard finite element methods [16, 17, 15]. But the corresponding theory for discontinuous Galerkin (DG) methods is still being developed. The ingredients responsible for the flexibility of DG methods also require new treatments in the design and analysis of domain decomposition algorithms.

For two level additive Schwarz algorithms, the difference in scaling between coarse and fine levels can have an adverse effect on the performance of the preconditioner. For second order problems this can be handled by over-penalizing the coarse problem [12, 14, 1, 2] since in this case the coarse level finite element space contains continuous finite element functions as a subspace. For DG methods for fourth order problems using low order finite elements this approach does not produce an optimal preconditioner [13] even if the overlap among the subdomains is generous, since in this case the coarse level finite element space does not contain C^1 finite element functions as a subspace.

This difficulty can be overcome by including an *enriching* operator in the definition of the operator that connects the coarse level finite element space to the fine level finite element space. The enriching operator maps the coarse level finite element space to the Sobolev space where the continuous problem is posed and it is defined by averaging with image in a C^1 finite element space. By first mapping a coarse grid function into a global Sobolev space and then interpolating into the fine grid space, the adverse scaling effect can be eliminated and all the results for standard finite element methods are recovered [8, 3, 4].

For the analysis of nonoverlapping domain decomposition preconditioners it is convenient to have a trace norm that is equivalent to the energy norm on the space of discrete harmonic functions (second order problems) or the space of discrete biharmonic functions (fourth order problems). For standard finite element methods, the trace norm is just a fractional order Sobolev norm on the boundary of a subdomain. Due to the discontinuous nature of the finite element functions, such Sobolev norms are not well-defined in the case of DG methods. Here enriching operators can be used in the definition of appropriate trace norms [9, 7].

Another difficulty arises in the design of a Bramble-Pasciak-Schatz (BPS) preconditioner [5] for DG methods for fourth order problems. It is due to the mismatch between the finite element space (Lagrange finite elements for second order problems) and the partial differential equation (fourth order). This can be overcome by modifying the degrees of freedom (dofs) on the elements along the interface of the nonoverlapping subdomains so that the discrete biharmonic functions are determined by the dofs along the interface. Using the new dofs and trace norms constructed through an enriching operator, classical results for the BPS preconditioner are extended to a DG method [11] for fourth order problems in [9].

Finally, due to the coupling across inter-element boundaries, the bilinear form defining a DG method is not the sum of local bilinear forms defined on the finite element spaces associated with a nonoverlapping domain decomposition. This creates a complication in the extension of the balancing domain decomposition by constraints (BDDC) method [10] to DG methods. To circumvent this problem, a preliminary decomposition of the finite element space is introduced in [7] so that it is only necessary to develop the BDDC preconditioner for a reduced problem where the global bilinear form is the sum of local bilinear forms. The results for BDDC for standard finite element methods is then extended in [7] to a DG method for second order problems [6] by using a trace norm constructed through an enriching operator.

The techniques developed in our work can also be applied to other DD algorithms and other DG methods.

REFERENCES

- [1] P.F. Antonietti and B. Ayuso. Schwarz domain decomposition preconditioners for discontinuous Galerkin approximations of elliptic problems: non-overlapping case. *M2AN Math. Model. Numer. Anal.*, 41:21–54, 2007.
- [2] P.F. Antonietti and B. Ayuso. Two-level Schwarz preconditioners for super penalty discontinuous Galerkin methods. *Commun. Comput. Phys.*, 5:398–412, 2009.

- [3] A.T. Barker, S.C. Brenner, E.-H. Park, and L.-Y. Sung. Two-level additive Schwarz preconditioners for a weakly over-penalized symmetric interior penalty method. *J. Sci. Comput.*, 47:27–49, 2011.
- [4] A.T. Barker, S.C. Brenner, and L.-Y. Sung. Overlapping schwarz domain decomposition preconditioners for the local discontinuous galerkin method for elliptic problems. *preprint*, 2011.
- [5] J.H. Bramble, J.E. Pasciak, and A.H. Schatz. The construction of preconditioners for elliptic problems by substructuring, I. *Math. Comp.*, 47:103–134, 1986.
- [6] S.C. Brenner, L. Owens, and L.-Y. Sung. A weakly over-penalized symmetric interior penalty method. *Electron. Trans. Numer. Anal.*, 30:107–127, 2008.
- [7] S.C. Brenner, E.-H. Park, and L.-Y. Sung. A bddc preconditioner for a weakly over-penalized symmetric interior penalty method. *preprint*, 2011.
- [8] S.C. Brenner and K. Wang. Two-level additive Schwarz preconditioners for C^0 interior penalty methods. *Numer. Math.*, 102:231–255, 2005.
- [9] S.C. Brenner and K. Wang. An iterative substructuring algorithm for a C^0 interior penalty method. *preprint*, 2011.
- [10] C.R. Dohrmann. A preconditioner for substructuring based on constrained energy minimization. *SIAM J. Sci. Comput.*, 25:246–258, 2003.
- [11] G. Engel, K. Garikipati, T.J.R. Hughes, M.G. Larson, L. Mazzei, and R.L. Taylor. Continuous/discontinuous finite element approximations of fourth order elliptic problems in structural and continuum mechanics with applications to thin beams and plates, and strain gradient elasticity. *Comput. Methods Appl. Mech. Engrg.*, 191:3669–3750, 2002.
- [12] X. Feng and O.A. Karakashian. Two-level additive Schwarz methods for a discontinuous Galerkin approximation of second order elliptic problems. *SIAM J. Numer. Anal.*, 39:1343–1365, 2001.
- [13] X. Feng and O.A. Karakashian. Two-level non-overlapping Schwarz preconditioners for a discontinuous Galerkin approximation of the biharmonic equation. *J. Sci. Comput.*, 22/23:289–314, 2005.
- [14] C. Lasser and A. Toselli. An overlapping domain decomposition preconditioner for a class of discontinuous Galerkin approximations of advection-diffusion problems. *Math. Comp.*, 72:1215–1238, 2003.
- [15] T.P.A. Mathew. *Domain Decomposition Methods for the Numerical Solution of Partial Differential Equations*. Springer-Verlag, Berlin, 2008.
- [16] B. Smith, P. Bjørstad, and W. Gropp. *Domain Decomposition*. Cambridge University Press, Cambridge, 1996.
- [17] A. Toselli and O.B. Widlund. *Domain Decomposition Methods - Algorithms and Theory*. Springer, New York, 2005.

Stable Multilevel Splittings of Boundary Element Spaces

RALF HIPTMAIR

(joint work with Shipeng Mao)

1. DISCRETE FIRST-KIND BOUNDARY INTEGRAL EQUATIONS (BIE)

Boundary value problems for linear second-order partial differential equations with constant coefficients can be recast as so-called first-kind boundary integral equations that are coercive in trace spaces, see [16, Ch. 7] and [21, Ch. 3]. Writing $\Omega \subset \mathbb{R}^3$ for a domain and Γ for its boundary, the relevant trace spaces are $H^{\frac{1}{2}}(\Gamma)$

for the Sobolev space $H^1(\Omega)$ [16, Ch. 3], $\mathbf{H}^{-\frac{1}{2}}(\text{div}_\Gamma, \Gamma)$ for the tangential traces for $\mathbf{H}(\mathbf{curl}, \Omega)$ [4], and $H^{-\frac{1}{2}}(\Gamma)$ for the normal trace for $\mathbf{H}(\text{div}, \Omega)$.

We consider lowest-order piecewise polynomial boundary elements (BEM) built on a triangulation Γ_h of Γ for the conforming Galerkin discretization of the variational form of the BIE. In the case of $H^{\frac{1}{2}}(\Gamma)$, this means choosing trial and test spaces of piecewise linear, continuous functions on Γ (space $\mathcal{S}_1(\Omega_h)$), whereas approximation in $H^{-\frac{1}{2}}(\Gamma)$ can be done with piecewise constant functions (space $\mathcal{Q}_0(\Gamma_h)$), see [21, Sect. 4.1]. In the case of BIE in $\mathbf{H}^{-\frac{1}{2}}(\text{div}_\Gamma, \Gamma)$, Galerkin discretization may rely on surface edge elements [5, 2], also known as RWG boundary elements [20] (space $\mathcal{RT}_0(\Gamma_h)$).

The accurate BEM discretization of boundary integral equations on surfaces in 3D inevitably leads to large linear systems with dense matrices. Their storage, let alone direct solution, will often be impossible with reasonable computational resources. This fundamental difficulty could be overcome by combining matrix compression techniques with iterative Krylov subspace solvers (GMRES, BiCG-Stab). The former rely on local low-rank approximation by interpolation or expansion of the kernel (multipole methods).

The conditioning of the linear systems arising from BEM-Galerkin discretization of first-kind BIE will inevitably deteriorate when increasing the resolution of the trial space, which incurs slow convergence of iterative solvers on fine meshes. Acceleration through preconditioning becomes indispensable, and several strategies have been proposed for discrete first-kind BIE. Very popular is *Calderón preconditioning*, which relies on special identities for boundary integral operators. For $H^{\frac{1}{2}}(\Gamma)$ - and $H^{-\frac{1}{2}}(\Gamma)$ -conforming BEM it was pioneered in [22] and extended to surface edge elements in [3, 8]. It is a special variant of operator preconditioning [11, 15].

2. MULTILEVEL PRECONDITIONING

For the linear systems arising from finite element discretizations multilevel (multigrid) preconditioners often enjoy uniform performance with respect to the resolution of the finite element space. This has been established for elliptic variational problems in $H^1(\Omega)$ [17, 28, 27], and in $\mathbf{H}(\mathbf{curl}, \Omega)$ [10, 14, 29]. The proofs boil down to establishing stability of a splitting $V = \sum_i V_i$ of the approximation space V in the sense that the multilevel norm

$$(1) \quad \|v\|_A^2 = \inf \left\{ \sum_{i=0}^L \|v_i\|_A^2; \quad v_i \in V_i, v = \sum_{i=0}^L v_i \right\}, \quad \forall v \in V.$$

is equivalent to the problem induced energy norm $\|\cdot\|_A$ independent of the level of refinement.

Such stability results are available for the BEM spaces $\mathcal{S}_1(\Omega_h) \subset H^{\frac{1}{2}}(\Gamma)$ and $\mathcal{Q}_0(\Gamma_h) \subset H^{-\frac{1}{2}}(\Gamma)$. In [25, 7] stability proofs are given for closed curves, in [18, 1] for surfaces and adaptive refinement. These results were extended to the p and hp version of BEM in [9, 24, 23] and to screen problems in [26]. Here, we extend

them to $\mathcal{RT}_0(\Gamma_h) \subset \mathbf{H}^{-\frac{1}{2}}(\operatorname{div}_\Gamma, \Gamma)$ in the case of multilevel hierarchies created by *uniform refinement*.

3. FROM DOMAIN TO BOUNDARY

Let Ω_h be a tetrahedral mesh, whose restriction to Γ_h spawns the surface mesh Γ_h . From the commuting diagram

$$(2) \quad \begin{array}{ccccc} \mathcal{S}_1(\Omega_h) & \xrightarrow{\mathbf{grad}} & \mathcal{ND}_1(\Omega_h) & \xrightarrow{\mathbf{curl}} & \mathcal{RT}_0(\Omega_h) \\ \downarrow \begin{array}{c} |\partial\Omega \\ \text{(point trace)} \end{array} & & \downarrow \begin{array}{c} \cdot \times \mathbf{n} |_{\partial\Omega} \\ \text{(tangential trace)} \end{array} & & \downarrow \begin{array}{c} \cdot \cdot \mathbf{n} |_{\partial\Omega} \\ \text{(normal trace)} \end{array} \\ \mathcal{S}_1(\Gamma_h) & \xrightarrow{\mathbf{curl}_\Gamma} & \mathcal{RT}_0(\Gamma_h) & \xrightarrow{\operatorname{div}_\Gamma} & \mathcal{Q}_0(\Gamma_h) . \end{array}$$

we learn that the natural trace operators connect finite element spaces and boundary element spaces. This suggests that we *infer stability of multilevel decomposition of BEM spaces from corresponding results for finite element spaces*.

Instrumental is an abstract result by P. Oswald [19, Thm. 1]: Given two Hilbert spaces V , X , a bounded surjective (trace) operator $\mathbb{T} : V \rightarrow X$, a bounded left inverse (extension operator) $\mathbb{E} : X \rightarrow V$, the stability of the splitting $V = \sum_i V_i$ is inherited by the decomposition $X = \sum_i \mathbb{T}(V_i)$, provided that uniformly bounded extension operators $\mathbb{E}_i : \mathbb{T}(V_i) \rightarrow V_i$ can be found. The operator norms of \mathbb{E} , \mathbb{T} , and \mathbb{E}_i will enter the stability bounds, see [12, Sect. 2] for details.

4. STABLE EXTENSION

As explained above, a key for the transfer of stability from multilevel decompositions of the volume edge element space $\mathcal{ND}_1(\Omega_h) \subset \mathbf{H}(\mathbf{curl}, \Omega)$ to $\mathcal{RT}_0(\Gamma_h) \subset \mathbf{H}^{-\frac{1}{2}}(\operatorname{div}_\Gamma, \Gamma)$ is an extension operator $\mathbb{E} : \mathcal{RT}_0(\Gamma_h) \rightarrow \mathcal{ND}_1(\Omega_h)$, which provides a left inverse of the (rotated) tangential trace $\mathbb{T}_t : \mathbf{H}(\mathbf{curl}, \Omega) \rightarrow \mathbf{H}^{-\frac{1}{2}}(\operatorname{div}_\Gamma, \Gamma)$. Its construction is guided by *discrete Hodge decompositions* and employs *discrete potentials*, which is a common theme in the numerical analysis of surface edge elements [13, 6]. The extension of $\boldsymbol{\mu}_h \in \mathcal{RT}_0(\Gamma_h)$ involves the following steps (for topologically trivial Ω) [12, Sect. 5]:

- (1) Perform an $\mathbf{H}(\operatorname{div}, \Omega)$ -extension of the piecewise constant $\operatorname{div}_\Gamma \boldsymbol{\mu}_h$ and interpolate the resulting divergence-free vectorfield in the Raviart-Thomas space $\mathcal{RT}_0(\Omega_h)$.
- (2) Find a discrete vector potential $\in \mathcal{ND}_1(\Omega_h)$, take its tangential trace, and subtract it from $\boldsymbol{\mu}_h$.
- (3) The result has vanishing surface divergence, and, thus, is the \mathbf{curl}_Γ of a discrete scalar surface potential $\varphi_h \in \mathcal{S}_1(\Gamma_h)$.
- (4) The usual discrete extension of φ_h into $\mathcal{S}_1(\Omega_h)$ combined with the vector potential from Step 2 yields $\mathbb{E}\boldsymbol{\mu}_h$.

The proof of an h -uniform bound for the norm of \mathbb{E} resorts to an inverse inequality, which entails a dependence of the bound on quasi-uniformity of the mesh Γ_h . In the case of reasonable quasi-uniformity, for instance, if a multilevel hierarchy of

triangulations $\Gamma_0 \prec \Gamma_1 \prec \Gamma_2 \prec \cdots \prec \Gamma_L$ is created by regular refinement, then we can conclude the stability of the multilevel decomposition

$$\mathcal{RT}_0(\Gamma_h) = \mathcal{RT}_0(\Gamma_0) + \sum_{l=1}^L \left\{ \sum_{e \in \mathcal{E}(\Gamma_l)} \text{Span}(\beta_e^l) + \sum_{\mathbf{p} \in \mathcal{V}(\Gamma_l)} \text{Span}(\mathbf{curl}_\Gamma \beta_{\mathbf{p}}^l) \right\}.$$

Here $\beta_e^l, \beta_{\mathbf{p}}^l$ are the nodal basis functions of $\mathcal{RT}_0(\Gamma_l)$ and $\mathcal{S}_1(\Gamma_l)$, respectively, that are associated with the edge e and the vertex \mathbf{p} of Γ_l . The induced multilevel preconditioner can be implemented with optimal asymptotic computational effort $O(\dim \mathcal{RT}_0(\Gamma_L))$, see [12, Sect. 7].

REFERENCES

- [1] M. AINSWORTH AND W. MCLEAN, *Multilevel diagonal scaling preconditioners for boundary element equations on locally refined meshes*, Numer. Math., 93 (2003), pp. 387–413.
- [2] A. BENDALI, *Numerical analysis of the exterior boundary value problem for time harmonic Maxwell equations by a boundary finite element method. Part 1: The continuous problem*, Math. Comp., 43 (1984), pp. 29–46.
- [3] A. BUFFA AND S. CHRISTIANSEN, *A dual finite element complex on the barycentric refinement*, Math. Comp., 76 (2007), pp. 1743–1769.
- [4] A. BUFFA, M. COSTABEL, AND D. SHEEN, *On traces for $\mathbf{H}(\mathbf{curl}, \Omega)$ in Lipschitz domains*, J. Math. Anal. Appl., 276 (2002), pp. 845–867.
- [5] A. BUFFA AND R. HIPTMAIR, *Galerkin boundary element methods for electromagnetic scattering*, in Topics in Computational Wave Propagation. Direct and inverse Problems, M. Ainsworth, P. Davis, D. Duncan, P. Martin, and B. Rynne, eds., vol. 31 of Lecture Notes in Computational Science and Engineering, Springer, Berlin, 2003, pp. 83–124.
- [6] A. BUFFA, R. HIPTMAIR, T. VON PETERSDORFF, AND C. SCHWAB, *Boundary element methods for Maxwell transmission problems on Lipschitz domains*, Numer. Math., 95 (2003), pp. 459–485.
- [7] T. CAO, *Hierarchical basis methods for hypersingular integral equations*, IMA J. Numer. Anal., 17 (1997), pp. 603–619.
- [8] S. CHRISTIANSEN AND J.-C. NÉDÉLEC, *A preconditioner for the electric field integral equation based on Calderón formulas*, SIAM J. Numer. Anal., 40 (2002), pp. 1100–1135.
- [9] N. HEUER AND E. P. STEPHAN, *An additive Schwarz method for the hp version of the boundary element method for hypersingular integral equations in 3*, IMA Journal of Numerical Analysis, 21 (2001), pp. 265–283.
- [10] R. HIPTMAIR, *Multigrid method for Maxwell’s equations*, SIAM J. Numer. Anal., 36 (1999), pp. 204–225.
- [11] ———, *Operator preconditioning*, Computers and Mathematics with Applications, 52 (2006), pp. 699–706.
- [12] R. HIPTMAIR AND S.-P. MAO, *Stable multilevel splittings of boundary edge element spaces*, Research Report 2011-28, SAM, ETH Zürich, Zürich Switzerland, 2011.
- [13] R. HIPTMAIR AND C. SCHWAB, *Natural boundary element methods for the electric field integral equation on polyhedra*, SIAM J. Numer. Anal., 40 (2002), pp. 66–86.
- [14] R. HIPTMAIR AND W.-Y. ZHENG, *Local multigrid in $\mathbf{H}(\mathbf{curl})$* , J. Comp. Math., 27 (2009), pp. 573–603.
- [15] K.-A. MARDAL AND R. WINTHER, *Preconditioning discretizations of systems of partial differential equations*, Num. Lin. Alg. Appl., 18 (2011), pp. 1–40.
- [16] W. MCLEAN, *Strongly Elliptic Systems and Boundary Integral Equations*, Cambridge University Press, Cambridge, UK, 2000.

- [17] P. OSWALD, *On discrete norm estimates related to multilevel preconditioners in the finite element method*, in Constructive Theory of Functions, Proc. Int. Conf. Varna 1991, K. Ivanov, P. Petrushev, and B. Sendov, eds., Bulg. Acad. Sci., 1992, pp. 203–214.
- [18] P. OSWALD, *Multilevel norms for $H^{-1/2}$* , Computing, 61 (1998), pp. 235–255.
- [19] P. OSWALD, *Interface preconditioners and multilevel extension operators*, in Proc. 11th Intern. Conf. on Domain Decomposition Methods, Greenwich, C.-H. Lai, P. Bjorstad, M. Cross, and O. Widlund, eds., 1999, pp. 96–103.
- [20] S. RAO, D. WILTON, AND A. GLISSON, *Electromagnetic scattering by surfaces of arbitrary shape*, IEEE Trans. Antennas and Propagation, 30 (1986), pp. 409–418.
- [21] S. SAUTER AND C. SCHWAB, *Boundary Element Methods*, vol. 39 of Springer Series in Computational Mathematics, Springer, Heidelberg, 2010.
- [22] O. STEINBACH AND W. WENDLAND, *The construction of some efficient preconditioners in the boundary element method*, Adv. Comput. Math., 9 (1998), pp. 191–216.
- [23] E. STEPHAN, M. MAISCHAK, AND F. LEYDECKER, *Some schwarz methods for integral equations on surfaces– h - and p -versions*, Computing and Visualization in Science, 8 (2005), pp. 211–216.
- [24] T. TRAN AND E. STEPHAN, *Additive Schwarz algorithms for the p -version of the Galerkin boundary element method*, Numer. Math., 85 (2000), pp. 433–468.
- [25] T. TRAN AND E. P. STEPHAN, *Additive Schwarz methods for the h -version boundary element method*, Appl. Anal., 60 (1996), pp. 63–84.
- [26] T. TRAN AND E. P. STEPHAN, *An overlapping additive Schwarz preconditioner for boundary element approximations to the Laplace screen and Lamé crack problems*, J. Numer. Math., 12 (2004), pp. 311–330.
- [27] H.-J. WU AND Z.-M. CHEN, *Uniform convergence of multigrid V -cycle on adaptively refined finite element meshes for second order elliptic problems*, Science in China: Series A Mathematics, 39 (2006), pp. 1405–1429.
- [28] J. XU, *Iterative methods by space decomposition and subspace correction*, SIAM Review, 34 (1992), pp. 581–613.
- [29] J.-C. XU, L. CHEN, AND R. NOCHETTO, *Optimal multilevel methods for $h(\text{grad})$, $h(\text{curl})$, and $h(\text{div})$ systems on graded and unstructured grids*, in Multiscale, non-linear and adaptive approximation, R. DeVore and A. Kunoth, eds., Springer, Berlin, 2009, pp. 599–659.

Model order reduction by reduced basis methods and free-form deformations for shape optimization

ALFIO QUARTERONI

(joint work with Andrea Manzoni, Gianluigi Rozza)

Optimal control and shape optimization problems governed by partial differential equations (PDEs) arise in many applications involving computational fluid dynamics; they can be seen as *many-query problems* since they involve repetitive evaluations of outputs expressed as functionals of field variables. Since they usually require big computational efforts, looking for computational efficiency in numerical methods and algorithms becomes mandatory. We aim at reformulating shape optimization problems as parametric optimization problems, where parameters are geometrical quantities related to shape. In particular, we rely on suitable parametrization paradigms (such as free-form deformation techniques or radial basis functions) in order to describe shapes and deformations in a very low-dimensional but versatile way. We thus exploit the reduced basis method for parametrized problems [1] in order to contain computational efforts. We develop

these techniques in view of haemodynamics applications [2], to control blood flows through the shape optimization of cardiovascular geometries [3].

1. PROBLEM FORMULATION

From an abstract point of view, shape optimization problems can be written as the minimization, over an admissible shape set \mathcal{O}_{ad} , of a cost functional $\mathcal{J}_o(Y(\Omega_o))$

$$(1) \quad \text{find } \hat{\Omega}_o = \arg \min_{\Omega_o \in \mathcal{O}_{ad}} \mathcal{J}_o(Y(\Omega_o))$$

depending on the solution $Y = Y(\Omega_o)$ of a state problem (e.g. under weak form)

$$(2) \quad Y \in \mathcal{Y}(\Omega_o) : \mathcal{A}_o(Y, W; \Omega_o) = \mathcal{F}_o(W; \Omega_o), \quad \forall W \in \mathcal{Y}(\Omega_o);$$

$\mathcal{A}_o(\cdot, \cdot; \Omega_o)$ is a bilinear form and $\mathcal{F}_o(\cdot; \Omega_o)$ is a linear form, both depending on the *original* domain Ω_o where the problem is defined; $\mathcal{Y}(\Omega_o)$ denotes a suitable functional space defined over Ω_o . Assuming that the shape Ω_o depends on a set of *input* parameters $\boldsymbol{\mu} = (\mu_1, \dots, \mu_p) \in \mathcal{D} \subset \mathbb{R}^p$, (1)-(2) can be reduced to a *parametric optimization* problem:

$$(3) \quad \begin{aligned} & \text{find } \hat{\boldsymbol{\mu}} = \arg \min_{\boldsymbol{\mu} \in \mathcal{D}_{ad} \subseteq \mathcal{D}} \mathcal{J}_o(Y(\boldsymbol{\mu})) \quad \text{s.t.} \\ & Y(\boldsymbol{\mu}) \in \mathcal{Y}(\Omega_o(\boldsymbol{\mu})) : \mathcal{A}_o(Y(\boldsymbol{\mu}), W; \boldsymbol{\mu}) = \mathcal{F}_o(W; \boldsymbol{\mu}), \quad \forall W \in \mathcal{Y}(\Omega_o(\boldsymbol{\mu})). \end{aligned}$$

Our approach to shape optimization takes advantage of *reduced basis* (RB) methods for parametrized PDEs [1]. This method is premised upon a classical finite element (FE) method “truth” approximation space $\mathcal{Y}^{\mathcal{N}}$ of (typically very large) dimension \mathcal{N} and is based on the use of “snapshot” FE solutions of the PDEs, corresponding to certain parameter values, as global approximation basis functions previously computed and stored. For this reason, the RB framework requires a reference (parameter independent) domain Ω in order to compare, and combine, FE solutions that would be otherwise computed on different domains and grids; moreover, this procedure enables to avoid shape deformation and remeshing that normally occur at each step of an iterative optimization procedure.

The reference domain Ω is related to the original domain $\Omega_o(\boldsymbol{\mu})$ through a parametric mapping $T(\cdot; \boldsymbol{\mu})$, such that $\Omega_o(\boldsymbol{\mu}) = T(\Omega; \boldsymbol{\mu})$. By tracing (3) back on the reference domain Ω , we obtain the following parametrized formulation:

$$(4) \quad \begin{aligned} & \text{find } \hat{\boldsymbol{\mu}} = \arg \min_{\boldsymbol{\mu} \in \mathcal{D}_{ad}} s(\boldsymbol{\mu}) = \mathcal{J}(Y(\boldsymbol{\mu})) \quad \text{s.t.} \\ & Y(\boldsymbol{\mu}) \in \mathcal{Y} : \mathcal{A}(Y(\boldsymbol{\mu}), W; \boldsymbol{\mu}) = \mathcal{F}(W; \boldsymbol{\mu}), \quad \forall W \in \mathcal{Y}, \end{aligned}$$

where the effect of geometry variations is traced back onto the parametrized operators $\mathcal{A}(\cdot, \cdot; \boldsymbol{\mu})$, $\mathcal{F}(\cdot; \boldsymbol{\mu})$.

2. REDUCTION STRATEGIES

Our reduction framework is based on the coupling between the RB method and suitable shape parametrizations. The combination of these tools allows a considerable reduction in the number of design parameters as well as a computational saving (thanks to the reduced dimension of the linear system associated to the resulting discretized problems). In particular, the mapping $T(\cdot; \boldsymbol{\mu})$ can be

built by exploiting the *free-form deformation* (FFD) technique, in which the deformations of an initial design, rather than the geometry itself, are parametrized [3, 4]. Following the *discretize than optimize* approach, the standard Galerkin FE approximation of (4) is as follows:

$$\begin{aligned} & \text{find } \hat{\boldsymbol{\mu}} = \arg \min_{\boldsymbol{\mu} \in \mathcal{D}_{ad}} s^{\mathcal{N}}(\boldsymbol{\mu}) = \mathcal{J}(Y^{\mathcal{N}}(\boldsymbol{\mu})) \quad \text{s.t.} \\ & Y^{\mathcal{N}}(\boldsymbol{\mu}) \in \mathcal{Y}^{\mathcal{N}} : \mathcal{A}(Y^{\mathcal{N}}(\boldsymbol{\mu}), W; \boldsymbol{\mu}) = \mathcal{F}(W; \boldsymbol{\mu}), \quad \forall W \in \mathcal{Y}^{\mathcal{N}}. \end{aligned}$$

The reduced basis method provides an efficient way to compute an approximation $Y_N(\boldsymbol{\mu})$ of $Y^{\mathcal{N}}(\boldsymbol{\mu})$ (and related output) by using a Galerkin projection on a reduced subspace made up of well-chosen FE solutions, corresponding to a specific choice $S_N = \{\boldsymbol{\mu}^1, \dots, \boldsymbol{\mu}^N\}$ of parameter values. Indicating by $\mathcal{Y}_N^{\mathcal{N}} = \text{span}\{Y^{\mathcal{N}}(\boldsymbol{\mu}^n), n = 1, \dots, N\}$ the RB space, the RB formulation of (4) is as follows:

$$\begin{aligned} & \text{find } \hat{\boldsymbol{\mu}} = \arg \min_{\boldsymbol{\mu} \in \mathcal{D}_{ad}} s_N(\boldsymbol{\mu}) = \mathcal{J}(Y_N(\boldsymbol{\mu})) \quad \text{s.t.} \\ & Y_N(\boldsymbol{\mu}) \in \mathcal{Y}_N^{\mathcal{N}} : \mathcal{A}(Y_N(\boldsymbol{\mu}), W; \boldsymbol{\mu}) = \mathcal{F}(W; \boldsymbol{\mu}), \quad \forall W \in \mathcal{Y}_N^{\mathcal{N}}. \end{aligned}$$

Thanks to the (considerably) reduced dimension $O(N) \ll O(\mathcal{N})$ of the linear systems obtained from RB approximation, we can provide both reliable results and rapid response. In particular, *reliability* is ensured by rigorous a posteriori estimations for the error in the RB approximation w.r.t. truth FE discretization [1, 5], under the form

$$(5) \quad \|Y^{\mathcal{N}}(\boldsymbol{\mu}) - Y_N(\boldsymbol{\mu})\|_{\mathcal{Y}} \leq \Delta_N(\boldsymbol{\mu}) := \frac{\|r(\cdot; \boldsymbol{\mu})\|_{(\mathcal{Y}^{\mathcal{N}})'}}{\beta_{LB}^{\mathcal{N}}(\boldsymbol{\mu})};$$

$r(W; \boldsymbol{\mu}) = \mathcal{F}(W; \boldsymbol{\mu}) - \mathcal{A}(Y_N(\boldsymbol{\mu}), W; \boldsymbol{\mu})$ is the residual and $\beta_{LB}^{\mathcal{N}}(\boldsymbol{\mu})$ is a lower bound of the inf-sup constant $\beta^{\mathcal{N}}(\boldsymbol{\mu}) = \inf_{V \in \mathcal{Y}^{\mathcal{N}}} \sup_{W \in \mathcal{Y}^{\mathcal{N}}} \mathcal{A}(V, W; \boldsymbol{\mu}) / \|V\|_{\mathcal{Y}} \|W\|_{\mathcal{Y}}$.

Rapid response is ensured by an Offline–Online computational strategy which minimizes marginal cost and a rapidly convergent RB space assembling, based on a *greedy algorithm*. To this aim, RB methods rely on the affinity assumption, i.e.

$$(6) \quad \mathcal{A}(Y, W; \boldsymbol{\mu}) = \sum_{q=1}^{Q_{\mathcal{A}}} \Theta_{\mathcal{A}}^q(\boldsymbol{\mu}) \mathcal{A}^q(Y, W), \quad \mathcal{F}(W; \boldsymbol{\mu}) = \sum_{q=1}^{Q_{\mathcal{F}}} \Theta_{\mathcal{F}}^q(\boldsymbol{\mu}) \mathcal{F}^q(W).$$

Hence, in an expensive Offline stage we prepare a very small RB “database”, while in the Online stage, for each new $\boldsymbol{\mu} \in \mathcal{D}$, we rapidly evaluate both the field and the output (with error bounds) whose computational complexity is independent of FE dimension \mathcal{N} . At the outer level, a suitable iterative optimization procedure is performed, now involving a very reduced version of the original problem.

3. STUDY CASES IN HAEMODYNAMICS

This combined “RB+FFD” approach features several advantages: besides being very flexible, it involves the solution of low dimensional problems, yielding substantial computational savings without sacrificing numerical accuracy, even when addressing complex shape optimization problems. To provide a proof of its versatility, we apply it to the design of cardiovascular prostheses [3]; more specifically, we aim at finding the optimal shape of an aorto-coronary bypass graft, which represents the standard treatment of advanced coronary arteries diseases.

Since some correlations between high vorticity areas and post-surgical complications have been established, we are interested in a vorticity minimization problem in a Stokes flow; a Stokes model is appropriate in order to describe low Reynolds number blood flows in mid size arteries, as in the coronary case. The reduced framework described enables to obtain a vorticity reduction of about 45% with a significant (about 100 times) computational speedup w.r.t. traditional FE discretization. Indeed, geometrical reduction in term of the number of parameters is of about 100 with respect to traditional shape parametrizations based on local boundary variation. Nevertheless, in order to deal with more complex fluid dynamics, the extension of this framework to Navier-Stokes equations [6] is in order and represents our current research activity.

REFERENCES

- [1] G. Rozza, D. Huynh, and A. Patera, *Reduced basis approximation and a posteriori error estimation for affinely parametrized elliptic coercive partial differential equations*, Arch. Comput. Methods Engrg. **15** (2008), 229–275.
- [2] G. Rozza, *On optimization, control and shape design of an arterial bypass*, Int. J. Numer. Meth. Fluids **47** (10–11) (2005), 1411–1419.
- [3] A. Manzoni, A. Quarteroni, and G. Rozza, *Shape optimization for viscous flows by reduced basis methods and free-form deformation*, Submitted (2010).
- [4] T. Lassila and G. Rozza, *Parametric free-form shape design with PDE models and reduced basis method*, Comput. Meth. Appl. Mech. Engr. **199** (2010), 1583–1592.
- [5] G. Rozza, D. Huynh, and A. Manzoni, *Reduced basis approximation and error bounds for Stokes flows in parametrized geometries*, Submitted (2010).
- [6] A. Quarteroni and G. Rozza, *Numerical solution of parametrized Navier-Stokes equations by reduced basis methods*, Numer. Meth. PDEs **23** (4) (2007), 923–948.

Reduced-Order Models of Fluids for Simulation, Design and Control

JEFF BORGGGAARD

(joint work with Imran Akhtar, Alexander Hay, Traian Iliescu, and Zhu Wang)

Reduced-order models of fluids find numerous applications where either rapid simulation (such as data assimilation [10, 16], optimization [2] and stochastic partial differential equations [7]) or reduced dimension (such as control [8, 14] or dynamical systems [4, 22]) is required. Most approaches post-process flow simulations to create a low dimensional basis that adequately represents flows of interest using a process known as the proper orthogonal decomposition (POD) (cf. [4, 15, 18, 22]), a variant of the SVD. A dynamical system is created by projecting the Navier-Stokes equations onto this reduced-basis. A typical reduced-order model for the flow velocity field \mathbf{u} has the form

$$(1) \quad \mathbf{u}^r(x, t) = \mathbf{U}(x) + \sum_{j=1}^r \phi_j(x) a_j(t), \quad x \in \Omega, \quad t > 0,$$

where \mathbf{U} is a centering solution (usually a steady-state flow), $\{\phi_j\}_{j=1}^r$ are the POD basis vectors and $\{a_j\}_{j=1}^r$ are temporal coefficients that solve

$$(2) \quad \dot{\mathbf{a}} = \mathbf{b} + \mathbf{A}\mathbf{a} + \mathbf{a}^T \mathbf{B}\mathbf{a}, \quad a_j = \langle \mathbf{u} - \mathbf{U}, \phi_j \rangle, \quad j = 1, \dots, r.$$

The coefficient model above is computed by substituting (1) into the weak form of the Navier-Stokes equations to find the vector \mathbf{b} , matrix \mathbf{A} , and tensor \mathbf{B} .

In this research report, we summarize our contributions toward improving the performance of these models as parameters vary from those used to create the POD modes [1, 12, 13, 11] or when the flows to be modeled exhibit mild turbulence [5, 6, 24, 23]. In the first case, we incorporate parametric derivatives of the POD basis functions in the model by either interpolating/extrapolating basis functions to new parameter values or including the POD derivatives in the basis. This approach assumes that we have derivatives of the flow with respect to parameters of interest available. In the second case, we use the observation that the projection of turbulent flows onto the POD basis exhibits the same energy cascade that is observed in wave number space [9, 19]. Thus, closure terms are added to (2) to account for the influence of discarded POD modes. Similar approaches were first proposed by Aubry et al. [3] with continued developments over the past two decades, e.g. [21, 17]. However, our approach is based on using modern closure models developed in the large eddy simulation community (cf. [20]). To make the implementation of these closure models practicable, we use a two-level discretization approach where the nonlinear closure terms are approximated on a coarse grid to preserve the numerical efficiency of the model [24]. Numerical results from these two areas are presented in the sections below.

1. POD SENSITIVITY ANALYSIS

For models with parameters α , we consider $\phi_j = \phi_j(x; \alpha)$. By computing the derivative of ϕ with respect to parameters, we can either use $\phi(x; \alpha + \Delta\alpha) \approx \phi(x; \alpha) + \Delta\alpha \phi_\alpha(x; \alpha)$ (an extrapolated basis) or expand the consider a POD model for a flow with a geometric parameter change (an expanded basis). We present a test case consisting of two dimensional flow past a square cylinder at Reynolds number 100, where the angle of the square to the fixed incoming flow and channel walls is parameter dependent (see Figure 1, where $\gamma = 22.5^\circ$, $\alpha = 0^\circ$). We compute the relative error (vs. direct numerical simulation) in reduced order models of order 12 over one shedding period and plot the results in Figure 2. We note that the extrapolated basis provides a significant improvement in the reduced order models (nearly an order of magnitude in relative error) at small parameter changes where the extrapolation is expected to be valid. The error in the reduced-order model with the extrapolated basis is comparable to that obtained by projecting the CFD solution onto the basis.

2. POD CLOSURE

In a recent study [23], we used a two-level discretization approach to compare the quality of closure models to direct numerical simulation (DNS). The flow for

FIGURE 1. Flow past a cylinder at varying angle of attack, α 

FIGURE 2. Relative errors in reduced-order models

comparison was a mildly turbulent 3D flow around a circular cylinder at a Reynolds number of 1,000. We compared straight-forward POD-Galerkin (2), the mixing length model proposed by Aubry et al. [3], a Smagorinsky model, a variational multiscale model (VMS) and the dynamic subgrid-scale model (DS). The latter two models are considered to be state-of-the-art in LES modeling [20]. We used a very low-dimensional model, $r = 6$ (capturing 84% of the energy), to emphasize the need for closure modeling. The results, provided in [23] with supporting material at http://www.math.vt.edu/people/wangzhu/POD_3DNumComp.html, showed that the POD-Galerkin model was unstable and thus required closure terms. For the mixing length model, we tuned the parameter to give the best agreement for $t \in (0, 15)$, but found the model to be overly diffusive when used to simulate the flow over $t \in (0, 300)$. The Smagorinsky model gave decent performance, but both VMS and DS models gave very good qualitative agreement with the DNS.

We note that we have provided analogues to the usual notions of large eddy simulation. Filtering is carried out by Galerkin projection to the truncated basis and length-scales are defined by the square-root of the average of the discarded

portion of the kinetic energy over the trace of the discarded portion of the strain-rate tensor squared (providing units of length). This can be precomputed and thus does not need additional heuristic or data fitting. Thus, this approach can be generalized to other flows without the need of tuning coefficients in the model. A drawback of this approach are the non-polynomial nonlinearities appearing in the closed model

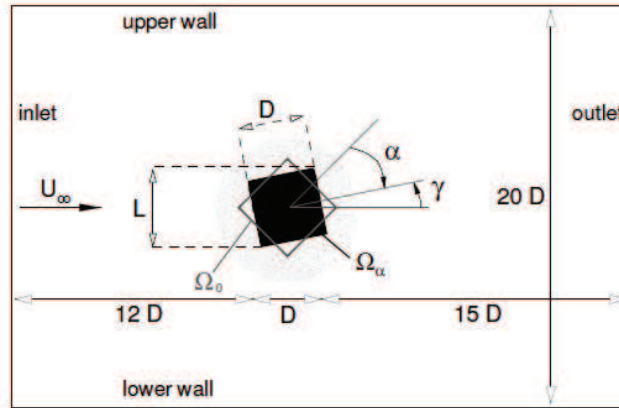
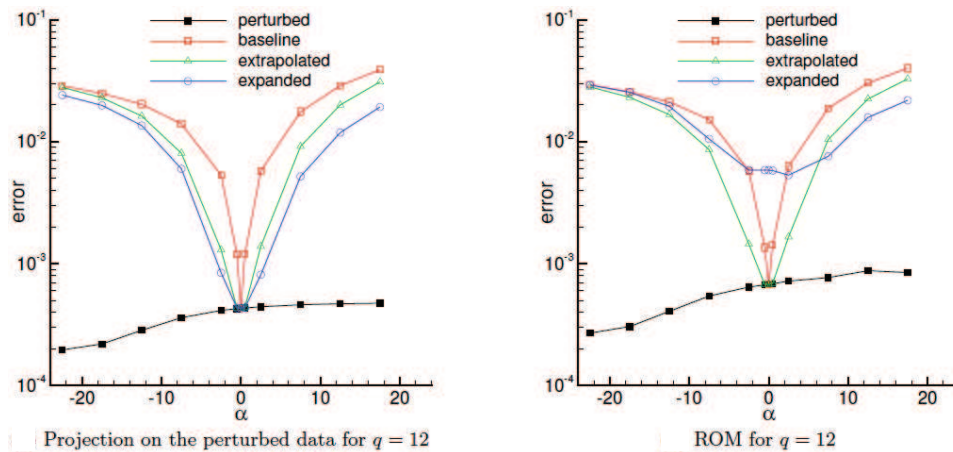
$$\dot{\mathbf{a}} = \left(\mathbf{b} + \tilde{\mathbf{b}}(\mathbf{a}) \right) + \left(\mathbf{A} + \tilde{\mathbf{A}}(\mathbf{a}) \right) \mathbf{a} + \mathbf{a}^T \mathbf{B} \mathbf{a}.$$

The new terms $\tilde{\mathbf{b}}$ and $\tilde{\mathbf{A}}$ are generally expensive since they involve high rank quantities. They can, however, be approximated effectively on a coarse mesh which makes these closure models practicable.

REFERENCES

- [1] I. Akhtar, J. Borggaard, and A. Hay. Shape sensitivity analysis in flow models using a finite-difference approach. *Mathematical Problems in Engineering*, 2010. Article ID 209780.
- [2] E. Arian, M. Fahl, and E. W. Sachs. Managing POD models by optimization methods. In *Proc. 41st IEEE Conference on Decision and Control*, number ThP04-6, pages 3300–3305, 2002.
- [3] N. Aubry, P. Holmes, J. L. Lumley, and E. Stone. The dynamics of coherent structures in the wall region of a turbulent boundary layer. *Journal of Fluid Mechanics*, 192:115–173, 1988.
- [4] G. Berkooz, P. Holmes, and J. L. Lumley. The proper orthogonal decomposition in the analysis of turbulent flows. *Annual Review of Fluid Mechanics*, 25:539–575, 1993.
- [5] J. Borggaard, A. Duggeby, A. Hay, T. Iliescu, and Z. Wang. Reduced-order modeling of turbulent flows. In *Proceedings of the 18th International Symposium on Mathematical Theory of Networks & Systems*, 2008.
- [6] J. Borggaard, T. Iliescu, and Z. Wang. Artificial viscosity proper orthogonal decomposition. *Mathematical and Computer Modelling*, 53(1–2):269–279, 2011.
- [7] J. Burkardt, M.D. Gunzburger, and C. Webster. Reduced order modeling of some nonlinear stochastic partial differential equations. *International Journal of Numerical Analysis and Modeling*, 4(3–4):368–391, 2007.
- [8] J. A. Burns and B. B. King. A reduced basis approach to the design of low-order feedback controllers for nonlinear continuous systems. *Journal of Vibration and Control*, 4:297–323, 1998.
- [9] M. Couplet, P. Sagaut, and C. Basdevant. Intermodal energy transfers in a proper orthogonal decomposition–Galerkin representation of a turbulent separated flow. *Journal of Fluid Mechanics*, 491:275–284, 2003.
- [10] F. Fang, C. C. Pain, I. M. Navon, M. D. Piggott, G. J. Gorman, P. A. Allison, and A. J. H. Goddard. Reduced-order modelling of an adaptive mesh ocean model. *International Journal for Numerical Methods in Fluids*, 59(8), 2009.
- [11] A. Hay, J. Borggaard, I. Akhtar, and D. Pelletier. Reduced-order models for parameter dependent geometries based on shape sensitivity analysis. *Journal of Computational Physics*, 229(4):1327–1352, 2010.
- [12] A. Hay, J. Borggaard, and D. Pelletier. On the use of sensitivity analysis to improve reduced-order models. In *Proc. AIAA Flow Control Conference*, 2008. AIAA Paper 2008-4192.
- [13] A. Hay, J. Borggaard, and D. Pelletier. Local improvements to reduced-order models using sensitivity analysis of the proper orthogonal decomposition. *Journal of Fluid Mechanics*, 629:41–72, 2009.
- [14] K. Ito and S. S. Ravindran. A reduced order method for simulation and control of fluid flows. *Journal of Computational Physics*, 143(2):403–425, 1998.

- [15] J. L. Lumley. The structure of inhomogeneous turbulent flows. In A.M. Yaglom, editor, *Atmospheric Turbulence and Radio Wave Propagation*, pages 166–178, 1967.
- [16] Z. Luo, J. Zhu, R. Wang, and I. M. Navon. Proper orthogonal decomposition approach and error estimation of mixed finite element methods for the tropical Pacific Ocean reduced gravity model. *Computer Methods in Applied Mechanics and Engineering*, 196(41-44):4184–4195, 2007.
- [17] B. Noack, M. Schlegel, B. Ahlborn, G. Mutschke, M. Morzynski, P. Comte, and G. Tadmor. A finite-time thermodynamics of unsteady fluid flows. *Journal of Non-Equilibrium Thermodynamics*, 33(2):103–148, 2008.
- [18] B. R. Noack and H. Eckelmann. A low-dimensional Galerkin method for the three-dimensional flow around a circular cylinder. *Physics of Fluids*, 6:124–143, 1994.
- [19] B. R. Noack, P. Papas, and P. A. Monkewitz. Low-dimensional Galerkin model of a laminar shear-layer. Technical Report 2002-01, École Polytechnique Fédérale de Lausanne, May 2002.
- [20] P. Sagaut. *Large Eddy Simulation for Incompressible Flows: An Introduction*. Springer, Berlin, Heidelberg, New York, 2001.
- [21] S. Sirisup and G. E. Karniadakis. A spectral viscosity method for correcting the long-term behavior of POD models. *Journal of Computational Physics*, 194:92–116, 2004.
- [22] L. Sirovich. Turbulence and the dynamics of coherent structures, part I: Coherent structures. *Quarterly of Applied Mathematics*, 45(3):561–571, 1987.
- [23] Z. Wang, I. Akhtar, J. Borggaard, and T. Iliescu. Proper orthogonal decomposition closure models for turbulent flows: A numerical comparison. *Journal of Fluid Mechanics*. submitted.
- [24] Z. Wang, I. Akhtar, J. Borggaard, and T. Iliescu. Two-level discretizations of nonlinear closure models for proper orthogonal decomposition. *Journal of Computational Physics*, 230:126–146, 2011.

Convergence and quasi-optimality of an adaptive finite element method for controlling L_2 errors

ROB STEVENSON

(joint work with Alan Demlow)

Consider the elliptic model problem

$$(1) \quad \begin{aligned} -\Delta u &= f \text{ in } \Omega, \\ u &= 0 \text{ on } \partial\Omega, \end{aligned}$$

where $\Omega \subset \mathbb{R}^n$, $n \geq 2$, is a convex polyhedral domain and $f \in L_2(\Omega)$.

We prove contraction and quasi-optimality properties for an adaptive finite element method (AFEM) for controlling errors in the $L_2(\Omega)$ -norm. An AFEM is an iterative feedback procedure of the form

$$(2) \quad \text{solve} \rightarrow \text{estimate} \rightarrow \text{mark} \rightarrow \text{refine}.$$

Such adaptive algorithms have for many years been a standard tool for efficiently approximating solutions to partial differential equations such as (1). The convergence properties of AFEM have become the subject of intense theoretical study only in the past few years, however. We refer to [6], [11], [10], [13], and [12] for an overview of progress in basic convergence theory for AFEM for linear elliptic problems. Optimal convergence rates were demonstrated in [14] and [3]. A common feature of most theoretical results published to date concerning convergence

and quasi-optimality of AFEM is that the error estimated in the “estimate” step in (2) is the global energy error. In particular, AFEM optimality results for error notions whose analysis require nontrivial duality arguments have not to our knowledge appeared in the literature. AFEM for controlling other norms are sometimes of practical interest, however; in the current context we refer for example to [15], [9], [4] where “pollution effects” of global solution properties on the local energy error are measured and controlled adaptively in L_2 .

In order to describe our results, let $(\mathcal{T}_i)_{i \geq 0}$ be a nested sequence of conforming, uniformly shape regular partitions of Ω produced by the AFEM. In this work, we consider simplicial partitions as they are produced by the *newest vertex bisection* algorithm or by its generalization to more than two dimensions. Let $S_i \subset H_0^1(\Omega)$ be the standard Lagrange finite element space of some fixed degree k on \mathcal{T}_i , and let $u_i \in S_i$ satisfy

$$(3) \quad A(u_i, v_i) := \int_{\Omega} \nabla u_i \cdot \nabla v_i \, dx = \int_{\Omega} f v_i \, dx, \quad (v_i \in S_i).$$

We also let $|||v||| := \sqrt{A(v, v)}$ and $|||v|||_D := (\int_D |\nabla v|^2 \, dx)^{1/2}$ denote the global and local energy (semi)norms over D , respectively.

Our first goal is to prove that the AFEM for controlling the L_2 -error $\|u - u_i\|_{L_2(\Omega)}$ is majorized linearly convergent. In order to obtain this result, we require that the sequence $(\mathcal{T}_i)_i$ of partitions is sufficiently mildly graded. We will modify the “refine” routine so that, if necessary, it bisects additional simplices in order to preserve the mild grading of the partition. With this modification, and under the assumption that Ω is convex, in a sequence of estimates we prove that the quantities $\|u - u_i\|_{L_2(\Omega)}^2 + \text{osc}_i^2$, $|||h_i(u - u_i)|||^2 + \text{osc}_i^2$ and η_i^2 are all uniformly equivalent. Here osc_i is the L_2 -oscillation term, $h_i \in W_{\infty}^1(\Omega)$ is a regularized local mesh size function, and η_i is the residual based L_2 a posteriori error estimator. A key ingredient of many of our proofs is that thanks to the mild grading of the partitions, the mesh size function can be designed so that $\|\nabla h_i\|_{L_{\infty}(\Omega)}$ is sufficiently small. Following an idea from [3], we then show that a suitably weighted sum of $|||h_i(u - u_i)|||^2$ and η_i^2 is contracted by the AFEM, which implies the convergence result.

The approach of treating the L_2 -error as a *weighted* energy error and then employing techniques developed for proving convergence of AFEM for global energy errors was used earlier in [4] to prove convergence of an AFEM for controlling local energy errors. We note that the restriction that $\|\nabla h_i\|_{L_{\infty}(\Omega)}$ must be sufficiently small has previously appeared in the literature in connection with a priori and a posteriori estimates in L_{∞} (cf. [7], [8]) and a priori estimates in L_2 (cf. [2]).

Convergence of AFEM for controlling L_2 -errors was also addressed in [12]. There are several substantial differences between our approach and the one taken in the latter work. [12] obtains convergence of AFEM for controlling weak norms under quite general assumptions on the marking strategy and norm of interest. While the assumptions are general, the convergence result obtained is correspondingly weak in that no estimate of the rate of convergence is obtained. In contrast,

we require stronger assumptions; aside from the above-mentioned mesh restriction we also require a Dörfler-type marking strategy. The result is a much stronger convergence theory.

Our second main theorem states that for the sequence of partitions produced by the AFEM, $\|u - u_i\|_{L_2(\Omega)} + \text{osc}_i$ can be bounded by some absolute multiple of $(\#\mathcal{T}_i)^{-s}$ for the best possible value of s . To arrive at this quasi-optimality result, we prove a localized a posteriori upper bound for the L_2 -difference between Galerkin solutions on nested partitions. Furthermore, we show that, up to an oscillation term, the Galerkin solution is a near best approximation to u from the finite element space in the L_2 -norm. The latter result is of some interest independent of the current context, since it is known that the Ritz projection is *not* stable in the L_2 norm (cf. [1]). Both of these results rely on the condition that $\|\nabla h_i\|_{L_\infty(\Omega)}$ is sufficiently small. Finally, we show that, even if additional bisections are made to preserve the mild grading of the partitions, at any stage in the AFEM the cardinality of the current partition can be bounded by the cardinality of the initial partition plus some absolute multiple of the number of all elements that so far were marked for refinement by the routine “mark”.

We finally comment on the practicality of the AFEM for which we prove optimality. Existing AFEM optimality results for global energy norms require that an essential user-supplied parameter in the “mark” step be sufficiently small. The L_2 AFEM for which we prove optimality requires *two* user-supplied parameters to be sufficiently small, one in the “mark” and the other in the “refine” step. Whereas in the energy case an upper bound for the parameter in terms of interpolation (Poincaré) constants can in principal be derived theoretically, this will be harder in the L_2 -case as the corresponding parameters additionally depend on H^2 regularity constants.

It should also be noted that enforcing mild mesh grading may exacerbate the asymptotic nature of our results, since meshes satisfying a mild grading assumption with small μ will essentially remain quasi-uniform over the first iterations of the adaptive algorithm. On the other hand, practical experience seems to indicate that optimality in L_2 is obtained without taking precautions to keep the mesh sufficiently mildly graded, although there is no proof of that. This might mean either that that mildly gradedness is not really needed, or that that the typical meshes resulting from the application of an adaptive routine are automatically sufficiently mildly graded. Concerning the latter, note that a mesh that is optimal for controlling L_2 errors is more mildly graded than that for H^1 errors.

REFERENCES

- [1] I. BABUŠKA AND J. OSBORN, *Analysis of finite element methods for second order boundary value problems using mesh dependent norms*, Numer. Math., 34 (1980), pp 41–62.
- [2] S. C. BRENNER AND L. R. SCOTT, *The mathematical theory of finite element methods*, vol. 15 of Texts in Applied Mathematics, Springer, New York, third ed., 2008.
- [3] J. CASCON, C. KREUZER, R. H. NOCHETTO, AND K. G. SIEBERT, *Quasi-optimal convergence rate for an adaptive finite element method*, SIAM J. Numer. Anal., 46 (2008), pp. 2524–2550.

- [4] A. DEMLOW, *Convergence of an adaptive finite element method for controlling local energy errors*, submitted.
- [5] A. DEMLOW, R. P. STEVENSON, *Convergence and quasi-optimality of an adaptive finite element method for controlling L_2 errors*, Numer. Math., 117(2) (2011), pp. 185–218.
- [6] W. DÖRFLER, *A convergent adaptive algorithm for Poisson's equation*, SIAM J. Numer. Anal., 33 (1996), pp. 1106–1124.
- [7] K. ERIKSSON, *An adaptive finite element method with efficient maximum norm error control for elliptic problems*, Math. Models Methods Appl. Sci., 4 (1994), pp. 313–329.
- [8] K. ERIKSSON AND C. JOHNSON, *Adaptive finite element methods for parabolic problems. II. Optimal error estimates in $L_\infty L_2$ and $L_\infty L_\infty$* , SIAM J. Numer. Anal., 32 (1995), pp. 706–740.
- [9] X. LIAO AND R. H. NOCHETTO, *Local a posteriori error estimates and adaptive control of pollution effects*, Numer. Methods Partial Differential Equations, 19 (2003), pp. 421–442.
- [10] K. MEKCHAY AND R. H. NOCHETTO, *Convergence of adaptive finite element methods for general second order linear elliptic PDEs*, SIAM J. Numer. Anal., 43 (2005), pp. 1803–1827 (electronic).
- [11] P. MORIN, R. H. NOCHETTO, AND K. G. SIEBERT, *Convergence of adaptive finite element methods*, SIAM Rev., 44 (2002), pp. 631–658 (electronic) (2003).
- [12] P. MORIN, K. SIEBERT, AND A. VEESER, *Convergence of finite elements adapted for weaker norms*, in Applied and industrial mathematics in Italy II, vol. 75 of Ser. Adv. Math. Appl. Sci., World Sci. Publ., Hackensack, NJ, 2007, pp. 468–479.
- [13] ———, *A basic convergence result for conforming adaptive finite elements*, Math. Models Methods Appl. Sci., 18 (2008), pp. 707–737.
- [14] R. STEVENSON, *Optimality of a standard adaptive finite element method*, Found. Comput. Math., 7 (2007), pp. 245–269.
- [15] J. XU AND A. ZHOU, *Local and parallel finite element algorithms based on two-grid discretizations*, Math. Comp. 69 (2000), pp. 881–909.

Constructing and Analyzing Non-Standard Error Estimators of Hierarchical-Type

JEFFREY S. OVALL

(joint work with Michael Holst, Ryan Szypowski)

Given a variational problem in a Hilbert space \mathcal{H} ,

$$\text{Find } u \in \mathcal{H} \text{ such that } B[u, v] = F[v] \text{ for all } v \in \mathcal{H} ,$$

and another finite dimensional approximation problem in a subspace $V \subset \mathcal{H}$,

$$(1) \quad \text{Find } \hat{u} \in V \text{ such that } B[\hat{u}, v] = F[v] \text{ for all } v \in V ,$$

a posteriori error estimators of hierarchical type involve the computation of an approximate error function in a finite dimensional auxiliary subspace, $\varepsilon \in W \subset \mathcal{H}$. Such an approach has the philosophical appeal of having computed an object, ε , which is of the same type as that which one wishes to assess, $u - \hat{u}$; and, in principle, gives great flexibility in how it is used for error estimation (error in other norms, functional measures of error) and adaptivity (anisotropic refinement, mesh smoothing). We assume here and below that B is continuous and is either coercive or satisfies inf-sup conditions with respect to an appropriate norm $\|\cdot\|$ on \mathcal{H} , and that F is also continuous with respect to this norm, so that the variational problems above and below are well-posed.

We compute $\varepsilon \in W$ as the solution of a third problem

$$(2) \quad \text{Find } \varepsilon \in W \text{ such that } B[\varepsilon, v] = F[v] - B[\hat{u}, v] \text{ for all } v \in W .$$

It is straight-forward to argue that $c\|\varepsilon\| \leq \|u - \hat{u}\|$, regardless of the choice of space W , but the reverse (reliability) bound requires more effort. The traditional analysis (cf. [1]) assumes that B is an inner-product on \mathcal{H} , with associated norm $\|\cdot\|$, and employs *strong Cauchy inequality* between V and W ,

$$B(v, w) \leq \gamma\|v\| \|w\| \text{ for all } v \in V, w \in W \text{ where } \gamma = \gamma(B, V, W) < 1,$$

and a *saturation assumption*

$$\min_{v \in V \oplus W} \|u - v\| \leq \beta \min_{v \in V} \|u - v\| \text{ where } \beta = \beta(B, F, V, W) < 1,$$

to obtain a reliability bound $\|u - \hat{u}\| \leq [(1 - \gamma^2)(1 - \beta^2)]^{-1/2} \|\varepsilon\|$. In addition to the apparent restriction to symmetric problems, this theoretical approach also seems to limit the type of spaces W which might be considered for approximating $u - \hat{u}$ to those for which $V \oplus W$ is a natural approximation space—an exception to this (again, for symmetric problems) can be found in [2].

Our analysis proceeds along different lines. We begin with the error identity:

$$\text{For all } v \in \mathcal{H}, \hat{v} \in V, \hat{w} \in W, B[u - \hat{u}, v] = B[\varepsilon, w] + B[u - \hat{u}, v - \hat{v} - \hat{w}].$$

The structure of the variational residual $B[u - \hat{u}, v - \hat{v} - \hat{w}] = F[v - \hat{v} - \hat{w}] - B[\hat{u}, v - \hat{v} - \hat{w}]$ is used to decide what type of space W would be appropriate for the problem. In [5], we consider general second-order linear elliptic boundary value problems on polyhedral domains in \mathbb{R}^3 , allowing for anisotropic diffusion, convection, reaction, and discontinuous coefficients which might naturally arise in the finite element analysis of composite materials (for example). Piecewise linear elements on a tetrahedral mesh are used for the approximation problem (1). Using integration-by-parts on the variational residual, we see that “strong” residual consists of two components, a “volumetric” part R , and a “jump” part r associated with the faces. Motivated by this, the space W was chosen to have a degree of freedom associated with each face in the mesh. Specifically, W is chosen to consist of continuous, piecewise cubic functions which vanish on every edge in the mesh—cubic face bubbles. A quasi-interpolant $\hat{v} + \hat{w} \in V \oplus W$ of v is chosen in such a way that it shares local average values with v on faces, as well as on patches of tetrahedra surrounding each vertex. This yields a reliability result of the form

$$\|u - \hat{u}\| \leq C_1 \|\varepsilon\| + C_2 \text{osc}(R, r),$$

where the residual oscillation term $\text{osc}(R, r)$ is “morally” of higher-order, and at any rate can be assessed directly. The residual oscillation term can, in some cases, be reduced to a data oscillation term of the sort appearing, for example, in [3]. In a loose sense, the strong Cauchy inequality and saturation assumption have been replaced in the analysis with properties of a quasi-interpolant and the residual oscillation term; and the assumption of symmetry has been removed entirely. In fact, the reliability bound is established with minimal assumptions beyond what is

necessary for well-posedness of the variational problems—piecewise smooth data is assumed for B and F .

The effectivity of an estimator is generally defined to be the ratio of the estimated error to the actual error. Numerical experiments demonstrate consistently good effectivity of our estimator (around 0.7) over a wide range of problems, including those with convection, strongly anisotropic diffusion, or large jumps in the problem data. This estimator is compared with a standard residual error indicator, and is shown to beat it (sometimes significantly) in terms of effectivity, and also in terms of error reduction in the adaptive method—though both approaches achieve optimal asymptotic convergence rates.

Additionally, the system matrix used for computing ε is shown to be spectrally equivalent to its own diagonal (and therefore easy to “invert”), and this is seen in the experiments as well, where condition numbers the diagonally rescaled systems do not exceed 15, even as the meshes are adaptively refined.

A few obvious questions which remain open at this stage are:

- Can the analysis done in [5] be easily extended to non-linear problems? Preliminary experiments suggest that a positive result should exist.
- Can convergence of an adaptive method be proven for this type of estimator? In [4] adaptive convergence is shown for several estimators which can be shown to be comparable to the standard residual estimator, including an estimator which is called “hierarchical” but is not of the type considered here.
- How well will this sort of analysis carry over to different types of problems (for example, saddle-point problems), and different types of elements (for example, Taylor-Hood or Nedelec)?

REFERENCES

- [1] R.E. Bank, *Hierarchical bases and the finite element method*, Acta Numerica **5** (1996), 1–43.
- [2] F.A. Bornemann, B. Erdmann and R. Kornhuber, *A posteriori error estimates for elliptic problems in two and three space dimensions*, SIAM Journal on Numerical Analysis **33** (1996), 1188–1204.
- [3] W. Dörfler and R.H. Nochetto, *Small data oscillation implies the saturation assumption*, Numerische Mathematik **91** (2002), 1–12.
- [4] C. Kreuzer and K.G. Siebert, *Decay rates of adaptive finite elements with Dörer marking*, Numerische Mathematik **117** (2011), 679–716.
- [5] M. Holst, J.S. Owall and R. Szypowski, *A Robust Error Estimator for Elliptic Problems in \mathbb{R}^3* , Applied Numerical Mathematics **61** (2011), 675–695.

A Comparison of Two-Level Preconditioners based on Multigrid and Deflation

KEES VUIK

(joint work with Jok Tang, Scott MacLachlan, Reinhard Nabben)

The Conjugate Gradient (CG) method is a well-known iterative method for solving large linear systems of equations,

$$(1) \quad Ax = b, \quad A \in \mathbb{R}^{n \times n},$$

whose coefficient matrix, A , is sparse, symmetric, and positive definite (SPD). The convergence rate of CG is naturally bounded in terms of the condition number of A , denoted by $\kappa = \kappa(A) := \frac{\lambda_{\max}(A)}{\lambda_{\min}(A)}$, where $\lambda_{\max}(A)$ and $\lambda_{\min}(A)$ are the largest and smallest nonzero eigenvalues of A , respectively. If κ is large, it is often more favorable to solve a preconditioned system,

$$(2) \quad MAx = Mb,$$

instead of (1) directly. To be effective, the preconditioner, M , should be chosen such that MA has a smaller condition number or more clustered spectrum than A , and so that the matrix-vector product My is cheap to compute, relative to the improvement that such preconditioners provide to the convergence rate. Traditional one-level preconditioners, such as diagonal scaling, basic iterative methods, approximate inverse preconditioning, and incomplete Cholesky preconditioners, are widely used. These preconditioners, however, are well-known to not lead to scalable solution algorithms for applications with highly refined grids or large coefficient ratios. In these applications, preconditioned CG (PCG), with these one-level preconditioners, suffers from slow convergence due to the presence of relatively small or large eigenvalues, which have a harmful influence on the condition number of the coefficient matrix. In what follows, we shall refer to such preconditioners as “one-level” preconditioners, to distinguish them from their “two-level” counterparts introduced next.

An alternative to these preconditioners is to incorporate a second matrix within the preconditioner to improve the performance of PCG, so that the resulting approach gets rid of the effect of both small and large eigenvalues. This combined preconditioning is also known as ‘two-level preconditioning’, and the resulting iterative method is called a ‘two-level PCG method’, abbreviated as ‘2L-PCG’. The term “two-level” arises because the second preconditioner involves the solution of an auxiliary problem that can, in some cases, be associated with a second, coarser discretization of the continuum operator. Examples of 2L-PCG methods include preconditioners based on multigrid, domain decomposition, or deflation techniques, where these methods explicitly rely on preconditioning on two levels, see [4] and the references therein. Generalizing (2), the linear system that is the basis of any PCG method can be expressed as

$$(3) \quad \mathcal{P}Ax = \mathcal{P}b, \quad \mathcal{P} \in \mathbb{R}^{n \times n},$$

where \mathcal{P} is either a one-level or two-level preconditioner. If $\mathcal{P} = M$ for a traditional (one-level) choice of M , we simply recover the standard PCG method in (2). When \mathcal{P} is derived from deflation, domain decomposition, or multigrid approaches, the resulting preconditioners appear, at first glance, to be quite different. However, it has been shown in [4] that some of these methods are closely related, or even equivalent, in their abstract forms.

In this paper, we focus on the comparison between two-level preconditioners inspired by the balancing Neumann-Neumann (BNN), deflation (DEF), and multigrid (MG) approaches. In [3, 4], it was shown that BNN and DEF have almost the same spectral properties, and that these properties are quite similar to those of the multigrid $V(0,1)$ - and $V(1,0)$ -cycle preconditioners, even though these are typically not considered as allowable preconditioners for CG. Here, we will compare preconditioners based on deflation and BNN to the 2L-PCG method that mimics a multigrid $V(1,1)$ -cycle preconditioner, denoted as the MG method. This MG method is not compared with the other methods in [4], since it has very different spectral properties and requires a different theoretical treatment, because of the more general choice of one-level preconditioner allowed within MG. The aim of the current research is to fill this gap and compare the abstract versions of MG, DEF and BNN.

Of course, the MG method and its properties are well-known. Our intention is not to reproduce these results (although some known results needed for the comparison are briefly reviewed), but to compare and connect MG to other well-known 2L-PCG methods. A well-known comparison of multigrid and domain-decomposition preconditioners is that of Xu [6], based on subspace corrections. In [6], it is shown that certain multigrid and domain-decomposition algorithms fall into the same mathematical framework and, consequently, certain choices of the components within the domain-decomposition framework lead, in fact, to a multigrid algorithm. Here, we consider a more abstract formulation than [6] and, as a result, derive a more general result, based on a spectral analysis. A similar spectral analysis for a two-level preconditioner based on multigrid principles has been carried out in [1]. In that paper, a specific choice of the two-level preconditioner based on exact eigenvectors of MA is analyzed, allowing for more pre- and post-smoothing steps per iteration. The resulting two-level preconditioner is called a ‘multiplicative two-grid spectral preconditioner’ and is shown to be effective for many practical applications, particularly when sequences of linear systems must be solved. In this paper, we consider a somewhat more general preconditioner, based on a standard multigrid approach (but considering only one pre- and one post-smoothing step), although eigenvectors of MA are sometimes used to illustrate the theoretical results. A consequence of our main result is that any analysis of multigrid method, can be directly applied to the corresponding domain-decomposition or deflation-based preconditioner.

An important feature of the analysis considered here is that it is based on the assumption that the same algorithmic components are used in all three approaches. Because of their distinct origins, each of the deflation, domain-decomposition, and

multigrid algorithms has, primarily, been analyzed based on typical choices of M and a corresponding coarse-grid correction process appropriate for a particular approach. In contrast, we ask the question of whether one of these approaches is obviously superior when the independent choices of the algorithmic components is removed. Intuitively, we might expect the multigrid-based approach to yield better convergence properties than the other 2L-PCG methods, since it alone relies on the use of two applications of the fine-level preconditioner (in the pre- and post-smoothing steps), in addition to a single coarse-grid correction step per iteration. DEF, on the other hand, has optimal convergence properties in terms of its spectral properties compared with certain other 2L-PCG methods (although not MG), see [4]. Therefore, our comparison focuses on the relationship between the spectral properties of MG and DEF. However, the comparison between MG and BNN is, in some cases, easier to perform, so BNN is also used in the analysis. A numerical comparison of DEF and MG, using components typical of each approach, for problems related to two-phase fluid flow was recently presented in [2]. In that comparison, the performance of a robust multigrid technique is clearly superior to that of deflation; the current research was motivated by our desire to understand whether these results were because of some fundamental difference between the multigrid and deflation frameworks, or because of the differences in the choices made for the components within each algorithm's individual framework.

Several important practical issues are ignored in the analysis that follows. Most significantly, we consider only two-level PCG algorithms. In practice, the multi-level extensions of these algorithms are necessary to ensure the efficiency needed to solve problems with the millions and billions of degrees of freedom currently required in the field of computational science and engineering. Analysis of these approaches, however, is much more technical than their two-level counterparts and is beyond the scope of this paper. Furthermore, we do not aim to address several questions about the sensitivities of these algorithms to the perturbations that naturally arise in their multilevel extensions, such as to that of starting guesses or inexact solves on the coarse level. For some analysis of these questions, see the discussion in [4].

For more details see [5]

REFERENCES

- [1] B. Carpentieri, L. Giraud, and S. Gratton. *Additive and multiplicative two-level spectral preconditioning for general linear systems*, SIAM J. Sci. Comput., **29**(4) (2007), 1593–1612.
- [2] S.P. MacLachlan, J.M. Tang, and C. Vuik. *Fast and robust solvers for pressure-correction in bubbly flow problems*, Journal of Computational Physics, **227**(23) (2008), 9742–9761.
- [3] R. Nabben and C. Vuik. *A comparison of deflation and the balancing preconditioner*, SIAM J. Sci. Comput., **27** (2006), 1742–1759.
- [4] J.M. Tang, R. Nabben, C. Vuik, and Y.A. Erlangga. *Comparison of two-level preconditioners derived from deflation, domain decomposition and multigrid methods*, J. Sci. Comput., **39**(3) (2009), 340–370.
- [5] J.M. Tang, S.P. MacLachlan, R. Nabben, and C. Vuik. *A comparison of two-level preconditioners based on multigrid and deflation*, SIAM J. Matrix Anal. and Appl., **31** (2010), 1715–1739.

- [6] J. Xu. *Iterative methods by space decomposition and subspace correction*, SIAM Rev., **34**(4) (1992), 581–613.

GPU acceleration of PDE solvers

GUNDOLF HAASE

(joint work with Manfred Liebmann, Aurel Neic)

We utilized Graphic Processing Units (GPUs) for accelerating the solution of a 3D potential problem originating from the simulation of a heart's electrical stimulation [3]. The system matrix under investigation is unstructured, symmetric and positive definite. Our algebraic multigrid solver (AMG) is used as preconditioner in the cg algorithm solving the system of equation which allows to solve a system with 25 Mill. unknowns in 1 sec. (setup of AMG) plus 1 sec. (solve) on a 256 core computer (cineca). The solver has been rewritten for the use with GPUs and has been accelerated by a factor of 10 comparing one CPU core with one GPU card [1, 4]. Test on the GPU cluster in Wyoming ($8 \times 8GPU_s$) with Gigabit interconnect showed good parallel speedup on one compute node up to 8 GPUs but the rather slow interconnect didn't allow any speedup when more compute nodes are used. Besides a faster interconnect the use of DD-AMG preconditioners has to be applied and preliminary tests indicate the advantages of this approach.

A different problem class (Euler equations for a gas mixture) has been also transferred to the GPU. This problem is solved explicitly and therefore much better suited for many-core environments. We achieved a speedup of 70 by using a GTX 480 in comparison to one CPU core, i.e., one fermi GPU outperforms a whole server node consisting of 8 Octocore processors. Additionally a parallel efficiency of 50% has been achieved on the full Wyoming cluster [2].

REFERENCES

- [1] G. Haase, M. Liebmann, C. Douglas and G. Plank, *A Parallel Algebraic Multigrid Solver on Graphical Processing Unit*, W. Zhang et al. (Eds.) HPCA 2010, LNCS 5938, pp. 38–47. Springer, Heidelberg, 2010
- [2] M. Liebmann, C. Douglas, G. Haase and Z. Horvath, *Large Scale Simulations of the Euler Equations on GPU Clusters* in Proceedings of DCABES 2010, Hongkong (eds. Q. Guo and Y. Guo), IEEE Computer Society, p. 50-54, 2010
- [3] G. Plank, M. Liebmann, R. Weber dos Santos, E.J. Vigmond and G. Haase, *Algebraic Multigrid Preconditioner for the Cardiac Bidomain Model*, IEEE Transactions on Biomedical Engineering, **54**(4), pp. 585-596, 2007.
- [4] B. Rocha, F. Campos, R. Amorim, G. Plank, R. Weber dos Santos, M. Liebmann and G. Haase, *Accelerating cardiac excitation spread simulations using graphics processing units*, Journal on Concurrency and Computation: Practice and Experience **23** pp. 708-720, 2011

One-step hierarchical preconditioners for higher-order FEM

SABINE LE BORNE

(joint work with Jeff O'vall)

We consider a two-level block Gauss-Seidel iteration for solving systems arising from finite element discretizations employing higher-order elements. A p -hierarchical basis is used to induce this block structure. Using superconvergence results normally employed in the analysis of gradient recovery schemes, we argue that a massive reduction of H^1 -error occurs in the first iterate, so that the discrete solution is adequately resolved in very few iterates—sometimes a single iteration is sufficient.

More precisely, we are interested in efficiently and reliably solving linear systems associated with finite element discretizations of problems of the form

$$(1) \quad \text{Find } u \in \mathcal{H} \text{ such that } B(u, v) = F(v) \text{ for all } v \in \mathcal{H} ,$$

where

$$(2) \quad B(u, v) = \int_{\Omega} K \nabla u \cdot \nabla v + (\mathbf{b} \cdot \nabla u + cu)v \, dx ,$$

$$(3) \quad F(v) = \int_{\Omega} f v \, dx + \int_{\Gamma_N} g v \, ds ,$$

$$(4) \quad \mathcal{H} = H_{0,D}^1(\Omega) = \{v \in H^1(\Omega) : u = 0 \text{ on } \Gamma_D \text{ in the sense of trace}\} .$$

Here, $\Omega \subset \mathbb{R}^2$ is open, bounded and (for simplicity) polygonal, having boundary $\Gamma = \Gamma_D \cup \Gamma_N$ with disjoint *Dirichlet and Neumann* portions Γ_D and Γ_N , respectively. In the present work, for the sake of analysis, we make the assumption that the data functions, K, \mathbf{b}, c, f, g , are smooth on Ω . The matrix K is also assumed to be symmetric and uniformly positive definite throughout the domain. We assume that both F and B are bounded, and we assume, for convenience of exposition, that B is coercive.

We discretize (1) by choosing a finite dimensional subspace $V \subset \mathcal{H}$ and restricting the problem:

$$(5) \quad \text{Find } \hat{u} \in V \text{ such that } B(\hat{u}, v) = F(v) \text{ for all } v \in V .$$

Having chosen a basis $\{\psi_k : 1 \leq k \leq N\}$, we make the obvious identification between coefficient vectors $\mathbf{v} \in \mathbb{R}^N$ and functions $v \in V$, and obtain the following linear system corresponding to (5):

$$(6) \quad \mathbf{A}\mathbf{u} = \mathbf{f} \text{ where } A_{ij} = B(\phi_j, \phi_i) \text{ and } \mathbf{f}_i = F(\phi_i) .$$

It is clear that $B(v, w) = \mathbf{w}^t \mathbf{A}\mathbf{v}$, and when $B(\cdot, \cdot)$ is an inner-product ($\mathbf{b} = \mathbf{0}$), A is symmetric, positive-definite and we have

$$(7) \quad \|\mathbf{v}\|^2 \doteq B(v, v) = \mathbf{v}^t \mathbf{A}\mathbf{v} = \|\mathbf{v}\|_A^2 .$$

The p 'th order, continuous Lagrange finite element spaces associated with the triangulation \mathcal{T} are defined as

$$(8) \quad S_p = \{v \in C(\overline{\Omega}) \cap \mathcal{H} : v|_T \in \mathbb{P}_p \text{ for each } T \text{ in the triangulation}\},$$

where \mathbb{P}_p is the collection of all polynomials of (total) degree $\leq p$.

The most common basis for S_p is the so-called *Lagrange (nodal) basis*. Given an appropriate set of (vertex, edge and interior) nodes, all basis functions are globally continuous, piecewise of degree p , and the basis function associated with a given node has value 1 at that node and vanishes at all other nodes.

In contrast, a *p -hierarchical basis* for S_p is built up from functions of various degrees. In this work we consider hierarchical bases of S_2 and S_4 suggested by the hierarchical splittings

$$S_2 = S_1 \oplus (S_2 \setminus S_1) \quad , \quad S_4 = S_1 \oplus (S_2 \setminus S_1) \oplus (S_4 \setminus S_2) .$$

It is clear that the sparsity pattern of the stiffness matrix A and a priori discretization error estimates are independent of the choice of basis, but we argue that a hierarchical basis can provide *significant* gains in terms of solving the associated linear systems.

Suppose that the bases functions of S_2 are ordered with those associated with vertices before those associated with edges. This induces the natural block structures

$$(9) \quad A^{LB} = \begin{pmatrix} A_{11}^{LB} & A_{12}^{LB} \\ A_{21}^{LB} & A_{22}^{LB} \end{pmatrix} \quad , \quad A^{HB} = \begin{pmatrix} A_{11}^{HB} & A_{12}^{HB} \\ A_{21}^{HB} & A_{22}^{HB} \end{pmatrix}$$

on the global stiffness matrices. Here, ‘‘LB’’ stands for Lagrange basis whereas ‘‘HB’’ denotes a hierarchical basis. It can be shown that both A_{11}^{LB} and A_{22}^{LB} are well-conditioned, so the ill-conditioning of A^{LB} is due to strong coupling by the off-diagonal blocks. In contrast, the ill-conditioning of A^{HB} is ‘‘concentrated’’ in A_{11}^{HB} while A_{22}^{HB} is well-conditioned and the off-diagonal coupling can be shown to be mild because of a *strong Cauchy inequality* in the H^1 -inner-product between the spaces S_1 and $S_2 \setminus S_1$.

We now argue that the initial step of the block Gauss-Seidel iteration provides error reduction which is *significantly* greater than what can be explained by standard contraction arguments. These arguments follow the pattern given in [5], which were given in the context of hierarchical error estimation.

Lemma 1. *Suppose that $u^0 = 0$, and $\phi = \phi_1 + \phi_2 \in V$. Then*

$$\|u - u^1\|_1 \leq C \inf_{w \in V_2} \|u - u_1^1 - w\|_1 \leq C \inf_{\phi \in V} (\|u - \phi\|_1 + \|\phi_1 - u_1^1\|_1) .$$

The constant C is determined by the constants of boundedness (continuity) and either coercivity or the inf-sup condition.

To obtain a practical estimate from Lemma 1, one generally chooses ϕ so that it and ϕ_1 are both suitable (quasi-)interpolants of u . Our arguments below employ super-convergence results of the sort found in [1, 6, 4], which in turn assume a mild approximate mesh symmetry condition.

Theorem 1. *Suppose that the triangulation $\mathcal{T} = \mathcal{T}_h$ satisfies an approximate mesh symmetry condition, and u is sufficiently regular. In the case $V_1 = S_1$ and $V = S_p$ for some $p > 1$, the standard nodal quadratic interpolant $u_q = u_\ell + u_b$, $u_\ell \in S_1$, $u_b \in S_2 \setminus S_1$, satisfies*

$$\begin{aligned} \|u - u^1\|_1 &\leq C(\|u - u_q\|_1 + \|u^1 - u_\ell\|_1) \\ &\leq Ch^{1+\min(1,\sigma)} |\log h|^{1/2} \|u\|_{W^{3,\infty}(\Omega)}. \end{aligned}$$

In the case $V_1 = S_2$ and $V = S_p$ for some $p > 2$, there is a cubic quasi-interpolant $u_c = u_q + u_w$, $u_q \in S_2$ (not the nodal interpolant), $u_w \in S_3 \setminus S_2$ such that

$$\begin{aligned} \|u - u^1\|_1 &\leq C(\|u - u_c\|_1 + \|u^1 - u_q\|_1) \\ &\leq Ch^{2+\min(1/2,\sigma)} (\|u\|_4 + \|u\|_{W^{3,\infty}(\Omega)}). \end{aligned}$$

It is not unreasonable in practice to expect to see $\|u - u^1\|_1 = \mathcal{O}(h^2)$ or $\|u - u^1\|_1 = \mathcal{O}(h^2 |\log h|^{1/2})$ when $V_1 = S_1$, and $\|u - u^1\|_1 = \mathcal{O}(h^2)$ or $\|u - u^1\|_1 = \mathcal{O}(h^2 |\log h|^{1/2})$ when $V_1 = S_2$. Even in more realistic situations in which u possesses a few isolated singularities, and the triangulation is appropriately refined near those singularities, similar convergence is observed when one replaces h with $N^{-1/2}$, where N is the number of vertices, edges, or triangles. A partial explanation of this phenomenon, in the case of the Dirichlet Laplacian, is provided in [2].

A detailed version of this paper, including numerical results for second and fourth order finite element spaces, can be found in [3].

REFERENCES

- [1] R. Bank and J. Xu, *Asymptotically exact a posteriori error estimators. I. Grids with superconvergence*, SIAM J. Numer. Anal. **41** (2003).
- [2] L. Chen and H. Li, *Superconvergence of tetrahedral linear finite elements*, Int. J. Numer. Anal. Model. **3** (2010), 273–282.
- [3] S. Le Borne and J. Owall, *Rapid error reduction for block Gauss-Seidel based on p-hierarchical basis*, submitted to Numerical Linear Algebra with Applications (2011).
- [4] Y. Huang and J. Xu, *Superconvergence of quadratic finite elements on mildly structured grids*, Math. Comp. **77** (2008), 1253–1268.
- [5] J. Owall, *Function, gradient, and Hessian recovery using quadratic edge-bump functions*, SIAM J. Numer. Anal. **45** (2007), 1064–1080.
- [6] J. Xu and Z. Zhang, *Analysis of recovery type a posteriori error estimators for mildly structured grids*, Math. Comp. **73** (2004), 1139–1152.

New Parallel Paradigms for Scientific Computing

ZHEYAO MO

JASMIN uses multi-layered and object-oriented software architecture. Three layers are included. The bottom layer implements the parallel computing and achieves high performance. The middle layer describes the geometries of computational domains and integrates numerical algorithms and fast solvers for partial differential equations. The top layer provides the user interfaces.

In the bottom layer, the kernel data structure is patch. Each patch contains cells indexed by a logical box. Cell-centered, node-centered, side-centered, face-centered, edge-centered, particles, multi-group and other user specified variables can be defined on patches. A SAMR mesh is managed by a patch hierarchy. A hierarchy consists of multiple patch levels and each level consists of multiple patches covering the computational domain. Using the patch-based data structure in each level, parallel algorithms and communications using message passing interfaces (MPI)[2] are designed, load balancing are implemented, dynamic memory are managed, visualization interfaces are provided, parallel I/O and restart are embedded. Numerical interpolations and subroutines for physical boundary conditions are abstractly integrated into the communications across two neighboring levels.

The middle layer integrates many object-oriented software modules for numerical algorithms, geometrical descriptions, fast solvers and time integrators for solution of partial differential equations. Various operators for the numerical interpolations and various grid generation methods for the computational domains are included.

The top layer provides object-oriented user interfaces. Because these interfaces hide parallel programming and MPI communications from users, parallel codes can be written using the serially programming paradigm and can be debugged on personal computer. In fact, based on these interfaces, parallel codes only require users to write serial subroutines or modules for the numerical solutions of physical terms, state of equations, physical parameters, discrete schemes and the fast solvers related with the physics and schemes. So, parallel codes can be rapidly written using different modules oriented to realistic applications. Moreover, the modularization is naturally improved compared to the traditional programming models.

JASMIN has released version 2.0. This version contains 600 thousands of lines of C++/C/Fortran 90/Fortran 77 and it can be installed in various computers such as massively parallel processing machines (MPP), PC-clusters and personal computers.

JASMIN version 2.0 supports various applications using two kind of structured meshes. The first is the uniformed rectangular mesh for which multi-level can be locally refined and coarsened. The second is the multi-block deforming structured mesh for which nodes can dynamically move and neighboring blocks are conforming connected to each other. On these two meshes, particles can be randomly distributed. Based on JASMIN, many applications codes in various fields have been developed and numerical simulation are performed using thousands of processors. These fields cover multi-material hydrodynamics and radiation hydrodynamics, hydrodynamics instability, particle simulations, material sciences, climate forecasting, and so on.

REFERENCES

- [1] Zeyao Mo, Aiqing Zhang, *JASMIN users guide.*, , technical report No. IAPCM-T09-JMJL-01, 2010.
- [2] Zeyao Mo, Zeyao Mo Aiqing Zhang Xiaolin Cao Qingkai Liu, Xiaowen Xu, Hengbin An, Wenbing Pei, Shaoping Zhu, *JASMIN: A Parallel Software Infrastructure for Scientific Computing*, *Front. Comput. Sci. China*, 2010, 4(4):480-488.

Towards Multigrid on Millions of Cores

ROBERT FALGOUT

Multigrid methods are often critical for solving huge linear systems efficiently, and they have demonstrated scalability on hundreds of thousands of processors. However, the petascale architectures on the horizon are expected to have millions of processors, and future exascale machines could have even more. The immense degree of parallelism on these machines requires a similar level of concurrency in the algorithms that run on them. In this talk, we explore the question of scaling multigrid methods to millions of cores, discussing issues such as the so-called idle processor issue. We also analyze several approaches for doing effective smoothing in highly concurrent settings.

The Einstein Constraint Equations, Adaptive Methods for Geometric PDE, and Finite Element Exterior Calculus

MICHAEL HOLST

The Einstein constraint equations have been studied intensively for half a century; our focus in the first part of this lecture is on a thirty-five-year-old open question involving existence of solutions to the constraint equations on space-like hyper-surfaces with arbitrarily prescribed mean extrinsic curvature. Until 2009, all known existence results involved assuming constant (CMC) or nearly-constant (near-CMC) mean extrinsic curvature. We outline a new analysis approach that has allowed for the first existence result without near-CMC assumptions.

In the second part of the lecture, we consider the design of adaptive finite element methods (AFEM) for the nonlinear elliptic systems on Riemannian manifolds. We develop an analysis framework that allows for a proof of convergence of AFEM for the Einstein constraints. We also outline a new analysis approach for surface finite element methods, by first analyzing variational crimes in abstract Hilbert complexes, and then applying this to finite element exterior calculus on hypersurfaces.

Nitsche's method for a transport problem in two-phase incompressible flows

ARNOLD REUSKEN

Let $\Omega \subset \mathbb{R}^d$, $d = 2, 3$, be a convex polygonal domain that contains two different immiscible incompressible phases Ω_1 and Ω_2 . We assume that the interface $\Gamma = \Gamma(t) = \bar{\Omega}_1 \cap \bar{\Omega}_2$ is sufficiently smooth. We consider a model which describes the transport of a dissolved species in a divergence-free velocity field \mathbf{w} , i.e. $\operatorname{div} \mathbf{w} = 0$, as follows:

$$(1) \quad \frac{\partial u}{\partial t} + \mathbf{w} \cdot \nabla u - \operatorname{div}(\alpha \nabla u) = f \quad \text{in } \Omega_i, \quad i = 1, 2, \quad t \in [0, T],$$

$$(2) \quad [\alpha \nabla u \cdot \mathbf{n}]_{\Gamma} = 0, \quad [\beta u]_{\Gamma} = 0,$$

where \mathbf{n} is the unit normal at Γ pointing from Ω_1 into Ω_2 . For a sufficiently smooth function v , $[v]$ denotes the jump of v across Γ . The first interface condition in (2) results from the conservation of mass principle while the second one is the so-called *Henry condition* [1]. The diffusion coefficient α and the Henry coefficient β are positive and piecewise constant in the two subdomains, and thus the solution u is in general *discontinuous across the interface*. For the special case $\beta_1 = \beta_2$ and with a triangulation which is *fitted* to the interface, standard finite element spaces have (close to) optimal approximation properties. Here we allow $\beta_1 \neq \beta_2$ and use triangulations that are *unfitted* (as in level set of VOF approaches), i.e. the interface crosses the elements. We will use a variant of Nitsche's method combined with a special finite element method for the spatial discretization of this problem. From this semi-discrete problem a full discretization is obtained by using a standard θ -scheme for time discretization. We use the same Nitsche method as presented and analyzed for a *stationary* diffusion problem by Hansbo [2]. We apply this method to the *nonstationary* problem described above, with discontinuous solution, and furthermore allow a convection term in (1).

We briefly address a weak formulation of the mass transport problem (1)-(2). For simplicity we only consider homogeneous Dirichlet boundary conditions. Due to the fact that the underlying two-phase fluid dynamics concerns two incompressible immiscible phases it is reasonable to make the following assumption about the velocity field \mathbf{w} : $\operatorname{div} \mathbf{w} = 0$ in Ω_i , $i = 1, 2$, $\mathbf{w} \cdot \mathbf{n} = 0$ at Γ , and $\|\mathbf{w}\|_{L^\infty(\Omega)} \leq c < \infty$. We define $H_0^1(\Omega_1 \cup \Omega_2) := \{v \in L^2(\Omega) \mid v_i \in H^1(\Omega_i), \quad i = 1, 2, \quad v|_{\partial\Omega} = 0\}$, where $v_i := v|_{\Omega_i}$, and

$$H := L^2(\Omega), \quad V := \{v \in H_0^1(\Omega_1 \cup \Omega_2) \mid [\beta v]_{\Gamma} = 0\},$$

$$(u, v)_0 := \int_{\Omega} \beta uv \, dx, \quad u, v \in H,$$

$$(u, v)_{1, \Omega_1 \cup \Omega_2} := (u, v)_{1, \Omega_1} + (u, v)_{1, \Omega_2} = \sum_{j=1}^2 \left(\frac{\partial u}{\partial x_j}, \frac{\partial v}{\partial x_j} \right)_0, \quad u, v \in V.$$

We now introduce the bilinear form

$$a(u, v) := (\alpha u, v)_{1, \Omega_1 \cup \Omega_2} + (\mathbf{w} \cdot \nabla u, v)_0, \quad u, v \in V.$$

We have [3] well-posedness of a weak formulation for the case with a stationary interface:

Lemma 1. *Assume that Γ does not depend on t . Take $f \in H$, $u_0 \in V_{\text{reg}} := \{v \in V \mid v_i \in H^2(\Omega_i), i = 1, 2\}$. There exists a unique $u \in C([0, T]; V_{\text{reg}})$ such that $u(0) = u_0$ and*

$$(3) \quad \left(\frac{\partial u}{\partial t}, v\right)_0 + a(u, v) = (f, v)_0 \quad \text{for all } v \in V.$$

The distributional time derivative satisfies $\frac{\partial u}{\partial t} \in L^2(0, T; V) \cap C([0, T]; H)$.

For the discretization of the transport problem we use an *extended finite element space* (XFEM) combined with *Nitsche's method* for handling the Henry interface condition. Let $\{\mathcal{T}_h\}_{h>0}$ be a family of shape regular triangulations of Ω . A triangulation \mathcal{T}_h consists of triangles T , with $h_T := \text{diam}(T)$ and $h := \max\{h_T \mid T \in \mathcal{T}_h\}$. Let $T_i := T \cap \Omega_i$ be the part of T in Ω_i . We now introduce the finite element space

$$(4) \quad V_h^\Gamma := \{v \in H_0^1(\Omega_1 \cup \Omega_2) \mid v|_{T_i} \text{ is linear for all } T \in \mathcal{T}_h, i = 1, 2\}.$$

Note that $V_h^\Gamma \subset H_0^1(\Omega_1 \cup \Omega_2)$, but $V_h^\Gamma \not\subset V$, since the Henry interface condition $[\beta v_h] = 0$ does not necessarily hold for $v_h \in V_h^\Gamma$. We define $(\kappa_i)_{|T} = \frac{|T_i|}{|T|}$ for all $T \in \mathcal{T}_h$, $i = 1, 2$, and the weighted average $\{v\} := \kappa_1(v_1)_{|T} + \kappa_2(v_2)_{|T}$. Let $(f, g)_\Gamma := \int_\Gamma fg \, ds$ be the $L^2(\Gamma)$ scalar product. We introduce the bilinear form

$$(5) \quad \begin{aligned} a_h(u, v) := & (\alpha u, v)_{1, \Omega_1 \cup \Omega_2} + (\mathbf{w} \cdot \nabla u, v)_0 - ([\beta u], \{\alpha \nabla v \cdot \mathbf{n}\})_\Gamma \\ & - (\{\alpha \nabla u \cdot \mathbf{n}\}, [\beta v])_\Gamma + \lambda h^{-1} ([\beta u], [\beta v])_\Gamma, \end{aligned}$$

with a positive parameter λ . The following consistency result holds [3] : Let $u = u(t) \in V_{\text{reg}}$ be the solution defined in lemma 1. Then $u(t)$ satisfies

$$(6) \quad \left(\frac{\partial u}{\partial t}, v_h\right)_0 + a_h(u, v_h) = (f, v_h) \quad \text{for all } v_h \in V_h^\Gamma, t \in [0, T].$$

For the spatial discretization error we have the following result [3].

Theorem 1. *Assume that Γ does not depend on t . Let $u = u(t) \in V_{\text{reg}}$ be the solution defined in lemma 1 and $u_h = u_h(t) \in V_h^\Gamma$ the solution of (6) with $u_h(0) = \hat{u}_0$. The following holds, with R_h the elliptic projection on V_h^Γ ,*

$$\|u_h(t) - u(t)\|_0 \leq \|\hat{u}_0 - R_h u_0\|_0 + c h^2 \left\{ \|u_0\|_{2, \Omega_1 \cup \Omega_2} + \int_0^t \left\| \frac{\partial u}{\partial t} \right\|_{2, \Omega_1 \cup \Omega_2} d\tau \right\}.$$

From this result we conclude that for the semi-discretization of our transport problem we have an optimal error bound for the spatial discretization.

We give results of some numerical experiments. First we treat an example with a *stationary* interface.

We consider the problem (1)-(2) in the domain $\Omega = (0,1)^3$, which contains two subdomains $\Omega_1 := \{(x,y,z) \in \Omega : z < 0.341\}$ and $\Omega_2 := \Omega \setminus \Omega_1$, with the coefficients $\alpha = (\alpha_1, \alpha_2) := (1, 2)$, $\beta = (\beta_1, \beta_2) := (2, 1)$ and a velocity field $\mathbf{w} := (y(1-z), x, 0)^T$. The exact solution is chosen as

$$(7) \quad u(x, y, z, t) := \begin{cases} \exp(-t) \cos(\pi x) \cos(2\pi y) a z(z+b) & \text{in } \Omega_1, \\ \exp(-t) \cos(\pi x) \cos(2\pi y) z(z-1) & \text{in } \Omega_2, \end{cases}$$

where the constants a and b are determined from the interface conditions (2). For the spatial discretization, we create a uniform grid with mesh size $h = \frac{1}{N}$ ($N = 8, 16, 32$) then refine the elements near the interface two times further. The semi-discretization $u_h(t)$ is approximated by $u_h^*(t)$ using the implicit Euler time-stepping scheme with a (sufficiently small) time step size $\Delta t = 10^{-4}$. In Table 2, the errors $\|u_h^*(T) - u(T)\|_{L^2}$ for $T = 0.15$ are displayed, which are consistent with the theoretical bound $\mathcal{O}(h^2)$ given in theorem 1. For a *stationary* elliptic problem the bound [2] $\|[\beta u_h]\|_{L^2(\Gamma)} \leq ch^{1\frac{1}{2}} \|u\|_{2, \Omega_1 \cup \Omega_2}$ holds. For the *time dependent* case we were not able to derive a theoretical bound for this error quantity. The errors $\|[\beta u_h^*]\|_{L^2(\Gamma)}$ are given in Table 3, which seems to behave like $\mathcal{O}(h)$. The numerical solution for $N = 16$ at $T = 0.15$ in the plane $x = 0.25$ is shown in Figure 1.

N	$\ u_h^*(T) - u(T)\ _{L^2}$	factor	order
8	0.00738506	-	-
16	0.00202308	3.65	1.87
32	0.0005228	3.87	1.95

TABLE 2. Spatial discretization error.

N	$\ [\beta u_h^*(T)]\ _{L^2(\Gamma)}$	factor	order
8	$1.565e-4$	-	-
16	$7.975e-05$	1.96	0.972
32	$3.900e-05$	2.05	1.03

TABLE 3. Henry condition $[\beta u_h^*(T)]_{\Gamma}$.

To investigate the time discretization error, we use a fixed mesh with $N = 16$ and compute a reference solution $u_h^*(t)$ with $\Delta t = 10^{-4}$ in the time interval $[0, 0.2]$. The Euler discretization with time step $\Delta t = \frac{T}{n}$ results in approximations $u_h^n(T)$ of $u_h^*(T)$. For the cases $n = 5, 10, 20$ the temporal errors in the L^2 -norm are given in Table 4. We observe the expected first order of convergence in Δt .

Finally we consider an experiment with a nonstationary interface. We consider the problem (1)-(2) in the unit cube Ω and with $\Omega_1(0)$ a sphere of radius $R = 0.2$ centered at the barycenter of Ω . This sphere is moving with constant velocity $\mathbf{w} = (0, 1, 0)^T$, i.e., $\Omega_1(t) = \Omega_1(0) + t\mathbf{w}$. Let $d(x, t)$ be the distance from the point

n	$\ u_h^n - u_h^*(0.2)\ _{L^2}$	factor	order
5	$1.254e - 05$	-	-
10	$6.092e - 06$	2.06	1.04
20	$3.011e - 06$	2.02	1.02

TABLE 4. Time discretization error.

$x \in \Omega$ to the center of $\Omega_1(t)$. We take the piecewise quadratic solution

$$(8) \quad u(x, t) := \begin{cases} \alpha_2(d(x, t)^2 - R^2) + 0.1 \cdot \beta_2 & \text{in } \Omega_1, \\ \alpha_1(d(x, t)^2 - R^2) + 0.1 \cdot \beta_1 & \text{in } \Omega_2, \end{cases}$$

with coefficients $(\alpha_1, \alpha_2) := (1, 5)$, $(\beta_1, \beta_2) := (2, 1)$. As the XFEM space now is time dependent, we discretize the problem first in time using the implicit Euler method with the time step size $\Delta t = 10^{-4}$. The resulting convection-diffusion-reaction problem is discretized with the Nitsche method. We use a uniform grid with the mesh size $h = \frac{1}{N}$, where $N = 16, 32, 64$. The computed result at $T = 0.1$ is illustrated in the plane $x = 0.5$ in Figure 2.

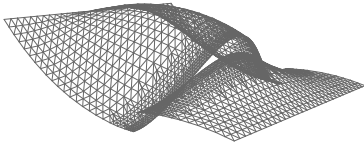
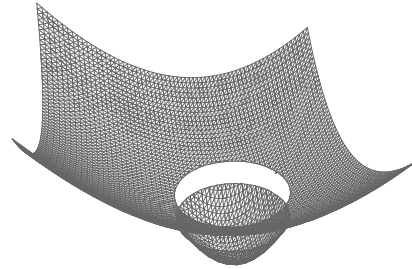
FIGURE 1. Numerical solution in the plane $x = 0.25$.FIGURE 2. Numerical solution in the plane $x = 0.5$.

REFERENCES

- [1] S. Gross, A. Reusken, *Numerical Methods for Two-phase Incompressible Flows*, Springer, Berlin (2011).
- [2] A. Hansbo, A. P. Hansbo, *An unfitted finite element method, based on Nitsche's method, for elliptic interface problems*, Comput. Methods Appl. Mech. Engrg. **191** (2002), 5537–5552.
- [3] A. Reusken, T. Nguyen, *Nitsche's method for a transport problem in two-phase incompressible flows*, J. Fourier Anal. Appl. **15** (2009), 663–683.

Hierarchical Tensor Methods for PDEs with Stochastic Parameters

LARS GRASEDYCK

(joint work with Jonas Ballani, Melanie Kluge)

We consider the problem to solve a (stochastic) parameter dependent equation

$$A(\omega)u(\omega) = b(\omega), \quad \omega \in \Omega$$

for systems A governed by partial differential operators that depend on ω . Our aim is to calculate quantities of interest (mean, variance, maximum etc.) of the set of solutions. One way to solve such a problem is by expansion of the system, the right-hand side as well as the solution in independent uncorrelated stochastic variables $\omega_1, \dots, \omega_p$, and then solve the arising large-scale deterministic problem

$$A(\omega_1, \dots, \omega_p)u(\omega_1, \dots, \omega_p) = b(\omega_1, \dots, \omega_p).$$

An alternative approach is to use (quasi or multilevel) Monte Carlo (MC) methods which require just a simple sampling (M simulations), but these are only useful for certain quantities of interest (e.g. the mean). We present a new approach based on hierarchical Tucker (HT) representations of tensors. This method is based on standard PDE solvers for deterministic systems. The set of solutions is approximated in a low rank (HT) tensor format that allows for many parameters (thousands), since for fixed rank the complexity depends only linearly or quadratically on the number of parameters.

REFERENCES

- [1] L. Grasedyck, *Hierarchical singular value decomposition of tensors*, SIAM J. Matrix Anal. Appl., **31** (2010), 2029–2054.
- [2] J. Ballani and L. Grasedyck and M. Kluge, *Black Box Approximation of Tensors in Hierarchical Tucker Format*, Lin. Alg. Appl., (2011), accepted.

Quantized TT approximation for fast solution of high-dimensional PDEs

BORIS N. KHOROMSKIJ

Modern methods of rank-structured tensor decomposition allow an efficient separable approximation of multivariate functions and operators, providing linear complexity scaling in the dimension. The recent quantized tensor train (QTT) matrix product states technique is proved to provide the super-compressed representation of high-dimensional data with log-volume complexity [1]–[7]. This approach opens the way for efficient numerical solution of high-dimensional PDEs avoiding the “curse of dimensionality” and providing the logarithmic scaling in the grid size. We discuss the asymptotically optimal low QTT-rank representations for a class of multivariate functions and operators, substantiating the computational background of the quantized folding to higher dimensions. In particular, the explicit QTT expansions for a family of discrete multidimensional Hamiltonian operators will be presented. The theory is illustrated by numerical examples in electronic

structure calculations, quantum molecular dynamics and stochastic PDEs.

<http://personal-homepages.mis.mpg.de/bokh>

REFERENCES

- [1] B.N. Khoromskij. *O(d log N)-Quantics Approximation of N-d Tensors in High-Dimensional Numerical Modeling*. J. Constr. Approx. 2011, DOI: 10.1007/s00365-011-9131-1.
- [2] B.N. Khoromskij, V. Khoromskaia, and H.-J. Flad. *Numerical solution of the Hartree-Fock equation in multilevel tensor-structured format*. SIAM J. Sci. Comp., **33**(1), 2011, 45-65.
- [3] B.N. Khoromskij, and Ch. Schwab. *Tensor-Structured Galerkin Approximation of Parametric and Stochastic Elliptic PDEs*. SIAM J. Sci. Comp., **33**(1), 2011, 1-25.
- [4] B.N. Khoromskij, and I. Oseledets. *Quantics-TT collocation approximation of parameter-dependent and stochastic elliptic PDEs*. Comp. Meth. in Applied Math., 10(4):34-365, 2010.
- [5] B.N. Khoromskij, and I. Oseledets. *DMRG+QTT approach to high-dimensional quantum molecular dynamics*. Preprint 68/2010, MPI MiS, Leipzig 2010 (submitted).
- [6] B.N. Khoromskij. *Tensors-structured Numerical Methods in Scientific Computing: Survey on Recent Advances*. Preprint 21/2010, MPI MiS, Leipzig 2010 (submitted).
- [7] B.N. Khoromskij. *Introduction to Tensor Numerical Methods in Scientific Computing*. Lecture Notes, Preprint 06-2011, Uni. of Zuerich, Inst. of Math., 2011. http://www.math.uzh.ch/fileadmin/math/preprints/06_11.pdf

Convolution of \mathbb{R}^n -vectors in $O(\log(n))$

WOLFGANG HACKBUSCH

The translation of a vector into a tensor is called ‘tensorisation’ (cf. [3]). The simplest case is a vector $v \in \mathbb{R}^n$ with $n = 2^d$. Then \mathbb{R}^n is isomorphic to the tensor space $\mathbf{V} := \bigotimes_{j=1}^d \mathbb{R}^2$. The concrete isomorphism is

$$\begin{aligned} \Phi_n : \mathbf{V} &\rightarrow \mathbb{R}^n \\ \mathbf{v} &\mapsto v \quad \text{with } v_k = \mathbf{v}[i_1 \cdots i_d] \text{ for } k = \sum_{j=1}^d i_j 2^{j-1}, 0 \leq i_j \leq 1. \end{aligned}$$

The representation of the tensor \mathbf{v} may be done by the hierarchical tensor format (cf. [4]) with a linear tree leading to the tensor train representation [6] described in the contribution by B. Khoromskij (see also [5]). The tensor train format can be characterised by matrices $M_j[i_j] \in \mathbb{R}^{r_{j-1} \times r_j}$ ($0 \leq i_j \leq 1$) with $r_0 = r_d = 1$ so that

$$\mathbf{v}[i_1 \cdots i_d] = M_1[i_1] M_2[i_2] \cdots M_{d-1}[i_{d-1}] M_d[i_d].$$

Obviously, the storage size is $2 \sum_{j=1}^d r_{j-1} r_j$. The ‘ranks’ r_j are bounded by

$$\min\{2^j, 2^{d-j}\} \leq \sqrt{n}.$$

However, for discrete grid values of (piecewise) analytic functions with possible point singularities one can prove that good approximations require only $r_j \leq \text{const}$ (cf. [1]). In this case the storage size is $O(d) = O(\log n)$. In the following we assume that vectors $v \in \mathbb{R}^n$ are approximated by tensors $\mathbf{v} \in \mathbf{V}$ of data size $O(\log n)$.

The convolution of vectors $v, w \in \mathbb{R}^n$ is defined by

$$(1) \quad u = v \star w \quad \text{with } u_k = \sum_{\ell=\max\{0, k+1-n\}}^{\min\{k, n-1\}} v_\ell w_{k-\ell} \quad (0 \leq k \leq 2n-2).$$

Let $\mathbf{v}, \mathbf{w} \in \mathbf{V}$ be the corresponding tensors, i.e., $\Phi_n(\mathbf{v}) = v$ and $\Phi_n(\mathbf{w}) = w$. Similarly, define $\mathbf{u} \in \mathbf{V}$ by $\Phi_n(\mathbf{u}) = u$. Then we define the convolution of \mathbf{v}, \mathbf{w} by $\mathbf{u} = \mathbf{v} \star \mathbf{w}$. In principle, one may transform the tensors \mathbf{v}, \mathbf{w} into the vectors v, w and apply a fast Fourier transform. However, then the cost is $O(n \log n)$. Instead, we want to perform $\mathbf{v} \star \mathbf{w}$ with a computational cost corresponding to the data size, which is here assumed to be $O(\log n)$.

In the case of a convolution of multivariate functions, tensor algorithms make use of the formula

$$\left(\bigotimes_{j=1}^d f_j \right) \star \left(\bigotimes_{j=1}^d g_j \right) = \bigotimes_{j=1}^d (f_j \star g_j),$$

where $\left(\bigotimes_{j=1}^d f_j \right) (x_1, \dots, x_d) = \prod_{j=1}^d f_j(x_j)$. This leads to the idea that the convolution of elementary tensors $\bigotimes_{j=1}^d v_j, \bigotimes_{j=1}^d w_j \in \mathbf{V}$ may be performed by

$$(2) \quad \left(\bigotimes_{j=1}^d v_j \right) \star \left(\bigotimes_{j=1}^d w_j \right) = \bigotimes_{j=1}^d (v_j \star w_j).$$

Eq. (2) is inconsistent for $v_j, w_j \in \mathbb{R}^2$, since $v_j \star w_j \in \mathbb{R}^3$ (note that (1) shows that u belongs to \mathbb{R}^{2n-1}). The remedy is to consider $\mathbb{R}^2, \mathbb{R}^3$, and \mathbb{R}^n as subsets of

$$\ell_0 = \{(a_\nu)_{\nu \in \mathbb{N}_0} : a_\nu = 0 \text{ for almost all } \nu\}.$$

The embedding $\mathbb{R}^n \subset \ell_0$ implies that $\bigotimes_{j=1}^d \mathbb{R}^2$ can be embedded into $\bigotimes_{j=1}^d \ell_0$. Then, it can be proved that (2) makes sense for $v_j, w_j \in \ell_0$ and is correct. Together with a ‘carry-over’ procedure one obtains an algorithm which produces $\mathbf{u} = \mathbf{v} \star \mathbf{w} \in \bigotimes_{j=1}^{d+1} \mathbb{R}^2$ with a cost corresponding to the data size. Details are given in [2].

REFERENCES

- [1] L. Grasedyck: *Polynomial approximation in hierarchical Tucker format by vector-tensorization*. Submitted 2010.
- [2] W. Hackbusch: *Tensorisation of vectors and their efficient convolution*. Numer. Math., to appear
- [3] W. Hackbusch: *Tensor spaces and numerical tensor calculus*. Monograph in preparation.
- [4] W. Hackbusch and S. Kühn: *A new scheme for the tensor representation*. J. Fourier Anal. Appl. **15** (2009) 706–722.
- [5] B.N. Khoromskij: *$O(d \log N)$ -quantics approximation of N -d tensors in high-dimensional numerical modeling*. Constr. Approx., to appear 2011
- [6] Oseledets, I.V.: *Approximation of matrices using tensor decomposition*. SIAM J. Matrix Anal. Appl. **31**, 2130–2145 (2010)

Models and Simulations of Variable-Density Flow

ALFIO GRILLO

(joint work with Michael Lampe, Dmitriy Logashenko, Sebastian Reiter, Sabine Stichel, Gabriel Wittum)

We report on some studies of variable-density flow in heterogeneous porous media in which the heterogeneity is due to the presence of fractures. Motivated by the investigation of some specific hydrogeological problems, such as groundwater flow in coastal aquifers or around salt domes, we regard fractures as thin fissures which, rather than being part of the void space of the entire porous medium domain, are filled with a porous medium much more permeable than the porous medium enclosing them. In such formations, the heterogeneity of the flow domain is due to the abrupt permeability contrast between the porous media inside and outside the fractures [1].

An incomplete list of references of authors who studied flow in fractured media is [2]–[7].

Simulations of flow in fractured porous media may be carried out by following two main approaches. In the first one, the same flow model and numerical methods are used both for the enclosing medium and the fractures. Thus, if the enclosing medium has dimension d , the fractures are treated as d -dimensional sub-domains. Usually, this approach requires no further reduction of complexity of the flow equations defined in the fractures, and only necessitates the prescription of appropriate transfer conditions at the fracture-medium interfaces. For ideal interfaces, these conditions typically impose that transferred physical quantities be continuous at the interfaces. All physical phenomena can be resolved equally well both in the fractures and in the enclosing medium. This, however, arises some essential problems in the numerical solvers because of the small thickness of the sub-domains representing the fractures. In particular, for media with a large number of intersecting fractures, the generation of a proper computational grid becomes a complicated task, and the convergence of linear solvers deteriorates due to the jumping coefficients of the problem and anisotropy of the grid. The mentioned problems make this approach numerically very expensive and restrict its applicability to the case of a small number of relatively thick fractures. In the second approach, fractures are represented by $(d - 1)$ -dimensional objects, and the d -dimensional model of variable-density flow is averaged along the width of the fractures to obtain a system of $(d - 1)$ -dimensional PDEs [8]. Therefore, the new model, which consists of a system of d -dimensional PDEs defined in the enclosing medium and system of $(d - 1)$ -dimensional PDEs defined in the fractures, is solved numerically. The transfer conditions at fracture-medium interface have to be reformulated accordingly. This second approach is numerically much cheaper than the first one, and proves to be quite reliable for determining the values of both the unknowns in the fractures and the jumps of these unknowns at the sides of the fractures.

The main goal of our contribution is to discuss the validity of the $(d - 1)$ -dimensional model. This is done by comparing the results produced by this model

with the results obtained by means of the d -dimensional approach. To this tend, we compute some benchmark problems corresponding to different thicknesses and locations of fractures in a given flow domain. After recalling the mathematical model, and the averaging technique necessary for our purposes, we report on the used numerical methods and the preparation of the grid. Furthermore, some simulations of benchmark problems involving also heat transport are presented.

REFERENCES

- [1] A. Grillo, D. Logashenko, S. Stichel, G. Wittum, *Simulation of density-driven flow in fractured porous media*, Advances in Water Resources/Elsevier, 33, 1494–1507, 2010.
- [2] P. Angot, F. Boyer, F. Huber, *Asymptotic and numerical modelling of flow in fractured porous media*. ESAIM: M2AN. Mathematical Modelling and Numerical Analysis, 43, 239–275, 2009.
- [3] L. Martinez-Landa, J. Carrera, *A methodology to interpret cross-hole tests in a granite block*. Journal of Hydrogeology/ Elsevier, 325(1-4), 222–240, 2006.
- [4] S. Sorek, V. Borisov, A. Yakirevich, *A two-dimensional areal model for density dependent flow regime*. Transport in Porous Media/ Springer, 43, 87–105, 2001.
- [5] T. Graf, R. Therrier, *Stable-unstable flow of geothermal fluids in fractured rock*. Geofluids/ Wiley, 9, 138–152, 2009.
- [6] J.M.J. Sharp, M. Shi, *Heterogeneity effects on possible salinity-driven free convection in low-permeability strata*. Geofluids/ Wiley, 34, 263–274, 2009.
- [7] C. Voss, W. Souza, *Variable density flow and solute transport simulation of regional aquifers containing a narrow freshwater-saltwater transition zone*. Water Resources Research/ AGU, 26, 2097–2106, 1987.
- [8] J. Bear, *Dynamics of fluids in porous media*. Dover Publications, INC. New York, 1972.

Algebraic Multigrid for Density Driven Flow in Porous Media

ARNE NÄGEL

(joint work with Gabriel Wittum)

In this talk we focus on the development of a fast solver for the problem class of density driven flow in porous media. This coupled system of equations is typically, e.g. [1, 2], written as in terms of the following two conservation equations for the fluid phase and the salt mass fraction:

$$\begin{aligned}\partial_t(\Phi\rho) + \nabla \cdot [\rho\mathbf{q}] &= \rho q_V \\ \partial_t(\Phi\rho\omega) + \nabla \cdot [\rho\omega\mathbf{q} - \rho\mathbb{D}\nabla\omega] &= \rho\omega q_V\end{aligned}$$

The transport depends on the Darcy velocity $\mathbf{q} = -\frac{K}{\mu}(\nabla p - \rho\mathbf{g})$ and a dispersion tensor $\mathbb{D} = \mathbb{D}_{mol} + \mathbb{D}_{mec}(\mathbf{q})$ of Scheidegger-type. The unknowns are the pressure p and the salt mass fraction ω . The density $\rho = \rho(\omega)$ and the viscosity $\mu = \mu(\omega)$ given by non-linear material laws. Porosity Φ , permeability K , gravity \mathbf{g} , and sources q_V are constant or depend on space only.

We seek to solve these equations in the software d^3f [3] which provides a fully non-linear formulation as well as a simplified approximation of Boussinesq-type. One well-known standard strategy is to employ variants of Newton’s method and

hence to decompose the problem into a sequence of linear sub-problems. In this case efficient preconditioning strategies for the solution of the resulting linear systems remain one of the key challenges. Difficulties for the linear solver arise from anisotropies, discontinuous coefficients and fluctuations in the velocity profiles.

Algebraic multigrid methods are one useful tool to cope with these problems while providing almost optimal computational complexity at the same time. In this talk we comment on the *Filtering Algebraic Multigrid* method and introduce its generalisation for systems of coupled PDEs [4, 5]. We adapt this method to the problem of density driven flow: To eliminate large negative diagonal entries resulting in the equation for the salt mass fraction, we present a transformation which locally decouples p and ω . This is related to decoupling preconditioners for two-phase flow [6, 7], but with exchanged roles of p and ω . A robust AMG method moreover requires the choice of appropriate smoothers, and a modified notion of strength of connections. The talk is concluded by several numerical experiments. Future work can be directed towards the development of more efficient smoothers or a modified non-linear solver similar to the Gauss-Seidel-like iterative coupling approach [8].

REFERENCES

- [1] J. Bear and Y. Bachmat. *Introduction to Modeling of Transport Phenomena in Porous Media*. Theory and applications of transport in porous media. Kluwer Academic, Dordrecht, 1991.
- [2] E.O. Holzbecher. *Modeling density-driven flow in porous media*. Springer, Berlin, Heidelberg, 1998.
- [3] E. Fein and A. Schneider. d^3f - Ein Programmpaket zur Modellierung von Dichteströmungen. Technical Report GRS 139, Gesellschaft für Anlagenbau und Reaktorsicherheit (GRS) mbH, October 1999.
- [4] C. Wagner. On the algebraic construction of multilevel transfer operators. *Computing*, 65:73–95, 2000.
- [5] A. Nägel. *Schnelle Löser für große Gleichungssysteme mit Anwendungen in der Biophysik und den Lebenswissenschaften*. PhD thesis, Universität Heidelberg, 2010.
- [6] S. Lacroix, Y.V. Vassilevski, and M.F. Wheeler. Decoupling preconditioners in the implicit parallel accurate reservoir simulator (IPARS). *Numerical Linear Algebra with Applications*, 8(8):537–549, 2001.
- [7] R. Scheichl, R. Masson, and J. Wendebourg. Decoupling and block preconditioning for sedimentary basin simulations. *Computational Geosciences*, 7:295–318, 2003.
- [8] K. Stüben, T. Clees, H. Klie, B. Lu, and M.F. Wheeler. Algebraic Multigrid Methods (AMG) for the Efficient Solution of Fully Implicit Formulations in Reservoir Simulation. Paper SPE 105832 presented at the 2007 SPE Reservoir Simulation Symposium, Houston, TX, Feb. 28-30, 2007.

A robust preconditioned MinRes solver for distributed time-periodic eddy current optimal control problems

ULRICH LANGER

(joint work with Michael Kolmbauer)

We consider forward and backward eddy current problems, discretized by the Multiharmonic Finite Element Method (MH-FEM) or the Multiharmonic Finite Element/ Boundary Element coupling method (MH-FEM/BEM) in bounded and unbounded computational domains Ω , respectively. Hence, we consider the following distributed time-periodic eddy current optimal control problems as model problems: Minimize the cost functional

$$(1) \quad J(\mathbf{y}, \mathbf{u}) = \frac{1}{2} \int_{\Omega \times (0, T)} |\mathbf{y} - \mathbf{y}_d|^2 dx dt + \frac{\lambda}{2} \int_{\Omega \times (0, T)} |\mathbf{u}|^2 dx dt$$

subject to the state equation

$$(2) \quad \begin{cases} \sigma \frac{\partial}{\partial t} \mathbf{y} + \mathbf{curl}(\nu \mathbf{curl} \mathbf{y}) = \mathbf{u} & \text{in } \Omega \times (0, T), \\ \mathbf{y}(0) = \mathbf{y}(T) & \text{in } \bar{\Omega}, \end{cases}$$

with appropriate boundary or decay conditions. So either we solve the state equation (2) for a given source \mathbf{u} (forward problem), or we solve the Karush-Kuhn-Tucker (KKT) system corresponding to the minimization problem (1)-(2) for a prescribed desired state \mathbf{y}_d (backward problem).

It is important to mention, that, for MH-FEM, our analysis covers the case of typical eddy current problems consisting of conducting ($\sigma > 0$) and non-conducting ($\sigma = 0$) domains, if an appropriate regularization is taken into account (elliptic, parabolic or exact regularization). For MH-FEM/BEM, the non-conducting domains are treated by boundary integral operators. Therefore, we consider the following settings:

- 1) MH-FEM for the state equation (2), cf. [6],
- 2) MH-FEM/BEM for the state equation of (2), cf. [7],
- 3) MH-FEM for the KKT-system of (1)-(2), cf. [8],
- 4) MH-FEM/BEM for the KKT-system of (1)-(2).

For the resulting large systems of algebraic equations, we construct and analyze block diagonal preconditioners, that are robust with respect to the space and time discretization parameters h and $k\omega$, as well as all involved “bad” model parameters, like the conductivity σ , the reluctivity ν and the regularization parameters (λ -regularization of the cost functional (1) and ε -regularization of the state equation (2)). The construction of these preconditioners heavily relies on some recent work by Zulehner [9]. These block-diagonal preconditioners can be used for accelerating iterative solution methods like the Minimal Residual Method to obtain parameter-robust (= parameter-independent) convergence rates.

In all four cases the resulting system matrices are block-diagonal and hence decouple into blocks corresponding to the involved modes k , where each block has

the following one-, two- or three-fold saddle point structure:

$$\begin{aligned} \mathcal{A}_1 &= \begin{bmatrix} M_{\sigma, k\omega} & \mathbf{K} \\ \mathbf{K} & -M_{\sigma, k\omega} \end{bmatrix}, \\ \mathcal{A}_2 &= \begin{bmatrix} M_{\sigma, k\omega} & \cdot & \mathbf{K}-\mathbf{N} & \mathbf{B} \\ \cdot & \cdot & \mathbf{B}^T & -\mathbf{A} \\ \mathbf{K}-\mathbf{N} & \mathbf{B} & -M_{\sigma, k\omega} & \cdot \\ \mathbf{B}^T & -\mathbf{A} & \cdot & \cdot \end{bmatrix}, \\ \mathcal{A}_3 &= \begin{bmatrix} M & \cdot & \mathbf{K} & M_{\sigma, k\omega} \\ \cdot & M & -M_{\sigma, k\omega} & \mathbf{K} \\ \mathbf{K} & -M_{\sigma, k\omega} & -\lambda^{-1}M & \cdot \\ M_{\sigma, k\omega} & \mathbf{K} & \cdot & -\lambda^{-1}M \end{bmatrix}, \\ \mathcal{A}_4 &= \begin{bmatrix} M & \cdot & \cdot & \cdot & \mathbf{K}-\mathbf{N} & \mathbf{B} & M_{\sigma, k\omega} & \cdot \\ \cdot & \cdot & \cdot & \cdot & \mathbf{B}^T & -\mathbf{A} & \cdot & \cdot \\ \cdot & \cdot & M & \cdot & -M_{\sigma, k\omega} & \cdot & \mathbf{K}-\mathbf{N} & \mathbf{B} \\ \cdot & \cdot & \cdot & \cdot & \cdot & \cdot & \mathbf{B}^T & -\mathbf{A} \\ \mathbf{K}-\mathbf{N} & \mathbf{B} & -M_{\sigma, k\omega} & \cdot & -\lambda^{-1}M & \cdot & \cdot & \cdot \\ \mathbf{B}^T & -\mathbf{A} & \cdot & \cdot & \cdot & \cdot & \cdot & \cdot \\ M_{\sigma, k\omega} & \cdot & \mathbf{K}-\mathbf{N} & \mathbf{B} & \cdot & \cdot & -\lambda^{-1}M & \cdot \\ \cdot & \cdot & \mathbf{B}^T & -\mathbf{A} & \cdot & \cdot & \cdot & \cdot \end{bmatrix}. \end{aligned}$$

Here $M_{\sigma, k\omega}$ and M correspond to weighted edge FEM mass matrices and \mathbf{K} to a weighted edge FEM stiffness matrix, respectively. The matrices \mathbf{A} , \mathbf{B} and \mathbf{N} correspond to the usual BEM discretized boundary integral operators in the trace space of $\mathbf{H}(\mathbf{curl})$ as use in [1].

Since the system matrices \mathcal{A}_i ($i = 1, 2, 3, 4$) are symmetric and indefinite, we use the preconditioned MinRes method as iterative solver for the corresponding linear systems. Using space interpolation techniques, we can derive the preconditioners

$$\begin{aligned} \mathcal{C}_1 &= \text{diag} [\mathcal{I}_{FEM}^0, \mathcal{I}_{FEM}^0], \\ \mathcal{C}_2 &= \text{diag} [\mathcal{I}_{FEM}^0 + \mathcal{I}_{BEM}, \mathbf{A}, \mathcal{I}_{FEM}^0 + \mathcal{I}_{BEM}, \mathbf{A}], \\ \mathcal{C}_3 &= \text{diag} \left[\sqrt{\lambda} \mathcal{I}_{FEM}^1, \sqrt{\lambda} \mathcal{I}_{FEM}^1, \frac{1}{\sqrt{\lambda}} \mathcal{I}_{FEM}^1, \frac{1}{\sqrt{\lambda}} \mathcal{I}_{FEM}^1 \right] \quad \text{and} \\ \mathcal{C}_4 &= \text{diag} \left[\sqrt{\lambda} (\mathcal{I}_{FEM}^1 + \mathcal{I}_{BEM}), \sqrt{\lambda} \mathbf{A}, \sqrt{\lambda} (\mathcal{I}_{FEM}^1 + \mathcal{I}_{BEM}), \sqrt{\lambda} \mathbf{A}, \right. \\ &\quad \left. \frac{1}{\sqrt{\lambda}} (\mathcal{I}_{FEM}^1 + \mathcal{I}_{BEM}), \frac{1}{\sqrt{\lambda}} \mathbf{A}, \frac{1}{\sqrt{\lambda}} (\mathcal{I}_{FEM}^1 + \mathcal{I}_{BEM}), \frac{1}{\sqrt{\lambda}} \mathbf{A} \right], \end{aligned}$$

for the system matrices \mathcal{A}_1 , \mathcal{A}_2 , \mathcal{A}_3 and \mathcal{A}_4 , respectively. For $i = 0, 1$, the matrices \mathcal{I}_{FEM}^i and \mathcal{I}_{BEM} are defined by the relations

$$\mathcal{I}_{FEM}^i = \mathbf{K} + M_{k\omega, \sigma} + (i/\sqrt{\lambda})M \quad \text{and} \quad \mathcal{I}_{BEM} = -\mathbf{N} + \mathbf{B}\mathbf{A}^{-1}\mathbf{B}^T.$$

The main result of this work is the following:

Theorem 1. *For $i = 1, 2, 3, 4$, we have a parameter-independent condition number bound:*

$$\kappa_{\mathcal{C}_i}(\mathcal{C}_i^{-1}\mathcal{A}_i) := \|\mathcal{C}_i^{-1}\mathcal{A}_i\|_{c_i} \|\mathcal{A}_i^{-1}\mathcal{C}_i\|_{c_i} \leq c_i \neq c_i(h, k\omega, \sigma, \nu, \lambda, \varepsilon),$$

where $c_1 = \sqrt{2}$, $c_2 = 4$, $c_3 = \sqrt{3}$ and $c_4 = 2\sqrt{5}$. Instead of \mathcal{C}_2 , there is another variant of a robust block-diagonal preconditioner, given by

$$\tilde{\mathcal{C}}_2 = \text{diag} [\tilde{\mathcal{I}}_{FEM}, \tilde{\mathcal{I}}_{BEM}, \tilde{\mathcal{I}}_{FEM}, \tilde{\mathcal{I}}_{BEM}],$$

with the blocks

$$\tilde{\mathcal{I}}_{FEM} = \mathbf{K} + \mathbf{M}_{k\omega, \sigma} - \mathbf{N} \quad \text{and} \quad \tilde{\mathcal{I}}_{BEM} = \mathbf{A} + \mathbf{B}^T \tilde{\mathcal{I}}_{FEM}^{-1} \mathbf{B},$$

leading to a condition number estimate of $\kappa_{\tilde{\mathcal{C}}_2}(\tilde{\mathcal{C}}_2^{-1} \mathcal{A}_2) \leq 2\sqrt{7}$. This variant can also be generalized to the optimal control case 4).

In practice, the diagonal blocks of \mathcal{C}_i ($i = 1, 2, 3, 4$) have to be again replaced by robust and optimal preconditioners. Such preconditioners are available, at least, for the diagonal blocks \mathcal{I}_{FEM}^i ($i = 0, 1$), see e.g. [2, 3].

Anyhow, this technique of parameter-robust preconditioning shows great potential, since it allows to reduce a huge, fully space-time discretized system of equations to standard $\mathbf{H}(\mathbf{curl})$ problems.

Additionally, in [5], the MH-FEM is analyzed and applied to time-periodic parabolic optimal control problems (cf. (1)-(2) in the setting 3) with \mathbf{curl} formally replaced by ∇). Furthermore, in [4] this analysis is extended to more general settings, like the case of different control and observation domains, the case of observation in the H^1 -semi norm and the case of constraints for the Fourier coefficients of the control. In all these settings, the block-diagonal preconditioner

$$\mathcal{C}_2^{H^1} = \text{diag} [M_{\sigma, k\omega} + K, M_{\sigma, k\omega} + K, M_{\sigma, k\omega} + K, M_{\sigma, k\omega} + K]$$

leads to robust convergence rates, independent of the space and time discretization parameters h and $k\omega$ and the “bad” model parameters σ and ν . All these results can be extended to the eddy current optimal control problem (1)-(2) as well.

REFERENCES

- [1] R. Hiptmair, *Symmetric coupling for eddy current problems*, SIAM J. Numer. Anal. **40** (2002), 41–65.
- [2] Q. Hu and J. Zou, *A nonoverlapping domain decomposition method for Maxwell’s equations in three dimensions*, SIAM J. Numer. Anal. **41** (2003), 1682–1708.
- [3] Q. Hu and J. Zou, *A weighted Helmholtz decomposition and application to domain decomposition for saddle-point Maxwell systems*, Technical Report **15**, CUHK (2007).
- [4] M. Kollmann and M. Kolmbauer, *A preconditioned MinRes solver for time-periodic parabolic optimal control problems*, in preparation.
- [5] M. Kollmann, M. Kolmbauer, M. Kowalska and U. Langer, *Multiharmonic finite element analysis of a time-periodic parabolic optimal control problem*, in preparation.
- [6] M. Kolmbauer and U. Langer, *A frequency-robust solver for the time-harmonic eddy current problem*, Proceedings of the SCEE 2010 (2011).
- [7] M. Kolmbauer and U. Langer, *A robust FEM-BEM solver for time-harmonic eddy current problems*, Numa-Report 2011-05, Johannes Kepler University Linz, May 2011.
- [8] M. Kolmbauer and U. Langer, *A robust preconditioned-MinRes-solver for distributed time-periodic eddy current optimal control*, Numa-Report 2011-04, Johannes Kepler University Linz, May 2011, <http://www.numa.uni-linz.ac.at/Publications/List/>.
- [9] W. Zulehner, *Non-standard norms and robust estimates for saddle point problems*, Numa-Report 2010-07, Johannes Kepler University Linz, November 2010.

Fast solution of PDE constrained shape optimization problems

VOLKER SCHULZ

(joint work with Nicolas Gauger, Stephan Schmidt, Caslav Ilic)

Shape optimization arises in many fields of applications. This talk focuses on the aerodynamic shape optimization and on the optimization of acoustic horns. Conventional algorithms for shape optimization rely on parameterizations of the shape with comparatively few optimization parameters. Although the adjoint approach is nowadays standard, nevertheless remain certain components within those algorithms, whose complexity is nonlinear. In this talk, an algorithmic framework based on one-shot methods is presented, which profits from shape gradients, as defined by the shape calculus. Furthermore, it is shown that approximations of the shape Hessians can be generated which accelerate the resulting preconditioned steepest descent algorithms significantly. Thus, the overall algorithmic complexity is just a factor of three compared to just a forward system simulation. Numerical results for both problem classes are presented. More details can be found in [1, 2, 3, 4]

REFERENCES

- [1] K. Eppler, S. Schmidt, V. Schulz, and C. Ilic, *Preconditioning the Pressure Tracking in Fluid Dynamics by Shape Hessian Information*, Journal of Optimization Theory and Applications, 141 (2009), pp. 513–531.
- [2] S. Schmidt, V. Schulz, Shape derivatives for general objective functions and the incompressible Navier–Stokes equations, Control and Cybernetics, Vol. 39, 2010, pp.677-713.
- [3] S. Schmidt, V. Schulz, Impulse response approximations of discrete shape Hessians with application in CFD, SIAM Journal on Control and Optimization 48 (4) (2009) 2562–2580.
- [4] S. Schmidt, V. Schulz, C. Ilic, and N. R. Gauger. *Three Dimensional Large Scale Aerodynamic Shape Optimization based on Shape Calculus*, submitted to AIAA Journal, 2011

Beyond classical saddle point theory

BARBARA WOHLMUTH

(joint work with Markus Melenk, Christian Wieners)

In this presentation, we consider two different primal-dual finite element formulations. The first one results in a surface based equality saddle point problem and is associated with the discretization of a standard second order elliptic PDE. The discrete dual variable stands for the flux at the boundary and possibly at inner interfaces. It can be easily computed from the discrete primal variable in a post-process. Then the abstract framework of saddle point problem guarantees error estimates for both the primal and dual variables, e.g., [1, 4]. These a priori results are obtained simultaneously and thus only suboptimal upper bounds for the dual variable are reached. Coercivity, continuity and uniform inf-sup stability are the key ingredients in the proof. Here we show quasi-optimal a priori convergence results in the L^2 - and the $H^{-\frac{1}{2}}$ -norm for the approximation of surface based Lagrange multipliers, see [3]. Using anisotropic norms in the primal variable

an additional factor $\sqrt{h}|\ln h|$ in the a priori bound for the dual variable can be recovered. Of crucial importance are new estimates in strips of width $\mathcal{O}(h)$. The second formulation under consideration is associated with a non-local model in plasticity. Classical plasticity models do not take into account length scale effects and are not in agreement with microscopic experiments. Thus there is a need for non-local plasticity models, see [2] for an overview, e.g., involving the curl operator. Here we end up with a volume based inequality primal-dual setting for the displacement, plastic variable and the back stress. Although, we have to face a variational inequality, we obtain optimal low order a priori results, [6]. A L^2 -lifting of the conjugate plastic variable yields a local flow rule, and thus the application of a locally defined radial return algorithm is feasible. These techniques can also be applied to single-crystal strain-gradient plasticity models, see [5].

REFERENCES

- [1] F. Brezzi, M. Fortin, *Mixed and hybrid finite element methods*, Springer, New York, 1991.
- [2] M. Gurtin, E. Fried and L. Anand, *The mechanics and thermodynamics of continua*, Cambridge University Press, 2010
- [3] M. Melenk and B. Wohlmuth, *Quasi-optimal approximation of surface based Lagrange multipliers in finite element methods*, TU Wien ASC Report **13** (2011).
- [4] R. Nicolaides, *Existence, uniqueness and approximation for generalized saddle point problems*, SIAM J. Numer. Anal. **19** (1982), 349–357.
- [5] D. Reddy, C. Wieners and B. Wohlmuth, *Finite element analysis and algorithms for single-crystal strain-gradient plasticity*, KIT IWRMM Preprint **04** (2011).
- [6] C. Wieners and B. Wohlmuth, *A primal-dual finite element approximation for a non-local model in plasticity*, SIAM J. Numer. Anal. **49** (2011), 692–710.

Advances in Domain Decomposition Algorithms for $\mathbf{H}(\text{curl})$ Problems

OLOF B. WIDLUND

(joint work with Clark R. Dohrmann)

We consider a variational problem, which is positive definite and self-adjoint: Find $\mathbf{u} \in H_0(\text{curl}; \Omega)$ such that

$$a(\mathbf{u}, \mathbf{v})_\Omega = (\mathbf{f}, \mathbf{v})_\Omega \quad \forall \mathbf{v} \in H_0(\text{curl}; \Omega),$$

where

$$(1) \quad a(\mathbf{u}, \mathbf{v})_\Omega := \int_\Omega [\alpha \nabla \times \mathbf{u} \nabla \times \mathbf{v} + \beta \mathbf{u} \cdot \mathbf{v}] dx, \quad (\mathbf{f}, \mathbf{v})_\Omega = \int_\Omega \mathbf{f} \cdot \mathbf{v} dx.$$

Note that $\|\mathbf{u}\|_{H(\text{curl}; \Omega)}^2 = a(\mathbf{u}, \mathbf{u})$ for $\alpha = \beta = 1$. We use an essentially boundary condition, i.e., the tangential component of \mathbf{u} vanishes on $\partial\Omega$.

We can rewrite the problem, for positive, piecewise constant coefficients, as

$$a(\mathbf{u}, \mathbf{v})_\Omega = \sum_{i=1}^N (\alpha_i (\nabla \times \mathbf{u}, \nabla \times \mathbf{v})_{\Omega_i} + \beta_i (\mathbf{u}, \mathbf{v})_{\Omega_i}).$$

Here $\{\Omega_i\}$ is a decomposition of Ω into possibly many subdomains. Our domain decomposition algorithms are defined in terms of local solvers on these subdomains or the unions of pairs of subdomains, which share a subdomain edge, in two dimensions, or a subdomain face, in three dimensions, and one or two coarse problems which account for global transport of information in each iteration.

There are two relevant finite element spaces $W_{\text{curl}}^{h_i}$ of lowest order triangular Nédélec elements and $W_{\text{grad}}^{h_i}$ of standard piecewise linear continuous elements, on the same triangulation. The Nédélec elements are $H(\mathbf{curl})$ -conforming with constant tangential components on each edge of the triangulation and with these values common across each edge.

A key to our work is, with Π^{h_i} the interpolant into the Nédélec space: For any $\mathbf{u}_h \in W_{\text{curl}}^{h_i}$, there exist $\Psi_h \in (W_{\text{grad}}^{h_i})^d$, $p_h \in W_{\text{grad}}^{h_i}$, and $q_h \in W_{\text{curl}}^{h_i}$, such that

$$\begin{aligned} \mathbf{u}_h &= \mathbf{q}_h + \Pi^{h_i}(\Psi_h) + \nabla p_h, \\ \|\nabla p_h\|_{L^2(\mathcal{D})}^2 &\leq C \left(\|\mathbf{u}_h\|_{L^2(\mathcal{D})}^2 + H^2 \|\nabla \times \mathbf{u}_h\|_{L^2(\mathcal{D})}^2 \right), \\ \|h^{-1} \mathbf{q}_h\|_{L^2(\mathcal{D})}^2 + \|\Psi_h\|_{H(\text{grad}, \mathcal{D})}^2 &\leq C \|\nabla \times \mathbf{u}_h\|_{L^2(\mathcal{D})}^2. \end{aligned}$$

This result is essentially borrowed from Hiptmair, Xu, and Zou. It is also central in their work on algebraic multigrid and other algorithms for $H(\mathbf{curl})$ and $H(\text{div})$; see e.g., Hiptmair and Xu [3]. With this representation, which is valid for non-convex domains, we can then attempt to use our previous experience in designing and analyzing domain decomposition algorithms for problems posed in $W_{\text{grad}}^{h_i}$.

There are so far three subprojects. In the first, two-dimensional problems were considered for quite general subdomains, which are not necessarily Lipschitz but only *uniform*; see [1]. The condition number bound for the preconditioned operators is essentially of the form $C(1 + \log(H/h))^2$, with C a constant independent of the number of subdomains, their diameters, and the dimension of the local subdomain problems and with H/h the maximum number of elements across any subdomain.

For three dimensions, we have considered BDDC algorithms using the same primal constraints as in Toselli [5]. In the most interesting variant there are two primal constraints per subdomain edge; the number of such constraints is effectively the dimension of the coarse space of the preconditioner. We have been able to improve Toselli's result and we can also relax his conditions on the coefficients α_i and β_i . Some of our results are described in [2]. We note that Toselli considered FETI-DP algorithms while we have worked on BDDC. However, both his and our results are valid for both families of domain decomposition algorithms since there is a very close connection of the relevant spectra for any pair of FETI-DP and BDDC algorithms with the same sets of primal constraints.

In addition, we have reexamined early, very interesting work by Hu and Zou [4]. Their algorithm has two coarse problems which resemble those of classical *wire-basket-based* domain decomposition algorithms. We have been able to improve

their basic bound to $C(1 + \log(H/h))^2$ and also shown how the coarse problems of the algorithm can be implemented effectively.

REFERENCES

- [1] C. Dohrmann and O. Widlund, *An Iterative Substructuring Algorithm for Two-dimensional Problems in $H(\text{curl})$* Department of Computer Science, Courant Institute technical report **936** (2010).
- [2] C. Dohrmann and O. Widlund, *Some recent tools and a BDDC algorithm for 3D problems in $H(\text{curl})$* , Proceedings of the 20th International Conference on Domain Decomposition, submitted (2011).
- [3] R. Hiptmair and J. Zou, *Nodal auxiliary space preconditioning in $H(\text{curl})$ and $H(\text{div})$ spaces*, SIAM J. Numer. Anal. **45** (2007), 2483–2509.
- [4] Q. Hu and J. Zou, *A nonoverlapping domain decomposition method for Maxwell's equations in three dimensions*, SIAM J. Numer. Anal. **41** (2003), 1682–1708.
- [5] A. Toselli, *Dual-primal FETI algorithms for edge finite-element approximations in 3D*, IMA J. Numer. Anal. **26** 2006, 96–130.