

Coexistence of Multiple HomePlug AV Logical Networks: A Measurement Based Study

Zhang Liu, Alaeddine El Fawal and Jean-Yves Le Boudec
Laboratory for Communications and Applications (LCA), EPFL, Switzerland
{zhang.liu, alaeddine.elfawal, jean-yves.leboudec}@epfl.ch

Abstract—HomePlug AV (HPAV) was designed to provide high speed in-home communication with 200Mbps PHY rate, with the goal to overcome various noises over power wires and to jump from one phase to a neighboring one. A HomePlug AV Logical Networks (AVLN) is defined by cryptographic means, i.e. stations that share the same key and hear each other are in the same AVLN; however, AVLNs which coexist in a neighborhood cannot communicate but share the same physical layer. These points imply that people using HomePlug AV may share system throughput with neighbors without being aware of it. In order to assess the reality of this potential problem, we performed measurements on an experimental testbed with several AVLNs and equipment from different manufacturers. Our results are: 1. we verified that HomePlug AV stations can communicate even over physically separated wires, and thus neighboring stations in the same AVLN or in different AVLNs may share the same throughput; 2. when stations are placed in two different AVLNs, system performance is noticeably less compared to having the same stations at the same locations but in one single AVLN; 3. HPAV stations from different manufacturers do interoperate but experience heavy per-pair throughput outages. Our findings suggest that HPAV does not perform satisfactorily in large deployments. A possible solution to the problem would be to make different AVLNs quasi-orthogonal at the physical layer, perhaps using the cryptographic key to seed an OFDM hopping sequence.

Keywords- Homeplug AV; multiple networks coexistence; experimental measurements

I. INTRODUCTION

Homeplug AV (HPAV) is a power line communication (PLC) technology developed by the Homeplug alliance [1]. It provides 200Mbps of physical rate by using frequencies from 2MHz to 28MHz [2]. HPAV was designed to offer broadband communication for in-home applications, overcome various noises over power wires and jump from one phase to a neighboring one. It has advantages over conventional Ethernet and Wi-Fi: no new wiring is needed and there is much less fading. A HomePlug AV Logical Network (AVLN) is defined by a cryptographic key, called the Network Membership Key (NMK): all stations that can hear each other and share the same NMK are in the same AVLN. Typically, it is assumed that one household uses one NMK and neighboring households use different NMKs. Stations that can hear each other but do not have the same NMK are not in the same AVLN and cannot communicate at layer 2. However, they share the same physical layer and are in the same collision domain.

As a consequence, in a neighborhood where some power wires among neighbors are heavily coupled (e.g. are physically closed on some portion of the wiring system, perhaps in the same conduit), distinct AVLNs owned by distinct households may form a shared medium, in which case there will be channel contention among stations belonging to different AVLNs. If there is only one home using HPAV, performance might be fine; but as a neighbor starts using HPAV, performance might degrade and applications using HPAV such as Video Streaming might suffer.

Previous works on performance of HomePlug AV were mainly focused on contention in CSMA region with no respect to the numbers of AVLNs in the shared medium. Reference [3] studied methods of optimizing back off procedure to improve system throughput. For multiple HPAV networks, Inter-PHY Protocol (IPP) [4] offers opportunity to transfer information among different networks and achieves time re-use among them. [5] and [6] mentioned protocols to co-operate PLC access network with in-home network to achieve channel re-use and fairness.

As PLC technology becomes more and more popular, this topic of coexistence and performance of Multiple AVLNs in neighborhood environment is getting more attention. But it is hard to find field test data about this topic in public domain. In order to assess whether the potential problem mentioned earlier is real, we created an evaluation testbed and performed a series of experiments and measurements.

Our findings are: 1. we verified that, as expected, HomePlug AV stations can communicate on different phases and even unsynchronized close wires, and thus neighboring stations in the same AVLN or in different AVLNs share the same medium and consequently the same total system throughput; 2. however, when stations are placed in two different AVLNs, system performance is noticeably less compared to having the same stations at the same locations but in one single AVLN; 3. HPAV stations from different manufacturers do interoperate but experience performance degradation: when stations from different manufacturers are used in multiple AVLNs, the system throughput is at the same level but per-pair throughput outages are heavier compared to stations from the same manufacturer. Further, stations that support a non standard higher rate of 1Gbps are forced to revert to the lower, standard rate of 200Mbps, as soon as one station exists in the neighborhood that does not support this higher rate, even if the latter station is in a different AVLN.

The rest of the paper is organized as follows. Section II describes background information and assumptions. Section III contains the detailed descriptions about our material and methods. Section IV describes our experiments and findings. In Section V we draw a few tentative conclusions.

II. HOW MULTIPLE AVLNS WORK

In multiple AVLNs environment, each AVLN is a group of HPAV stations that can communicate with each other at the MAC layer. These HPAV stations also share the same NMK, which is used to encrypt the data and distinguish other HPAV stations in other AVLNs. In each AVLN, one HPAV station acts as a central coordinator (CCo), which responds to broadcast periodical beacon message and manages other stations.

HPAV uses a beacon based scheme as shown in Figure 1 below. The beacon period is divided into 3 regions. The Beacon region accompanies beacons broadcasted by CCo from every AVLN. The CSMA region accompanies non-persistent traffic from all stations of all AVLNs, the detailed CSMA protocol will be shown later in this section. The Contention-Free region accompanies persistent traffic with QoS requirements. Most commercial HPAV products have no interface to support QoS requirement, so currently all traffic is happening in the CSMA region, regardless of which AVLN they belong to.

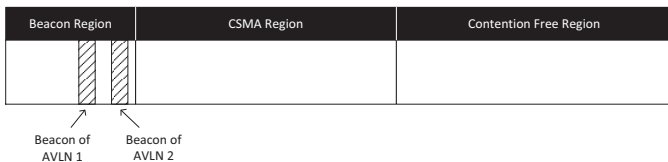

Figure 1. Beacon period of HPAV signal.

HPAV uses a CSMA/CA MAC protocol similar to the one in 802.11, but with some differences. Other than RTS/CTS used in 802.11, HPAV use priority resolution slots PRS0 and PRS1 to determine which station can access the medium. The two priority resolution slots provide 4 priority levels. If a HPAV station senses the medium is busy in the PRS, it knows there is a HPAV station with higher priority to transmit, thus it does not go into contention state. Multiple HPAV stations at the same highest priority will go for contention state, and the one that will transmit is the one whose backoff counter first reaches 0. In practice, most end systems have no support for priority differentiation, and all user traffic is at the same priority level. Figure 2 shows an example of how CSMA/CA works for HPAV with 2 HPAV stations that want to transmit on the medium.

The Beacon period starts after the power phase crosses 0 with a small offset, and lasts for 2 power cycles. Multiple AVLNs will result in multiple beacons, if they are all on the same phase, they will all be accommodated together in the beacon region. Note that if they are placed on different phases, whether they will still be accommodated together or have 120 degree shift is not revealed by the HomePlug Alliance.

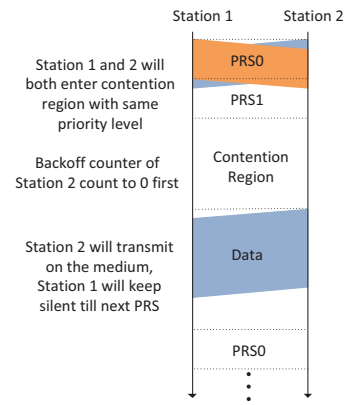

Figure 2. Two HPAV stations contending for the medium. Both go for priority resolution first, then backoff counter of Station 2 counts down to 0 first, Station 2 transmits on the channel, Station 1 keeps silent till next PRS.

III. MATERIAL AND METHODS

A. Hardware and Software

We used a total of 8 HPAV products, 4 Devolo dLan 200 AV and 4 Belkin Gigabit Powerline HD. Devolo stations are standard HPAV products which use a chip from Intellon; Belkin stations use a chip from Gigles which provides 1Gbps capability plus backward compatibility with the HPAV standard. Both products are certified by HomePlug Alliance. 4 laptops running Debian OS are used in our measurements; the throughput measurement software is Iperf 2.0.2.

B. Performance Metrics

In our field measurement, each HPAV station maintains a UDP flow to another HPAV station and tries to achieve maximal throughput by using the Iperf software. We are using the following performance metrics.

- **System throughput** is the total throughput of all stations in the shared medium. This metric is used to measure how well multiple AVLNs coexist; the better they coexist, the higher the system throughput is.
- **Per-pair throughput** is the rate of successful messages delivered between two stations. **Per-pair receiving throughput** is the rate of successful message received by one station. This metric is used to measure the performance for individual HPAV station and station pairs in term of availability for applications.
- **Logical-network throughput** is the total throughput of all stations in one AVLN. This metric is used to measure the overall performance of HPAV in one home.

C. Environments of Experiments

We set up two experimental environments, as shown in Figure 3. The first one is the **isolated power environment**. In this environment, a power wire network is built by 1.5m of unshielded wires connected to power sources that are built by DC/AC convertor and battery sets which generate power at

220V/50Hz. HPAV stations are placed at both ends of each wire. This environment is used to measure the coupling effect of HPAV signal and the ideal throughput with no additional noise introduced. The second one is **3-phase power environment**. In this environment we have several 220V/50Hz power sockets connect to 3 phases of a 3-phase 380V power supply from the power grid of our university. HPAV stations are placed close to each other on each phase. This environment is used to simulate the power wire network of a dwelling area containing several neighbors.

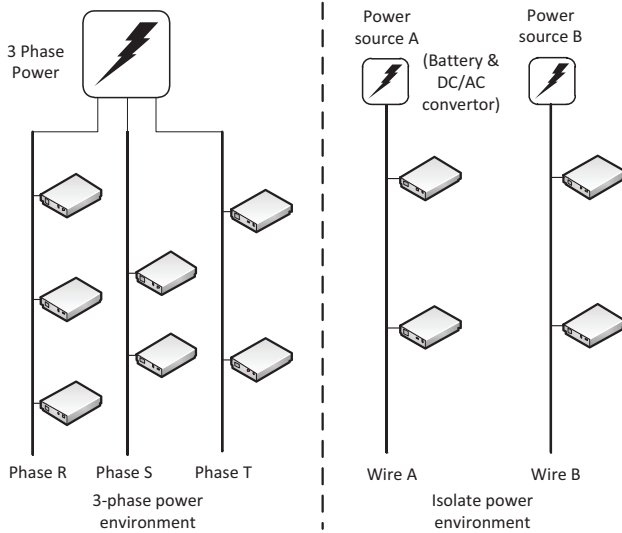

Figure 3. Two environments used in experiments

IV. FIELD MEASUREMENTS AND FINDINGS

A. *HPAV works with different phases and even separate unsynchronised wires, the shared medium for HPAV will cover a large area.*

HPAV were originally designed to communicate across phases by taking advantage of the nature of power wire coupling. The first experiment is designed to examine the maximal achievable system throughput in 5 different setups including single wire, single phase, cross phases, cross twisted wires and cross wires that are 20cm away. The first and the last two setups use the isolated power environment, the rest use the 3-phase power environment. In order to achieve maximal throughput, 2 or 4 Devolo HPAV stations are set in one AVLN, 1 or 2 pairs of bi-directional communication are carried out for each setup as is shown in Figure 4 together with the measured maximal system throughput.

From the measurement results we can see that the highest system throughput of 87.8Mbps was achieved with the single wire setup. Single phase and cross phase setups have almost the same performance which are 74.5Mbps and 74.0Mbps respectively; this verifies that HPAV works across phases. In the last two setups, HPAV even managed to work with separated unsynchronised wires, and achieved throughput of 40.3Mbps for twisted wires and 20.5Mbps for wires 20cm away from each other. The results confirm the expected ability of HPAV to propagate to neighboring wires.

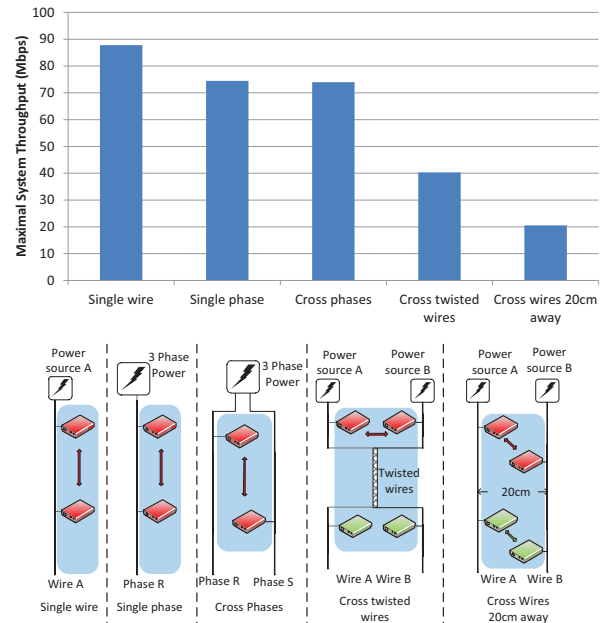

Figure 4. Top: Maximal system throughput for HPAV achieved in 5 different setups are shown. Bottom: 5 setups with 1 or 2 pairs of bi-directional communications carried out by 2 or 4 Devolo HPAV stations in same AVLN.

B. *System Throughput Decreases with Same Amount of HPAV Stations in Multiple AVLNs Rather than One AVLN*

This experiment was designed to examine the impact of multiple AVLNs on system throughput. Measurements are carried out in 2 setups which all use the 3-phase power environment. 4 Devolo HPAV stations are placed in one or two AVLNs on two phases. The results are shown in Figure 5 along with the detailed setups.

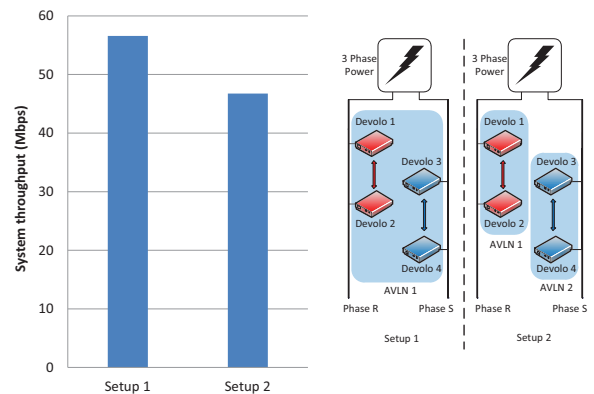

Figure 5. Left: System throughput comparison with 2 setups. Right: Setup 1: 4 HPAV stations in 1 AVLN on 2 phases. Setup 2: 4 HPAV stations in 2 AVLNs on 2 phases.

Due to contentions, setup 1 achieved throughput of 58.6Mbps. Setup 2 achieved 46.2Mbps under the same contention of 4 HPAV stations over the same medium. So splitting the AVLN into two over 2 phases caused a throughput decrease of about 20%.

C. Per-pair Throughput Outages Occur with Multiple AVLNs

This experiment was designed to examine the impact of multiple AVLNs to the per-pair receiving throughput of individual HPAV stations. Measurements are carried out with 2 pairs of bi-directional communications over 4 Devolo HPAV stations, which are all on the same AVLN. Figure 6 shows the measured per-pair receiving throughputs.

The results indicate that multiple AVLNs placed on different phases may result in throughput outages on individual HPAV stations. This issue is not observed if only one AVLN is used. The outages are not very frequent, but would affect real-time applications such as videoconferencing or even low rate real time applications such as IP telephony, since during the outage the flow of data is completely interrupted and the outage lasts for several second.

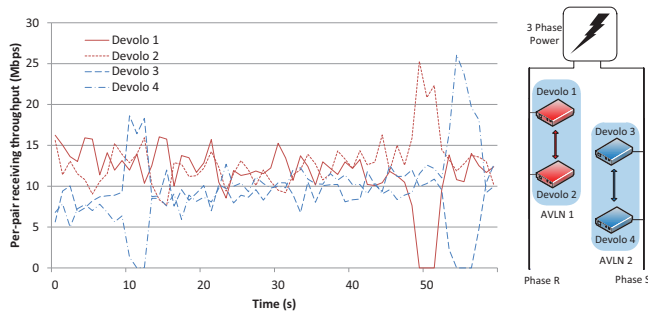

Figure 6. Per-pair receiving throughputs of 4 HPAV stations with setup shown to the right: 2 pairs of bi-directional communications carried out by 4 Devolo HPAV stations placed in 2 AVLNs.

D. Compatibility Issues Between Different Manufacturers:

In principle, HPAV stations from different manufacturers should work flawlessly with each other since they all carry the HPAV certification from the HomePlug Alliance. But in reality compatibility issues still happen and we record them using our experiments. In the following experiments 2 Devolo and 2 Belkin HPAV stations are used together.

1) *High throughput standard HPAV stations are forced to work at low throughput if a low throughput standard HPAV Stations operates nearby:*

The Belkin Gigabit Powerline HD HPAV stations aim to offer higher throughput than HPAV standard. The following experiment shows how the logical-network throughput of an AVLN using Belkin HPAV stations was affected by a single Devolo HPAV station in another AVLN. Figure 7 below include the measurement and setup.

The measurement shows that the Belkin HPAV stations are forced to work at the standard HPAV throughput level if there is a Devolo HPAV station in the shared medium, even if the Devolo HPAV station is in another AVLN. The logical-network throughput of AVLN 1 does not recover after the Devolo HPAV station is removed, unless we unplug and re-plug the Belkin HPAV stations. This is a worrying side effect of the ability of HPAV to jump across wires: the fact that one's

neighbor starts using a Devolo adapter might force one's adapters to revert to a lower modulation rate (from 1Gbps down to 200Mbps).

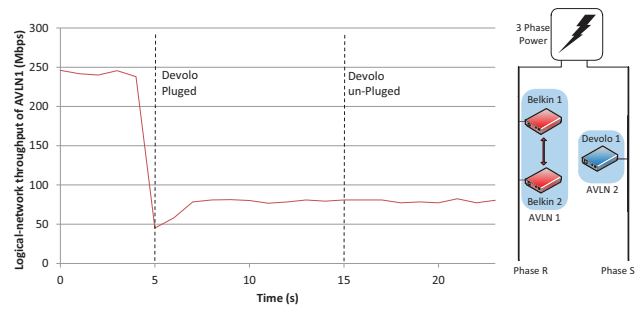

Figure 7. Logical-network throughput of AVLN 1 using Belkin HPAV stations. Measurement starts at $t=0s$, at $t=5s$ a single Devolo HPAV station is set to AVLN 2 and plugged on phase S, at $t=15s$ the Devolo HPAV station is removed.

2) More frequent per-pair throughput outages occur with multiple AVLNs

If Belkin HPAV stations are used in one AVLN on one phase, Devolo HPAV stations are used in another AVLN on another phase, the per-pair throughput outages happens more frequently, as is shown in Figure 8.

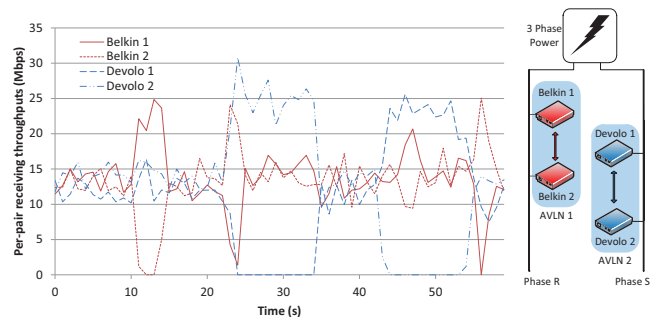

Figure 8. Per-pair receiving throughputs of 4 HPAV stations with setup shown to the right: 2 pairs of bi-directional communications carried out by 2 Belkin HPAV stations in AVLN 1 and 2 Devolo HPAV stations in AVLN 2.

Heavy throughput outages can be observed from the result above, which will heavily affect real-time applications. This issue might be caused by design or implementation incompatibilities between the two manufacturers.

E. Other results

1) *Loss of CCo will result in throughput outage of ca. 10 seconds.*

This experiment examines what happens to the HPAV stations if the CCo suddenly disappears. Four Devolo HPAV stations are used in 3-phase power environment. Devolo 1, 2, 3 and 4 are set in same AVLN, Devolo 1 and 2 are first plugged on wire, according to specification [2], CCo of AVLN 1 is either Devolo 1 or Devolo 2. Then Devolo 3 and 4 are plugged on wire and start bi-directional communication. Figure 9 shows the measurement result with setup detail. The result shows that

loss of CCo takes 10s to affect the system throughput of the AVLN, and another 10s to recover.

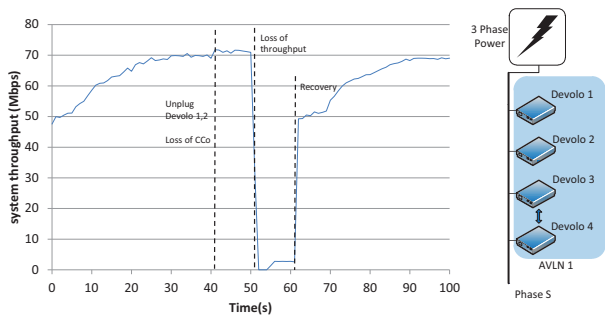

Figure 9. Devolo 3 and 4 started bi-directional communication at $t=0s$, at $t=41s$ Devolo 1 and 2 are removed, thus the CCo is lost. At $t=51s$ the throughput is decreased to 0, and then recovered at $t=61s$.

2) No throughput anomaly in HPAV

The throughput anomaly in 802.11b is a phenomenon by which a station with a low modulation rate imposes a low throughput to all stations [9]. In this last experiment, we verified that there is no throughput anomaly in HPAV. The measurement and setup are shown in Figure 10 below. The reason that HPAV does not have throughput anomaly is because the maximum length of PHY frame of HPAV is limited to 160 OFDM symbols, which is fixed in time, thus low rate frame will not possess the medium longer than this time.

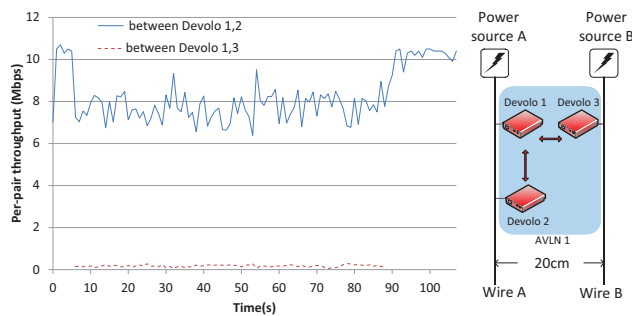

Figure 10. Left: throughput of bad link only affect the good link by 20%, no throughput anomaly observed. Right: 3 Devolo HPAV stations are set in 1 AVLN, Devolo 1,2 on wire A, Devolo 3 on wire B, bi-directional communication between Devolo 1,2 and Devolo 1,3 are maintained.

V. CONCLUSION

We investigated the performance of multiple AVLNs in neighborhood by experimental measurements and found that the ability of HPAV to cross wires does come at a price, namely a possible hidden dependency of one AVLN on another one.

It would be possible to avoid the problem. In the rest of this conclusion we describe a possible initial idea to achieve this goal. The problem stems from the fact that different AVLNs are in the same collision domain. Now it is known in other

settings that it might be better to treat interfering signals as noise rather than avoid interference entirely using MAC protocols [7, 8]. The idea would be now to assign a mutual exclusion domain to each AVLN. Within an AVLN one HPAV station can transmit at a time and HPAV stations outside the AVLN could transmit simultaneously. Since the bandwidth of the system is limited, stations outside the AVLN do interfere, but if proper randomization of signal is performed, it should be possible to treat interfering AVLN as noise.

This would be particularly possible if quasi-orthogonal FDMA is used. Each AVLN selects a frequency hopping sequences that is quasi-orthogonal to other AVLNs. The hopping sequence could be derived from the NMK, thus achieving a one-to-one mapping between AVLN and mutual exclusion domain. Figures 11 shows an example of 2 AVLNs accessing the channel simultaneously. A detailed performance analysis of such a scheme will be the topic of future research.

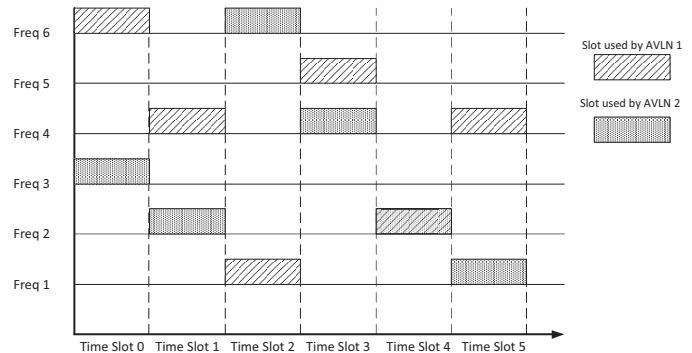

Figure 11. AVLN 1 and 2 access the channel simultaneously, collisions happen with low probability.

REFERENCES

- [1] Homeplug Powerline Alliance, <http://www.homeplug.org>
- [2] HomeplugAV White Paper, 2005, Homeplug Powerline Alliance, Inc.
- [3] S.-G. Yoon, J. Yun, and S. Bahk, "Adaptive Contention Window Mechanism for Enhancing Throughput in HomePlug AV Networks" in Proc. of *IEEE CCNC*, Las Vegas, USA, Jan 2008.
- [4] S. Galli, A. Kurobe, and M. Ohura, "The Inter-PHY Protocol (IPP): A Simple Co-Existence Protocol," in Proc. of *IEEE ISPLC*, Dresden, Germany, Mar. 29–Apr. 1, 2009.
- [5] L. P. Do, R. Lehnert, "Distributed Dynamic Resource Allocation for Multi-Cell PLC Networks" in Proc. of *IEEE ISPLC*, Dresden, Germany, Mar. 29, 2009.
- [6] L. P. Do, R. Lehnert, "A Channel Self-Organizing Protocol Supporting for Coexistence of Access and In-Home PLC Systems" in Proc. of *IEEE ISPLC*, Rio de Janeiro, Brazil, March, 2010.
- [7] B. Radunovic and J.-Y. Le Boudec, "Optimal Power Control, Scheduling, and Routing in UWB Networks" *Journal on Selected Areas in Communications*, 2(7), 2004.
- [8] S.-G. Yoon, D. Kang and S. Bahk, "OFDMA CSMA/CA protocol for power line communication" in Proc. Of *IEEE ISPLC*, Rio de Janeiro, Brazil, March, 2010
- [9] Heusse, M.; Rousseau, F.; Berger-Sabbatel, G and Duda, A. "Performance anomaly of 802.11 b", In Proc. Of *Infocom 2003*, March-April 2003.