

Ambush avoidance in vehicle routing for valuable delivery

Peter Goodings Swartz * Gaëtan Duyckaerts *
Matteo Salani *

December 16, 2009

Report TRANSP-OR 091216
Transport and Mobility Laboratory
Ecole Polytechnique Fédérale de Lausanne
`transp-or.epfl.ch`

*Transp-OR, Ecole Polytechnique Fédérale de Lausanne, CH-1015 Lausanne, Switzerland, peter.goodings.swartz@gmail.com

Abstract

In this work we consider route planning for valuable delivery in an urban environment under the threat of ambushes in which a vehicle, starting from a depot, has to serve a set of predetermined destinations during the day. We provide a method to plan for hardly predictable multi-destination routing extending a minmax flow-based model available for single-destination cases. We then formulate the process of selecting a visiting order as a game to obtain a mixed routing strategy. We analyse the application of the method to a set of simulation scenarios and compare the mixed routing strategy against the best routing. Finally we develop further the methodology introducing a second-level optimization model which reduces the overall risk associated to the proposed mixed routing strategy.

1 Introduction

Vehicle ambush avoidance in urban environments is crucial to both peacetime and war-time goals. Unsafe routing prejudices successful humanitarian shipments through troubled areas with a history of hijacking, diplomatic security for high-profile VIPs, valuable transfers between banks, and military-supply transport through insurgency zones. In this article, we develop a program that can plan optimal routes for an un-escorted vehicle carrying out multiple stops under threat of ambush. Possible applications of this work include all such physical situations, as well as, possibly, data-routing on the internet. For this article, we consider the case of an armored vehicle carrying a sum of money for deposit at one or more banks in a relatively stable urban situation, in other words, an environment in which planning is required for ambushes. At its base, the problem is a Vehicle Routing Problem (VRP), see e.g. Toth and Vigo (2001). However, the problem is complicated substantially by the fact that it is both deterministic and stochastic in nature. The vehicle must visit one or more fixed locations, in a manner similar to the traveling salesman, while taking routes that prevent an ambusher from predicting the vehicles path, a stochastic measure. The attacker can be modeled as a feature of the environment, as is the case in adaptations of hazmat-transport literature, or the attacker's incentives can be rigorously modeled, as is the case in game-theoretic modeling of ambush.

Erkut and Verter (1998) and List et al. (1991) are seminal reviews of hazmat literature. A trend of such literature is modeling risk as an accumulating metric over the course of a vehicle's route. This type of metric makes sense for a hazmat vehicle, as such a vehicle is faced by a small risk of accident for every differential distance of environment traversed. Integrating this accumulating differential risk is thus one method to determine total risk of a hazmat vehicle's path.

Direct adaption of this metric effectively posits that there are attackers in every differential portion of the environment and that the longer a vehicle travels, the more risk it encounters. This hypothesis may be valid in war zones or in cases of extreme insurgency. However, our hypothesis of a

relatively-stable urban environment means that such a direct application of hazmat literature is not the best option. In our urban situation, a more realistic modeling of the robber should be based upon the idea of prepared ambush that activates if the vehicle passes the prepared point.

Hazmat literature also proposes algorithms for creation of dissimilar routes, the priority of the stochastic portion of our model. In hazmat-literature, the goal of these routes is equal risk sharing among communities, as is presented in Carotenuto et al. (2007). For the purposes of ambush games, however, such routing methods are not ideal. We are not faced with the necessity of choosing dissimilar routes that distribute risk across communities, but rather with the need to implement a routing system without optimal ambush points. Hazmat based predictability metrics are in fact predictable, and thus we eliminate hazmat-based predictability models of fund transfer.

Likhachev and Stentz (2007) models the attacker as possible barriers in an environment, detectable by a vehicle with sensors which can reroute dynamically. The robber is thus a part of the environment, as opposed to an autonomous actor. For our vehicle, posited without sensors and located in a relatively stable urban-environment, this is a less interesting prospect.

The game-theoretic alternative models the vehicle and attacker as members of a 2-player non-cooperative game. Such a game, in its most basic form, involves the crossing of a continuous interval in which an attacker can place ambushes, as in Ruckle (1983) and Zoroa et al. (1999).

For games played on a discontinuous interval, i.e., a road network, modeling is driven by the solution method envisioned. If the problem is to be solved by a path-based method, dynamic solution is necessary. Any route vs. ambush-site matrix would quickly explode for a non-trivial road network.

Dynamic solutions are thus proposed by Bell (2004), Gentry and Feron (2004), and Root et al. (2005). These methods are attractive, but do depend upon high-network connectivity to achieve good results.

An alternative is exact flow-based solution as proposed by Joseph (2005). This method calculates a mixed strategy for the vehicle by equilibrating flows across a matrix in function of the risks at each node. This method

avoids the obstacles to exact solution presented by the route-based method, and thus allows networks of large size to be solved exactly. We thus, after reviewing the literature, modeled the problem with the use of this flow-based solution in mind.

2 Model

We model a situation in which a travelling salesman can operate in an environment of risk, visiting multiple locations without returning to the depot. This method will be useful for any resupply vehicle operating in a dangerous environment.

Let V be the set of nodes which model possible attack sites (road lengths or crossroads), as well as bank sites, $B \subseteq V$ (where danger of attack equals zero), and the depot $d \in V$. These nodes are joined by road links modeled by set E , which are bi-directional edges.

We make the following assumptions:

- Both players are assumed to have complete information on the network, including full data on ambush risk at each node.
- Ambush sites and vehicle paths are chosen before the vehicle departs from the depot, and these decisions are not changeable post-departure.
- Ambushes take place only at nodes.
- The probability of ambush success at the depot or at a bank is equal to zero.
- The robber is intelligent, and will maximize payoff.
- The robber has only enough resources to set up one ambush (a lonely gangster).
- The vehicle has no ability to sense ambushes before they are triggered.

Indeed, a competent transport company will certainly analyze the road network over which it must route its vehicles, assessing risk at different points on the network. A competent robber will certainly carry out a similar analysis in order to find the best ambush site. We assume both the company and the robber will be able to correctly assess ambush risk. We assume that the robber requires time to set up his ambush to have a reasonable chance of success. His game is ambush, not pursuit. The vehicle must leave from the depot and must arrive at the banks, and, thus, if an ambush could succeed with reasonable probability of success at these points, the robber would always ambush at these nodes. Secure transport companies in the Vaud area of Switzerland have indicated that attacks often take place at loading and unloading sites, which does bring into question this hypothesis. However, problems of depot and bank security are outside of the scope of a routing problem, and we assume these aspects are well managed. An intelligent robber will always set an ambush at the node with maximum payoff. Our solution in effect allows this maximum-payoff node to “shade” other nodes with non-zero but also non-maximum robber payoffs. Routes that pass through these shaded nodes are effectively not optimized as the robber will not carry out an ambush at these points.

Let α_j be the probability of success of an ambush prepared at node j and p_{ij} the probability that a vehicle passes by the link $(i, j) \in E$. Thus, we can model the probability of a successful ambush at node j as:

$$r_j = \sum_{(i,j) \in E} (p_{ij}) \alpha_j$$

This formulation adopts itself quite well to implementation in real-world transport situations. Probability of ambush success can be based on proximity of nodes to police stations, bank security, easily blocked streets, and upon actual traffic dynamics at different times of day. The vehicle controls the frequency with which each node is used. As the robber will always plan an ambush for the node with a maximum product of these two factors, thus the maximum payoff, we can easily model the robber’s behavior as:

$$Z_r = \max_{j \in V} r_j$$

The goal of a route planner is thus to minimize the maximum value of this product at each node used. We consequently have a minimax problem, which, when solved, will yield no one optimal node for the robber. In the simplest case of an origin-to-one destination problem, the minimax game can be expressed as:

$$Z_p = \operatorname{argmin}_p \left\{ \max_{j \in V} \sum_{(i,j) \in E} (p_{ij}) \alpha_j \right\}$$

or equivalently as:

$$Z_p = \operatorname{argmin}_p \left\{ \max_{j \in V} r_j \right\}$$

subject to the conditions of flow conservation:

$$\sum_{i \in V} (p_{ij}) = \sum_{k \in V} (p_{jk}) \quad \forall j \in V$$

and the constraints for mandatory locations, i.e. depot and banks, and variable non negativity:

$$\begin{aligned} \sum_{i \in V} (p_{ij}) &= 1 & \forall j \in B \cup \{d\} \\ p_{ij} &\geq 0 & \forall (i,j) \in E \end{aligned}$$

As the vehicle does not carry money while returning to the depot and is thus not vulnerable to ambush, we add an artificial edge to the set E , connecting the last visited bank to the depot. Flow on this edge is set equal to 1. This setting imposes flow circulation in the network and excludes the back-to-depot trip from contribution to the objective function.

When more than one bank is to be served by the vehicle, a further level of complexity is added to the flow-based modeling of this problem, as a flow-based model does not take account of temporal considerations. A route-based model could take account of all possible orderings of banks and all

possible routings for each ordering, but this model’s matrix would quickly explode with complexity for a non-trivial network and number of banks. Thus continuing with the flow-based model, we propose the following two-step routing system to avoid predictability:

- The order of the banks to be visited is decided by a calculation based upon the risk of each ordering.
- The solution of the flow-based model for this routing order is thus used.

2.1 A flow based model for a given routing order

We can model the problem on a multi-layer network, each layer linked by unidirectional edges, representing the probability routing for each segment of the vehicle’s journey. Let V' be the set of nodes obtained by duplicating the original edge set V , E' the resultant edge set, B' the set of nodes in V' representing each bank in its corresponding layer ($|B'| = |B|$), and d' the node in V' representing the depot (the nodes d' and d are equivalent). Ambush success rate at node k , α_k , and the probability p_{ik} that a vehicle passes by edge (i, k) have the same meaning as above. Let B be the set of layers, corresponding to the set of banks. As ambushes at the same node j in two different layers are mutually exclusive events, we model the overall probability of a successful ambush at node j of the original network by summing all probabilities of incoming arcs of the extended network and normalizing by the number of layers as:

$$r_j = \frac{1}{|B|} \sum_B \sum_{(i,k) \in E' | k \in V' \Rightarrow j \in V} (p_{ik}) \alpha_j$$

and the objective of a route planner is the same as above:

$$Z_p = \operatorname{argmin}_p \left\{ \max_{j \in V} r_j \right\}$$

subject to flow conservation constraints and mandatory location constraints extended to the extended network (V', E') :

$$\begin{aligned}
\sum_{i \in V'} (p_{ij}) &= \sum_{k \in V'} (p_{jk}) & \forall j \in V' \\
\sum_{i \in V'} (p_{ij}) &= 1 & \forall j \in B' \cup \{d'\} \\
p_{ij} &\geq 0 & \forall (i, j) \in E'
\end{aligned}$$

Figure 1 illustrates, on the left, a 6 nodes network with a depot D at node 3 and two banks at nodes 2 and 6, and, on the right, the corresponding layered network for the journey Depot – Bank₁ – Bank₂.

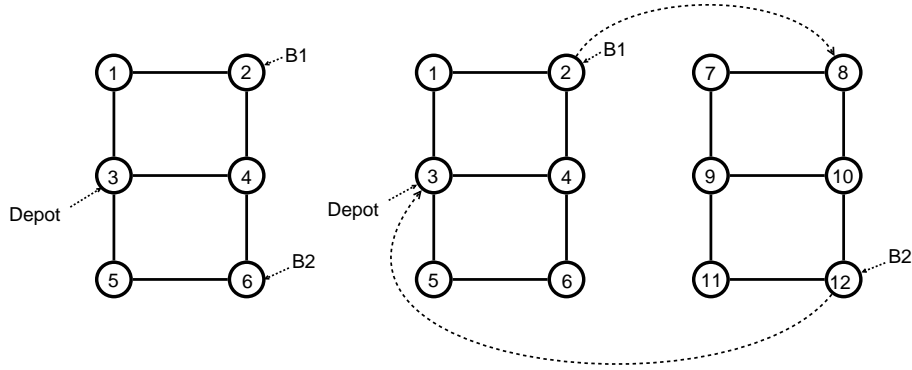

Figure 1: Small network with 2 banks. $B'=2,12$, $d' = 3$.

Furthermore, in order to eliminate sub-tours, we add a differential value that corresponds to distance $d_{i,k}$ traveled along arc $(i, k) \in V'$ when modeling the ambush success:

$$r_j = \frac{1}{|B|} \sum_B \sum_{(i,k) \in E' | k \in V' \Rightarrow j \in V} (p_{ik}) (\alpha_j + \epsilon * d_{i,k})$$

where ϵ is a small constant equal to 10^{-6} in our experiments.

2.2 Determination of the vehicle's journey

The choice of ordering, among all possible ones, is similar to a game of mixed strategies. The vehicle wishes to choose an ordering that will minimize the robber's expected payoff.

	A	B	C
A	$Z_p(A)$	$U_p(AB)$	$U_p(AC)$
B	$U_p(BA)$	$Z_p(B)$	$U_p(BC)$
C	$U_p(CA)$	$U_p(CB)$	$Z_p(C)$

Table 1: Matrix game for 3 banks orderings

If the robber does not guess correctly the vehicle's destination ordering, he stands to set up an ambush at a point by which the vehicle will not or is not likely to pass. The vehicle thus mixes strategies so as to minimize the robber's expected pay-off, and the robber attempts to maximize his payoff. Given a vehicle's journey A , the value of $Z_p(A)$ corresponds to the maximal payoff for the robber when solving the flow formulation presented in 2.1 on the layered-network. The robber receives the payoff $Z_p(A)$ if he guesses correctly the vehicle's chosen destination ordering. If he guesses incorrectly, however, he receives the payoff $U_p(AB)$, a value based upon the probability that he still has stumbled upon a node that the vehicle passes, despite his mis-estimation of the ordering, and the flow available at such a node. This situation can be summarized, for an illustrative example with three bank orderings, as reported in table 1.

$U_p(AB)$ can be estimated by:

$$U_p(AB) = \frac{\sum_{j \in V_{AB}} r_j^A}{M_B}$$

where

$$V_{AB} = V_A \cap V_B = \{j \in V \mid r_i^A > 0\} \cap \{j \in V \mid r_j^B = Z_p(B)\}$$

and

$$M_B = |V_B| = |\{j \in V \mid r_j^B = Z_p(B)\}|$$

r_j^A and r_j^B are the robber's pay-offs for the orderings A and B , respectively.

The above formulas are justified by the fact that a robber will always place himself on a node with maximum payoff in the ordering he has predicted, represented by B . We assume that, being indifferent between all nodes in this set V_B , he will choose one at random. Thus, his payoff $U_p(AB)$ can be calculated by finding the sum of payoffs for the intersection of this set with the set of all nodes that the vehicle actually traverses with positive flow, divided by the total number of ambush sites from which the robber could possibly choose M_B . The ordering game serves to reduce the robber's payoff. If the worst happens, and sets A and B are identical, the max the robber can receive will be payoff $Z_p(A)$, which is the value he would have received if the ordering game had not been played.

A mixed-strategy game thus results from this matrix, with the vehicle attempting to minimize expected robber payoff, and the robber attempting to maximize it. By the minimax theorem, for such a game in which mixed strategies are permitted, there exists a security strategy for each player, that is, a strategy which guarantees a minimum payoff. This security strategy corresponds to the optimal strategy when playing against an intelligent player. A corollary of this theorem is that each mixed security strategy corresponds to a mixed saddle point equilibrium for the game. We define here x as the vehicle's strategy, y as the robber's strategy, and π the game's payoff. By the minimax theorem, thus, for payoff matrix H :

$$\underline{\pi}(H) = \max_x \min_y x^T H y = \min_y \max_x x^T H y = \bar{\pi}(H)$$

represents the value of the saddle point. This equation can be solved by linear programming.

The size of the set of possible orderings can be seen as a drawback of the current model. However, according to our estimates, a bank car likely can visit no more than 6 to 7 banks in a day. This results in $7!$ possible orderings, or 5040 flow calculations (LP problem), and a matrix of 5040 by 5040. The calculation of the values for and the solution of the matrix are feasibly solvable by a laptop computer. Conversely, the complexity of a path-based formulation would depend also on the size and density of the network. For the same number of banks the underlying complexity follows,



Figure 2: Cambridge MA: (a) the network; (b) increasing ambush success rate with distance from banks and depot.

in the worst case, an exponential growth.

3 Application to the Cambridge's network

We illustrate the application of this method on a network based on the city of Cambridge, MA, the same network used in Joseph, 2005. As Joseph notes, this network is a good example because it is rather irregular and it is difficult to determine the optimal strategy without using a computer. The network contains 50 nodes and 91 edges (see Figure 2.a) and all edges, in our model, are bi-directional.

On the Cambridge network, we constructed 24 test scenarios consisting of 8 scenarios with 3, 4 and 5 banks each. The depot and the banks are located at nodes selected randomly on the network. Two possible alpha spreads were tested: for the first set we used random ambush success rates, and for the second the ambush success rate increased proportionally with the distance from either the depot or the banks. This increase in success models the higher security of nodes close to banks and depot, and is illustrated for a 3 bank example in Figure 2.b. In order to identify the instances,

	D-48-28-13	D-48-13-28	D-28-48-13	D-28-13-48	D-13-48-28	D-13-28-48
D-48-28-13	0.38	0.13	0.13	0.14	0.13	0.13
D-48-13-28	0.11	0.33	0.11	0.11	0.10	0.11
D-28-48-13	0.11	0.11	0.33	0.11	0.11	0.11
D-28-13-48	0.11	0.10	0.10	0.33	0.10	0.10
D-13-48-28	0.11	0.10	0.11	0.11	0.33	0.10
D-13-28-48	0.14	0.14	0.13	0.14	0.13	0.38

Table 2: Matrix game for the illustrative example - equal α

the number of banks is denoted by B_x , and the type of ambush success rate spread is denoted by R (random) or I (increasing). For example, instance B3_R_2 is the second instance tested with 3 banks and random ambush success rate.

A good example of our method’s application is the routing scheme based upon a depot at node 1 and three banks placed at nodes 13, 28, and 48. In this particular explanatory instance, two possible alpha spreads were tested. In the first, which was used only for this particular ordering example, α is equal to 0.5 throughout the network. In the second, α is determined in function of distance from depots and banks (type I) (Figure 2.b). Based upon these α configurations, we calculated the optimal routing for each possible ordering. With 3 banks, this corresponds to $3! = 6$ possible orderings. We present here the results for the ordering Depot – bank@48 – bank@28 – bank@13. For an alpha configuration of 0.5 at all attackable nodes, we find the results detailed in Figures 3.

We may interpret the obtained routing as two or three primary paths with a secondary splitting of flow. The overview shows the division of the available nodes between the different routing needs. The NW portion of the map is primarily dedicated to linking Depot – bank@48, the SE portion of the map is primarily dedicated to linking bank@48 – bank@28, and in the middle and in the NW portion we find the routes linking bank@28 – bank@13. This division of the map is in function of the position of the banks; the map is divided rationally to maximize diversionary routing while minimizing overlap of utilized areas.

The optimal ordering mix for this configuration is calculated using the following matrix (Table 2). Z values are calculated directly by our optimizations; U values are calculated as detailed above.

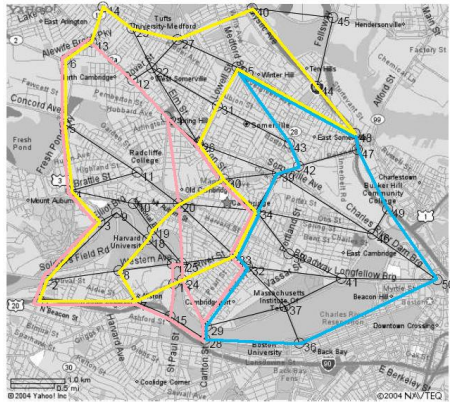

(a)

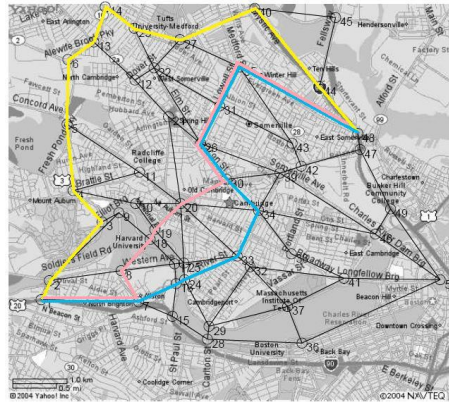

(b)

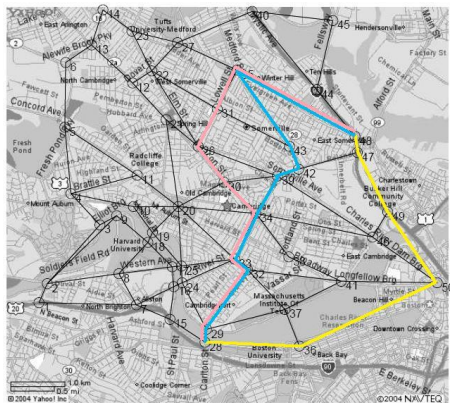

(c)

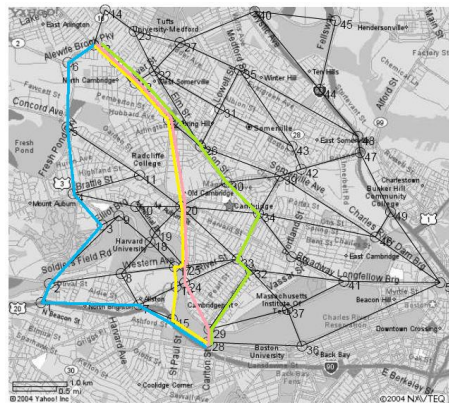

(d)

Figure 3: Constant α : (a) overview; (b) flow Depot – bank@48; (c) flow bank@48 – bank@28; (d) flow bank@28 – bank@13.

Ordering	Probability
D-48-28-13	0.0842
D-48-13-28	0.2103
D-28-48-13	0.2039
D-28-13-48	0.2178
D-13-48-28	0.2078
D-13-28-48	0.0759

Table 3: Orderings with relative probability

	D-48-28-13	D-48-13-28	D-28-48-13	D-28-13-48	D-13-48-28	D-13-28-48
D-48-28-13	0.50	0.21	0.22	0.20	0.21	0.23
D-48-13-28	0.11	0.34	0.11	0.11	0.11	0.11
D-28-48-13	0.08	0.07	0.28	0.07	0.07	0.07
D-28-13-48	0.07	0.07	0.07	0.26	0.07	0.07
D-13-48-28	0.09	0.09	0.08	0.08	0.34	0.09
D-13-28-48	0.24	0.22	0.22	0.22	0.23	0.50

Table 4: Matrix game for the illustrative example - increasing α

The optimal solution to this matrix has optimal normalized payoff 0.1534. All orderings are used in the mix, and the probability of selecting each ordering is provided in Table 3

For the same banks with α varying in function of distance from the banks and depot, the results are depicted in Figure 4.

It is interesting to note that the NW - tendency of the two routings use bank 13's security zone to their advantage. For the link bank@48 – bank@28, we see two paths in evidence, with the path hugging the SE side of the map more likely to be used. However, conclusions about the relative risks of these two paths cannot be made until the superposition of all layers is considered. An interesting interplay is seen between the desire of the bank car to stay closer to the banks and depot in order to benefit from reduced α and the desire of the bank car to maintain unpredictability by avoiding excessive overlap.

The matrix game for this second example is reported in Table 4 and the probability of selecting each ordering is provided in Table 5 with optimal normalized payoff 0.1369.

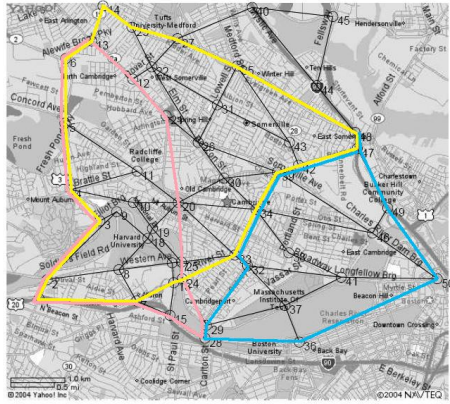

(a)

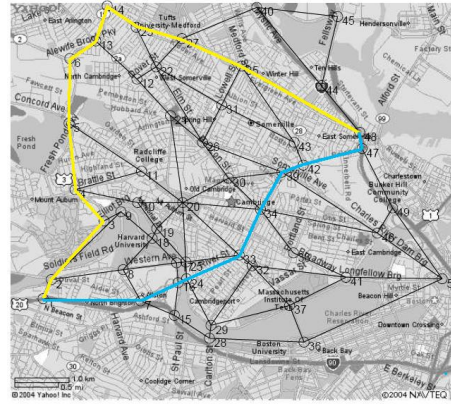

(b)

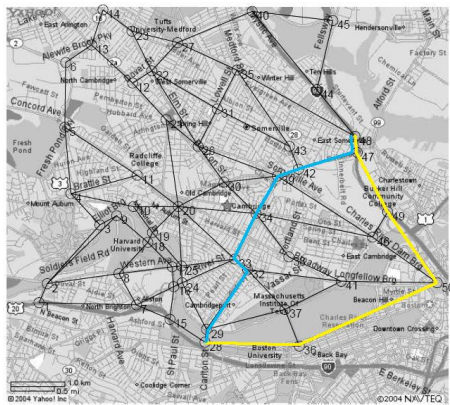

(c)

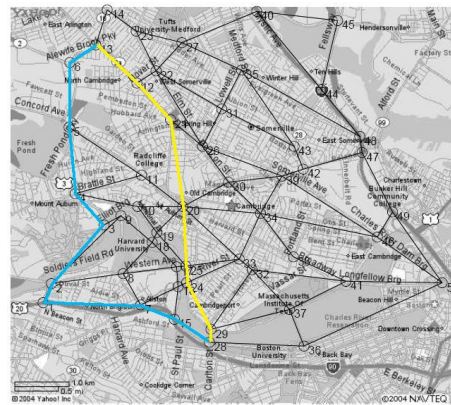

(d)

Figure 4: Increasing α : (a) overview; (b) flow Depot – bank@48; (c) flow bank@48 – bank@28; (d) flow bank@28 – bank@13.

Ordering	Probability
D-48-13-28	0.1182
D-28-48-13	0.3216
D-28-13-48	0.3541
D-13-48-28	0.2061

Table 5: Orderings with relative probability

	mixed	best	%		mixed	best	%
B3_I_1	0.1093	0.2667	59.00	B4_R_1	0.1834	0.3862	52.51
B3_I_2	0.1049	0.2435	56.91	B4_R_2	0.1844	0.4200	56.09
B3_I_3	0.1950	0.2400	18.74	B4_R_3	0.2004	0.3862	48.11
B3_I_4	0.1214	0.2471	50.85	B4_R_4	0.1887	0.3373	44.05
B3_R_1	0.2082	0.3887	46.44	B5_I_1	0.1303	0.3429	61.98
B3_R_2	0.1510	0.2739	44.86	B5_I_2	0.0692	0.2182	68.30
B3_R_3	0.1443	0.2754	47.60	B5_I_3	0.1160	0.3000	61.32
B3_R_4	0.1527	0.3111	50.91	B5_I_4	0.1640	0.3429	52.15
B4_I_1	0.1470	0.3111	52.74	B5_R_1	0.1789	0.3887	53.99
B4_I_2	0.1564	0.3500	55.31	B5_R_2	0.1296	0.2958	56.17
B4_I_3	0.0839	0.2291	63.37	B5_R_3	0.2141	0.4444	51.83
B4_I_4	0.1065	0.2754	61.33	B5_R_4	0.1977	0.4200	52.93

Table 6: Mixed-ordering payoff vs. unmixed best-ordering payoff with percentage decrease

Table 6 reports, for the 24 test scenarios, the payoff of the mixed security-strategy ordering for the vehicle’s route compared with the payoff of the pure strategy where the vehicle always plays the routing with the lowest Z . The mixed strategy, as expected, provides a better overall payoff with up to 68% reduction compared to the corresponding best ordering.

4 Second level optimization

We can further reduce the potential payoff for the robber by limiting the size of the set of nodes with maximum payoff. The method proposed in section 2.1 ensures the minimization of the maximum payoff but does not prevent this payoff from being spread over multiple nodes. By reducing the size of the set V_B defined above, we reduce the likelihood of intersections between nodes the vehicle traverses and the set of V_B . We thus propose a second-level optimization, in which the sum of r_j for all nodes is minimized subject to a guarantee on the maximal payoff computed in the first level optimization. Let Z_p^* be the optimal payoff computed with the first

level optimization of section 2.1. The second level optimization can be formulated as follows:

$$\begin{aligned}
Z_p &= \operatorname{argmin}_p \left\{ \sum_{j \in V} \sum_{(i,j) \in E} (p_{ij}) \alpha_j \right\} \\
\text{s.t. } & \frac{1}{|B|} \sum_B \sum_{(i,k) \in E' | k=j \in V} (p_{ik}) \alpha_j \leq Z_p^* && \forall j \in V \\
& \sum_{i \in V'} (p_{ij}) = \sum_{k \in V'} (p_{jk}) && \forall j \in V' \\
& \sum_{i \in V'} (p_{ij}) = 1 && \forall j \in B' \cup \{d'\} \\
& p_{ij} \geq 0 && \forall (i,j) \in E'
\end{aligned}$$

Table 7 reports, for each instance, the average number, over all possible bank orderings, of nodes with maximal payoff obtained before and after the second-level optimization, and the percentage reduction. Remarkably, the size of the set is reduced between 61.90% and 83.66%.

Once we reduce the size of the maximal-payoff-nodes set, we can recompute the ordering-game matrix and estimate the new order-mixing payoff of our routing strategy. The robber now has a smaller set of ambush sites overlapping between different orderings, and consequently the payoff is substantially reduced.

Table 8 shows the expected payoff for the second-level-optimization routing (*second* in the table) and the percentage decrease in expected payoff (*gap1* in the table) compared with single-level-optimization ordering (labeled with *mixed* in Table 6) and the percentage decrease (*gap2* in the table) with respect to the best bank ordering (labeled with *best* in Table 6). The multi-level routing strategy allows to reduce further the expected payoff by up to 19.83% by better reorganizing the overall network flow.

	M_A^1	M_A^2	(%)		M_A^1	M_A^2	(%)
B3_I_1	39.00	13.17	66.24	B4_R_1	35.46	9.71	72.62
B3_I_2	42.00	16.00	61.90	B4_R_2	31.63	9.50	69.96
B3_I_3	37.17	8.00	78.48	B4_R_3	32.67	10.00	69.39
B3_I_4	36.00	8.50	76.39	B4_R_4	34.33	9.13	73.42
B3_R_1	30.83	7.33	76.22	B5_I_1	36.62	9.82	73.19
B3_R_2	32.17	11.67	63.73	B5_I_2	40.97	15.67	61.76
B3_R_3	32.83	10.67	67.51	B5_I_3	39.88	11.10	72.17
B3_R_4	33.67	9.50	71.78	B5_I_4	34.25	7.92	76.89
B4_I_1	37.04	9.17	75.25	B5_R_1	35.00	9.96	71.55
B4_I_2	35.96	5.88	83.66	B5_R_2	35.70	13.83	61.27
B4_I_3	38.58	15.88	58.86	B5_R_3	34.19	5.98	82.50
B4_I_4	38.83	11.67	69.96	B5_R_4	34.33	11.46	66.63

Table 7: Average size of the set of nodes with maximum payoff for before and after second-level optimization and relative gap

	second	gap1	gap2		second	gap1	gap2
B3_I_1	0.1006	7.95	62.26	B4_R_1	0.1597	12.96	58.66
B3_I_2	0.0908	13.45	62.71	B4_R_2	0.1620	12.15	61.43
B3_I_3	0.1638	16.02	31.76	B4_R_3	0.1703	15.02	55.90
B3_I_4	0.1058	12.91	57.20	B4_R_4	0.1593	15.61	52.79
B3_R_1	0.1865	10.42	52.02	B5_I_1	0.1095	15.99	68.06
B3_R_2	0.1310	13.29	52.19	B5_I_2	0.0555	19.83	74.58
B3_R_3	0.1214	15.87	55.92	B5_I_3	0.0956	17.65	68.15
B3_R_4	0.1416	7.25	54.47	B5_I_4	0.1365	16.79	60.19
B4_I_1	0.1286	12.50	58.65	B5_R_1	0.1571	12.14	59.57
B4_I_2	0.1473	5.83	57.92	B5_R_2	0.1151	11.19	61.07
B4_I_3	0.0739	11.94	67.74	B5_R_3	0.1969	8.02	55.70
B4_I_4	0.0879	17.43	68.07	B5_R_4	0.1692	14.38	59.70

Table 8: Second-level mixed strategy and relative gap w.r.t. single-level mixed strategy and single-level best ordering

5 Conclusions and outlook

Our paper has suggested a multi-destination routing method for fund transfers under conditions of risk. Based on the assumptions above, our method allows substantial reduction in robber payoffs by a two-level game and a primary and secondary optimization. This method is very much applicable to urban-ambush problems, and exploits more of such urban network than common path-based routing methods.

The second-level optimization proposed above may be applicable in more contexts, as it permits to identify the truly critical nodes that limit further improvement. Further use could also be made of our multiple-layer network. By introducing the multiple layers, our model allows the imposition of an approximate temporal framework onto a problem with flow-based solution. Thus, some of the benefits of path-based solutions are joined with the ease of the flow-based solution. Our multi-layer network could thus be used to approximate ambush success rates that vary in function of the time of day. If we assume that layers correspond approximately to a given period in the day, i.e. the link between the depot and bank 13 is transited between 07h00 and 08h00, then we can adjust the α 's to be commensurate with the traffic and danger conditions at this hour. And so on for each layer. Furthermore, to approximate varying sums in the bank car over the course of the day, we could add a money constant $\$b$ to our optimization that varies in function of the layer b in the set B . A risk equation incorporating a varying α and a varying $\$$ would appear as:

$$r_j = \frac{1}{|B|} \sum_{b \in B} \$b \sum_{(i,k) \in E' | k=j \in V} (p_{ik}) \alpha_j^b$$

However, extension of this flow-based method to multiple vehicles should be undertaken with care. The assumption that vehicles will not react dynamically to ambushes becomes increasingly false with increased number of vehicles. It is very unlikely that a number of bank cars will continue on their assigned routes after one has set off the klaxon.

References

- Basar, T. and Olsder, G. (1999). *Dynamic Noncooperative Game Theory*, SIAM, Philadelphia, PA.
- Bell, M. G. H. (2004). Games, heuristics, and risk averseness in vehicle routing problems, *Journal of Urban Planning and Development* **130**(1): 37–41.
- Carotenuto, P., Giordani, S. and Ricciardelli, S. (2007). Finding minimum and equitable risk routes for hazmat shipments, *Computers & OR* **34**(5): 1304–1327.
- Erkut, E. and Verter, V. (1998). Modeling of transport risk for hazardous materials, *Operations Research* **46**(5): 625–642.
- Gentry, S. E. and Feron, E. (2004). Modeling musically meaningful choreography, *Systems, Man and Cybernetics, 2004 IEEE International Conference on*, pp. 3880–3885.
- Joseph, F. A. (2005). *Path-planning strategies for ambush avoidance*, Master's thesis, Massachusetts Institute of Technology.
- Likhachev, M. and Stentz, A. (2007). Goal directed navigation with uncertainty in adversary locations, *IROS*, pp. 4127–4134.
- List, G. F., Mirchandani, P. B., Turnquist, M. A. and Zografos, K. G. (1991). Modeling and analysis for hazardous materials transportation: Risk analysis, routing/scheduling and facility location, *Transportation Science* **25**(2): 100–114.
- Root, P., De Mot, J. and Feron, E. (2005). Randomized path planning with deceptive strategies, *American Control Conference, 2005*, Vol. 3, pp. 1551–1556.
- Ruckle, W. H. (1983). *Geometric Games and Their Applications*, Pitman Advanced Publishing Program, Boston, MA.

- Toth, P. and Vigo, D. (eds) (2001). *The vehicle routing problem*, SIAM, Philadelphia, PA, USA.
- Zoroa, N., Zoroa, P. and Fernández-Sáez, M. J. (1999). A generalization of ruckle's results for an ambush game, *European Journal of Operational Research* 119(2): 353–364.