

A STATOR FLUX ORIENTED VECTOR CONTROL FOR INDUCTION MOTOR DRIVES

A. Schwery*, B. Kawkabani*, J.J. Simond*, A. Elmaleh**

*Swiss Federal Institute of Technology, **Warner Electric S.A, SWITZERLAND

Abstract - The present paper describes a stator flux oriented control strategy using state space controllers. The optimal determination of different controllers' parameters (suitable placement of poles, continuous adaptation of coefficients to the operating point of the drive) leads to an independent control of the stator flux and the torque in different operating conditions, and consequently to good dynamic performances of the drive. The effectiveness of the proposed system is verified by computer simulation. The control implementation on a Motorola DSP 56002 is in progress.

Keywords: Induction machine, stator flux oriented control, adaptation of controllers' parameters, PWM voltage source inverter.

INTRODUCTION

During the last few years, the control of induction machines by the field oriented method has become the subject of several publications [1,2]. Many papers describe controllers of induction motor drives based on the **rotor** flux orientation [3]. The main advantage of this method is that decoupling between torque and flux can easily be achieved. Nevertheless, exact knowledge of the machine parameters (especially the rotor time constant or the rotor resistance) is necessary to guarantee the orientation of the rotor flux vector along the direct axis, and methods to balance the variation of these parameters have to be provided.

In this paper, a new control scheme based on the **stator** flux oriented method, less sensitive to the variation of the machine parameters, is presented. Contrary to the rotor flux strategy, a decoupling between currents in the two axes does not imply a decoupling between torque and flux in the stator flux strategy. Therefore it is necessary to add a flux controller to the control scheme.

Knowing the stator resistance, flux are deduced from the acquisition of the stator currents and voltages [4]. The control system uses these flux and measurements of currents and speed to regulate the speed and flux to the desired levels. Speed and flux can be regulated independently.

Simulation results using a close-to-reality model of the frequency converter show a good dynamic behaviour of the studied system drive in different operating conditions.

SYSTEM

Figure 1 represents the studied system and can be divided into three parts: The **induction machine**, the **frequency converter** which ensures the amplification of the signals calculated by the **controller part**.

All parameters and variables in this paper are expressed in per unit (p.u.) except the time which is expressed in seconds (s).

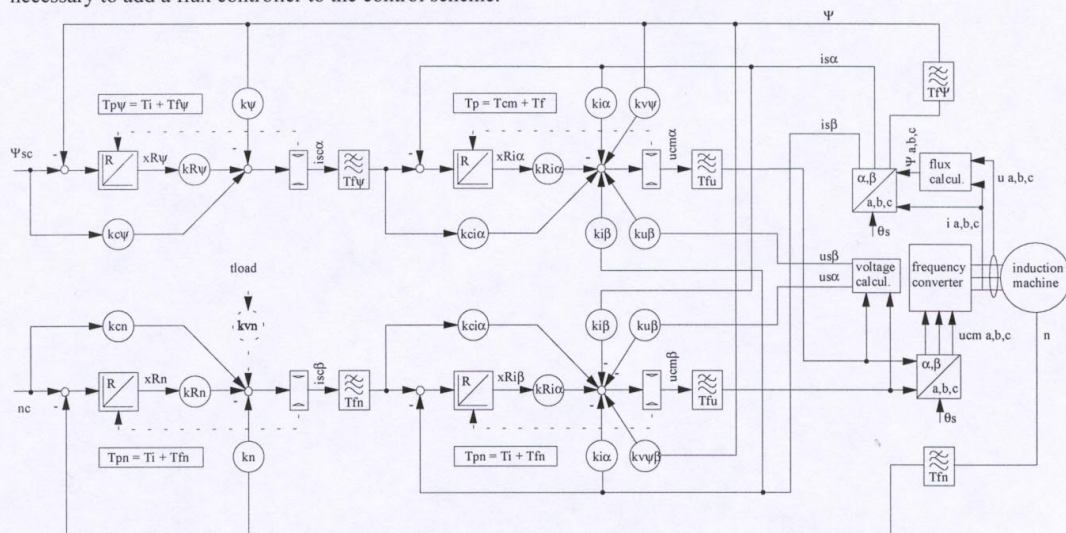

figure 1: Induction machine control with stator flux orientation

INDUCTION MACHINE EQUATIONS

For the control strategy presented in this paper a flux oriented reference frame with an angular speed of ω_s is used (axes α, β). The considered machine is a squirrel cage induction machine modelled in the same reference frame therefore one has:

$$\frac{d}{dt}i_{s\alpha} = -\frac{1}{T_s}i_{s\alpha} + f_r\omega_n i_{s\beta} + \frac{\omega_n}{l_\sigma}u_{s\alpha} + \frac{1}{l_\sigma T_r}\Psi_s \quad (1)$$

$$\frac{d}{dt}i_{s\beta} = -f_r\omega_n i_{s\alpha} - \frac{1}{T_s}i_{s\beta} + \frac{\omega_n}{l_\sigma}u_{s\beta} - \frac{\omega_n\omega_m}{l_\sigma}\Psi_s \quad (2)$$

$$\frac{d}{dt}\Psi_s = \omega_n(u_s - r_s i_s - j f_s \Psi_s) \quad (3)$$

$$T_m \frac{d}{dt}\omega_m = t_{em} + t_{ext} \quad (4)$$

The system is expressed in a **stator** flux oriented reference frame and the real axis of this frame (α) is aligned with the stator flux, at any moment the flux becomes:

$$\underline{\Psi}_s = \Psi_{s\alpha} = \Psi_s \quad (5)$$

The electromagnetic torque is given by:

$$t_{em} = \Psi_{s\alpha} i_{s\beta} \quad (6)$$

Considering the imaginary part of equation (3) the stator frequency, used for Park's transformation, can be determined.

$$f_s = \frac{u_{s\beta} - r_s i_{s\beta}}{\Psi_s} \quad (7)$$

FREQUENCY CONVERTER

To take into consideration the time delay caused by the voltage source inverter a first order differential equation is used.

$$\frac{d}{dt}u_s = -\frac{1}{T_{cm}}u_s + \frac{u_z}{T_{cm}}u_{cm} \quad (8)$$

T_{cm} : time constant of the inverter

u_z : dc voltage link

For a close-to-reality simulation this way of modelling the inverter would be too optimistic. The real voltages applied to the machine are not sinusoidal. Therefore a more realistic model of the inverter is used [5]. Considering the voltage set values the switching instants of the six IGBT's in the converter branches are calculated using the vector modulation method. The stator voltages are then calculated considering the IGBT's to be ideal switches.

It is important to point out that for the calculation of the controllers' parameters equation (8) is taken into consideration whereas the strategy described above is used to model the converter. Figure 1 shows that stator voltages are used in the current control loop. Instead of measuring the real voltages on the machine they can be estimated using the set point values $u_{cm\alpha}, u_{cm\beta}$ and equation (8).

CONTROL SYSTEM

Flux linkage in the stator of the machine are determined using stator resistance value and measurements of stator currents and voltages. Then currents and flux are transformed using Park's transformation at the entrance of the control system. Four state controllers are used to control torque and flux of the machine. Speed, flux and current controllers are mounted in cascade. Thus inner quantities may easily be limited. All controllers are equipped with limiters protecting the controlled system from overload. During limitation, the integral components are corrected (anti-reset-windup). Finally at the exit of the control system the two set point values of the stator voltages are retransformed using the inverse Park transformation. All controllers are designed as being continuous and then transformed into digital by Padé approximation [6].

A detailed description of the determination of the controllers' parameters for a rotor flux oriented reference frame strategy was presented in [3]. In this study the same method adapted to a stator flux oriented reference frame strategy is presented [7] pointing out the differences between the two strategies and presenting the controllers' parameters for the stator flux oriented reference frame strategy.

Current controllers

As shown in figure 1 state space controllers are used to control the currents in both axes. The parameters of these two regulators are determined in order to ensure good dynamic response and decoupling between the two components of the stator current. Considering equations (1 to 3) and the controllers' equations an equation relying the currents in the two axes can be established. This one can be simplified considering the assumption that the flux variation can be neglected. This yields:

$$\frac{d^2}{dt^2}i_s = \epsilon_1 \frac{d}{dt}i_s + \epsilon_2 i_s + \epsilon_3 i_{sc} + \epsilon_4 x_{Ri} + \epsilon_5 \Psi_s \quad (9)$$

Decoupling can be achieved by imposing the imaginary parts of the coefficients $\epsilon_1 \dots \epsilon_5$ to be equal to zero. Condition which defines the following parameters of the current controllers:

$$k_{u\beta} = -\frac{f_r \omega_n T_p}{u_z} \quad (10)$$

$$k_{i\beta} = \frac{l_\sigma f_r}{u_z} \left(\frac{T_p}{T_s} - 1 \right) \quad (11)$$

$$k_{c i \beta} = 0 \quad (12)$$

$$k_{R i \beta} = 0 \quad (13)$$

$$k_{v \psi \beta} = \frac{1}{u_z} \left[n + f_r \frac{T_p}{T_r} \right] \quad (14)$$

The continuous adaptation of these parameters to the operating point of the drive ensures a decoupling between the two components of the stator current (a variation of $i_{s\alpha}$ has no influence on $i_{s\beta}$ respectively $i_{s\beta}$ on $i_{s\alpha}$). Because in the realization of the control the stator voltages are estimated rather than measured a feedback loop of this variable is omitted. This yields:

$$k_{u\alpha} = 0 \quad (15)$$

By imposing not only the imaginary part but also the real part of ε_s to be equal to zero the following expression can be determined.

$$k_{v \psi \alpha} = -\frac{T_p}{\omega_n u_z} \left[\frac{1}{T_p T_r} - n f_r \omega_n^2 \right] \quad (16)$$

This corresponds to the elimination of the influence of the flux on the current regulation in steady-state conditions.

The characteristic equation of the system expresses a relation between the parameters of the feedback loop and the poles of the system. Therefore these parameters can be defined by pole placement. The poles are placed as shown in figure 2 to achieve an optimal relative damping [6].

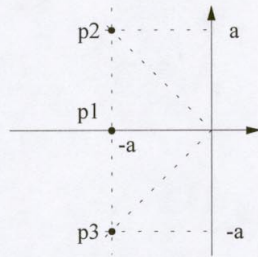

figure 2: pole placement

One obtains:

$$k_{i\alpha} = \frac{l_\sigma T_p}{\omega_n u_z} \left(4a^2 - \frac{1}{T_p T_s} - f_r^2 \omega_n^2 \right) \quad (17)$$

$$k_{R i \alpha} = 2a^3 \frac{l_\sigma T_p}{\omega_n u_z} \quad (18)$$

$$k_{c i} = \frac{k_{R i}}{a} \quad (19)$$

where

$$a = \frac{1}{3} \left(\frac{1}{T_p} + \frac{1}{T_s} \right) \quad (20)$$

Flux controller

The need of a flux controller will be discussed later on. For the determination of the flux controller parameters the current control loop can be replaced by a first order differential equation.

$$i_{s\alpha} = \frac{1}{1 + s T_{p\psi}} i_{sc\alpha} \quad (21)$$

where

$$T_{p\psi} = T_i + T_{f\psi} \quad (22)$$

with T_i : equivalent time constant of the current control loop
and $T_{f\psi}$: time constant to take into account the delay due to filtering.

Using equations (1 to 3) a transfer function relying stator flux and the real part of the stator current can be determined [5]. By neglecting a term containing the square of the slip the equation is given by:

$$\Psi_{s\alpha} = \frac{l_s (\sigma T_r s + 1)}{(T_r s + 1)} i_{s\alpha} \quad (23)$$

Considering figure 1 the set point value of $i_{s\alpha}$ can be expressed as follows :

$$i_{sc\alpha} = k_{c\psi} \Psi_{sc} - k_{\psi} \Psi_s + k_{R\psi} x_{R\psi} \quad (24)$$

Pole placement yields:

$$k_{R\psi} = \frac{2a^3 \Psi T_p \Psi T_r}{l_\sigma} \quad (25)$$

$$k_{\psi} = \frac{3a \Psi T_r T_p \Psi - T_r - T_p \Psi}{l_\sigma \sigma T_r} \quad (26)$$

$$k_{c\psi} = \frac{k_{R\psi}}{a\psi} \quad (28)$$

where $a\psi$ is the real solution of:

$$a^3 \Psi - a^2 \frac{2}{T_r \sigma} + a \Psi \frac{3}{2T_r^2 \sigma^2} - \frac{T_r + T_p \Psi - T_r \sigma}{2\sigma^2 T_r^3 T_p \Psi} = 0 \quad (27)$$

Speed controller

The same type of controller as for the flux control loop is used to control the speed of the machine. The same methods used to calculate the coefficients of the flux controller have been applied.

COMPARISON BETWEEN ROTOR AND STATOR FLUX STRATEGIES

The equation set describing the machine in a rotor flux oriented reference frame would almost be the same as (1 to 3) except equation (3) which becomes:

$$\frac{d}{dt} \Psi_r = -\frac{1}{T_r} (\Psi_r - x_h i_{s\alpha}) \quad (29)$$

and instead of (7) one has

$$f_r = \frac{x_h}{\omega_n T_r} \Psi_r i_{s\beta} \quad (30)$$

which is used to calculate the synchronous speed of the reference frame. Furthermore the expression of the torque in the rotor reference frame becomes:

$$t_{emr} = \frac{x_h}{x_r} \Psi_r i_{s\beta} \quad (31)$$

Equation (29) shows that the rotor flux depends only on the real part of stator current whereas the stator flux (3) depends not only on that latest but also on the real part of the stator voltage $u_{s\alpha}$. In the rotor flux strategy a decoupling between $i_{s\alpha}$ and $i_{s\beta}$ ($i_{sc\beta}$ and $i_{s\alpha}$) implies a decoupling between flux and torque (equations (29), (31)).

In the stator flux strategy this is not true. Any variation of $i_{s\beta}$, which is necessary to change the torque (6) will change $u_{s\alpha}$ and therefore the stator flux. Thus the need of a flux controller to maintain the flux level constant. This flux controller can be used to change the flux level, for example, for a fast starting-up or while operating in field weakening range.

Equation (29) depends on inner quantities of the machine especially on the rotor time constant T_r whereas equation (3) depends only on the stator resistance. Because flux estimation (3) and reference speed estimation (7) are less dependent on temperature variation (they do not depend on the rotor resistance), the stator flux reference frame strategy can be expected to be less sensitive to machine parameter variations than the rotor flux strategy.

SIMULATION RESULTS

The system described above is programmed on a 486 PC. Any change of the set values can be simulated.

Figures 3 to 5 show a **starting-up** of a machine with a change of the load torque (t_{ext}) after the desired speed has been reached. Figure 3 shows a little speed overshoot due to the sudden change of the load torque (which can be seen on figure 4) without any effect on the flux level (figure 5).

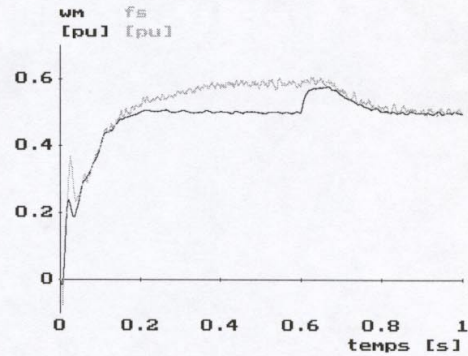

figure 3: speed and stator frequency

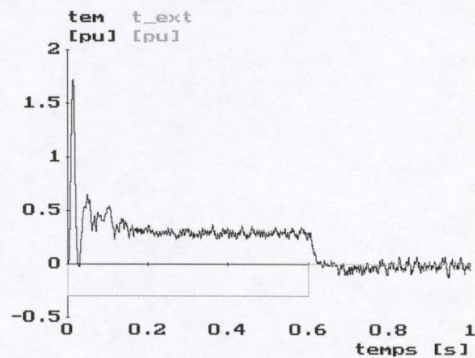

figure 4: torque and load torque

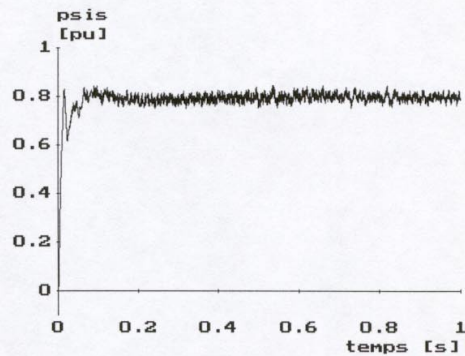

figure 5: stator flux

A **change of speed** set point value is represented in figures 6 to 8. Figure 6 shows the speed and its set point value. In order to reach a speed of 0.7 p.u. the flux level has to be decreased (figure 7, field weakening). Finally figure 8 shows the evolution of the torque, needed to change the speed of the machine.

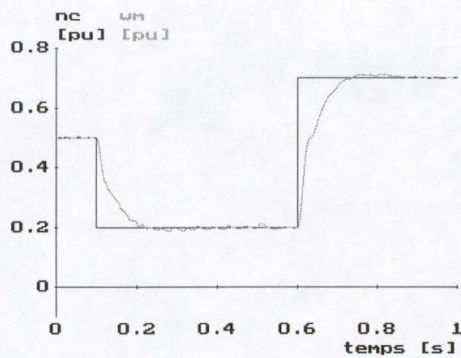

figure 6: speed set point value and speed

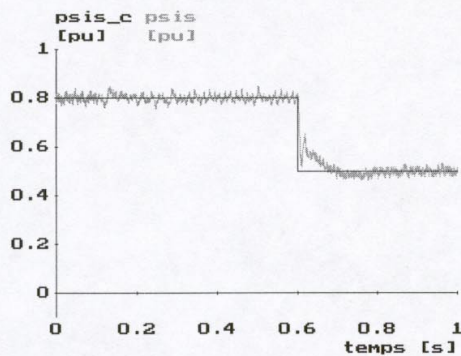

figure 7: flux set point value and corresponding flux

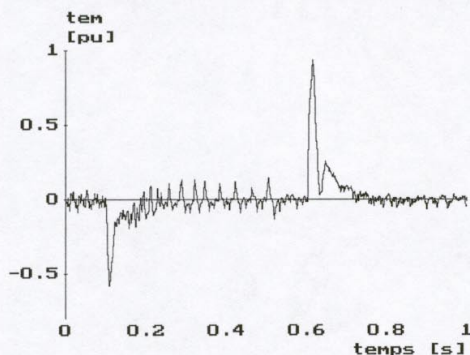

figure 8: torque

HARDWARE REALIZATION

An implementation of the control algorithm on a Motorola DSP 56002 is in progress. Data acquisition cards provide the measured quantities like flux, currents and voltages. These cards have been tested on other applications [4]. Speed information is obtained from an incremental shaft encoder which signal is transformed in rpm on a separate card. Finally the vector modulation method is realized in hardware in order to save processing time on the DSP.

CONCLUSION

The control of an induction machine using a stator flux strategy has been presented. The major differences in comparison to a rotor flux strategy have been listed and commented. Namely it has been shown that the stator flux strategy depends less on the rotor resistance. The need of a flux controller has been explained. Simulation results show that good dynamic performances of the drive as well as an independent control of torque and flux can be obtained by using the proposed strategy.

The implementation of the control system on a DSP 56002 is in progress. First results in open loop have been obtained. The feasibility of the proposed control system has to be confirmed by a complete realization.

REFERENCES

- [1]Lajoie-Mazenc E., *Vector control technics of induction machines for high performances adjustable speed drives*, Edition EDF, January 1992
- [2]Profumo F., Pastorelli M., Ferraris P., De Doncker R.W., *Comparison of universal field oriented (UFO) controllers in different reference frames*, EPE 1991, Firenze
- [3]Feller Pierre: *Réglages analogiques modernes appliqués à la machine à courant continu et à la machine asynchrone*, Thesis EPFL No. 548, 1984, Lausanne
- [4]M.T. Nguyen, M. Tu Xuan, J.J. Simond, *Digital transient torque measurements for rotating or linear AC machines (real time measurement)*, EPE 1995, Sevilla (Spain), pp. 1.319 - 1.321
- [5]Schwery Alexander, *Modèle d'un convertisseur PWM, Régulateur de flux*, internal report, LEME EPFL, No. 94/110, 1994, Lausanne
- [6]Bühler Hansruedi, *Conception de systèmes automatiques*, Presses polytechniques Romandes, 1988, Lausanne, p. 363-376
- [7]Jeitziner Fabian, Schwery Alexander, *Contrôle vectoriel d'une machine asynchrone*, Diploma project, LEME EPFL, 1994, Lausanne

A. Schwery*, B. Kawkabani*, J.J. Simond*, A. Elmaleh**

*Swiss Federal Institute of Technology, Electrical Engineering Dept., CH-1015 Lausanne
tel: 4121/6934690, fax: 4121/6932687

**Warner Electric S.A., La Pierreire, CH-1029 Villars-Ste-Croix, SWITZERLAND
tel: 4121/6313333, fax: 4121/6360509