

**A new fast ion source and detector for investigating the interaction of turbulence
with supra-thermal ions in a simple magnetized toroidal plasma.**

G. Plyushchev, H. Boehmer*, A. Diallo, A. Fasoli, I. Furno, W. W. Heidbrink*, B. Labit,
S. H. Müller, M. Podestà, F. M. Poli, Y. Zhang*

Centre de Recherches en Physique des Plasmas, CRPP-EPFL, CH- 1015, Lausanne,
Switzerland

* Department of Physics and Astronomy, University of California, Irvine, California
92697, USA

Abstract

A specific experimental apparatus consisting of an ion source and a detector for the investigation of the interaction between supra-thermal ions and drift-wave turbulence is developed on the TORoidal Plasma Experiment (TORPEX). Due to the small plasma temperature ($\sim 5\text{eV}$), a spatially localized, small-size ion source ($\sim 4\text{cm}$) mounted inside the vacuum vessel, with relatively low ion energy ($\sim 100\text{eV}-1\text{keV}$) can be used. The source consists of an aluminosilicate Li-6 ion emitter (6 mm diameter, 10-30 μA current) installed on a 2D poloidally moving system. The location, energy and current density profile of the ion beam will be measured using a 2D movable gridded energy analyzer.

Introduction

The plasma of ITER and future thermonuclear reactors will be heated by the products of thermonuclear reactions (He-4) with very high energy ($\sim 3.5\text{MeV}$), in other words by fast non-thermal ions. These non-thermal ions will carry large amount of power ($\sim 200\text{MW}$ for a fusion power of 1GW). In existing tokamaks, fast ions can be generated by additional ion heating (neutral beam injection or ion cyclotron heating)¹ or even electron heating². Highly energetic ions can exert a strong influence on plasma properties, such as temperature and density profiles, turbulence, equilibrium etc.¹, via direct heating, by exciting instabilities (Alfvén frequency modes) or by interacting with existing instabilities (e.g. sawteeth). Another very important question, related both to the basics physics of turbulence and to the anomalous transport, is how low frequency plasma turbulence influences fast ions, and, in turn, how fast ions can influence turbulence.

This problem can be addressed in the TORoidal Plasma Experiment (TORPEX)³ in a relatively simple experimental environment. Its plasma provides an easy access for diagnostics, and is subject to drift-wave instabilities and turbulence³. In this article we describe the main elements of the design of a fast ion source ($100\text{eV}-1\text{keV}$), a gridded energy analyser and a 2D poloidally moving system for the source and gridded energy analyser to investigate the fast ion-turbulence interaction over almost the entire poloidal cross-section.

Experimental setup

The TORPEX device has a major radius $R=1\text{m}$, a minor radius $a=0.2\text{m}$, a mainly toroidal magnetic field $B_T < 0.1\text{T}$ and a small vertical component $B_z < 4\text{mT}$. The plasma is produced

by microwaves launched from the low field side in the Ordinary mode, with a frequency of 2.45GHz and a power $P_{RF} < 10\text{kW}$. A toroidal electrical field ($V_{loop} < 10\text{V}$) can also be induced to produce a plasma current ($I_p < 1\text{kA}$ for $\sim 3\text{ms}$) and to close magnetic flux surfaces in the plasma. The plasma discharge lasts up to 1.8s. The typical electron temperature is $T_e \sim 5\text{eV}$ for both hydrogen and argon plasmas, with an electron density $n_e \sim 3 \times 10^{16}\text{m}^{-3}$ for hydrogen and $\sim 2 \times 10^{17}\text{m}^{-3}$ for argon (with addition of ohmic power the density can rise up to $\sim 2 \times 10^{18}\text{m}^{-3}$). These low temperatures and densities allow highly localized measurements of plasma parameters with sets of different probes inserted directly in the plasma core. More than 200 channels are acquired simultaneously during the whole discharge, with a sampling rate of 250kHz.

To investigate fast ion – turbulence interactions on TORPEX we should have a controllable fast ion source and diagnostics appropriate to measure the fast ions beam parameters, the background plasma profiles and the turbulence properties. TORPEX plasmas are characterized by electrostatic fluctuations and turbulence originating from drift-interchange instabilities, driven by pressure gradient and magnetic curvature, i.e. mechanism relevant to magnetic fusion³. The fast ion energy should be significantly higher than the plasma temperature, but low enough that fast ions are confined by the toroidal magnetic field. For TORPEX these conditions are satisfied for fast ion energies from $\sim 100\text{eV}$ to $\sim 1\text{keV}$ for Li-6 ions. The Li-6 particle with 100eV energy has a Larmor radius of about 3.5cm (for $B_T = 0.1\text{T}$). This particle makes one toroidal turn in 0.11ms. The slowing down time for typical TORPEX plasma parameters is $\sim 30\text{ms}$. Taking into account its smallness relative to the energy diffusion time ($\sim 7\text{s}$) the ion beam is expected

to remain mono-energetic. The critical energies for typical hydrogen and argon plasma are equal to 440eV and 180eV respectively; below these energies the collisions of the fast ions with thermal ions dominate over fast ion – electron collisions.

After injection, the beam tends to diverge due to at least five mechanisms: particle drifts, space charge, classical transport, poloidal electric field and turbulent transport. Experiments with and without plasma but with magnetic field will help us to separate the two first and three last mechanisms. Calculations based on the single particle approximation show the possibility to control the beam trajectory and the particle drift divergence with the vertical magnetic field. The space charge divergence is negligible because of the small beam current. The divergence due to poloidal electric field and turbulent transport will be investigated using a gridded energy analyser. Both the source and the analyser will be installed on 2D poloidally moving systems in two different cross-sections (Fig.1), to be able to change the fast ion current deposition and to measure the fast ion current profile.

The investigations of plasma turbulence and background profiles will be carried out with the help of Langmuir probes that already exist on TORPEX and some new diagnostics which will be developed soon. These include a laser induced fluorescence (LIF) system for the ion velocity distribution function measurements, a fast camera in the visible range of light for direct fluctuation measurements, a set of edge Langmuir probes which will expand the coverage area of the existing probes and a 2D poloidally movable flux probe.

I. Fast ion source

Due to the relatively low energy required, a small cylindrical ion source (~4cm length, 2cm diameter) can be used. Such ion source can be installed directly inside the vacuum vessel. The ion source consists of two aligned grids (screen grid and accelerating grid) and of an ion emitter (Fig.2). The screen grid will have the same potential as the plasma to minimize perturbations. The accelerating grid will be powered by a high voltage modulated power supply. The beam can be focused by varying the voltage between the accelerating and the screen grids. The wide energy range of fast ions (100eV-1keV, the upper limit being determined by dielectric breakdown voltage of the insulators) will allow us to investigate the energy dependencies. Using light ions is preferable because such ions will have relatively high speed, which facilitate the fast ion-electron interactions. The current density of these ions should be small enough to prevent collective wave excitation and to avoid two stream instabilities. The emitter should cause low gas load to minimise the perturbation to the background plasma. To satisfy these requirements, an aluminosilicate Li-6 ion emitter has been chosen⁴. The emitter has 6mm beam diameter, 10-30 μ A beam current, which depends on the extracting voltage according to the Schottky effect, and operates at a cathode temperature of about 1000°C. The life time of the emitter is expected to exceed 300 hours. Such ion source is not sensitive to magnetic fields up to 0.1T, which is appropriate for TORPEX.

II. Gridded energy analyser

A gridded energy analyser consisting of two grids and an anode will give information about the location, energy and current density profile of the ion beam. The decelerating

grid will be biased with a sweeping voltage (frequency $f \sim 1\text{kHz}$) that will determine a temporal resolution of at least 1ms. The spatial resolution is determined by the inlet diameter of the analyser (6mm) and by the accuracy of the 2D system positioning ($< 5\text{mm}$). A reasonable energy resolution (about 0.1eV) to observe space transport is aimed.

III. 2D poloidally moving system

The fluctuation and turbulence level strongly depend on background plasma profiles (e.g. on the position on the pressure gradient) and for different regimes the region of interest may vary in the poloidal cross-section. Thus, it is necessary to install both the fast ion source and the gridded energy analyser on a 2D poloidally moving system to be able to change the fast ion deposition radially and vertically and to measure the fast ion current profile over the whole plasma cross-section. Considering the high price and the limited lifetime of conventional bellows, for both motions we have chosen to use sliding seal feedthroughs with differential pumping (Fig.3), a solution similar to that adopted on LAPD⁵. The design of the angular feedthrough based on a steel ball allows an angular excursion of up to 70° . Ceramic tubing will support the probe inside the plasma column. As a consequence, the linear feedthrough will be placed approximately 40cm away from the ball (see Fig.3). Such construction gives us the possibility to cover almost the entire poloidal cross-section, except for a small upper-right part, a limitation caused by outside structures of TORPEX. The positioning of the source and the detector will be achieved remotely using stepping motors and controlled through software.

Acknowledgments

The Authors wish to thank J. M. Mayor for a design of the 2D poloidally moving system.

This work is partly funded by the “Fonds National Suisse de la Recherche Scientifique”.

¹ITER Physics Base Editors, Nucl. Fusion **39**, 2137 (1999)

²A. N. Karpushov, S. Coda, B. P. Duval, Proc. 30th EPS Conf., Vol. 27A, Part 3, p123
(2003)

³A. Fasoli, B. Labit, M. McGrath, S. H. Müller, M. Podestà, F. M. Poli, and G.
Plyushchev, Phys. Plasmas, to be published (2006)

⁴<http://www.cathode.com/pdf/tb-118.pdf>

⁵D. Leneman, and W. Gekelman, Rev. Sci. Instrum. **72**, 3473 (2001)

Figure captions

FIG.1. Toroidal cross-section of TORPEX with (1) Fast ions source with support; (2) Gridded energy analyser; (3) Trajectory of fast ions; (4) Vacuum vessel; (5) Ports.

FIG.2. (a) Scheme of the source. Shown are: (1) Screen grid; (2) Accelerating grid; (3) Fast ion source. (b) Example of the Li ion source (characteristic dimension ~10cm) which was developed in University of California, Irvine.

FIG.3. Drawing of 2D poloidally moving system. Main elements of the drawing are: (1) Vacuum vessel; (2) Coverage area; (3) Angular and (4) linear motion feedthrough; (5) Ceramic tube; (6) remote linear motion system; (7) arm for remote angular motion.

Figures

Fig.1.

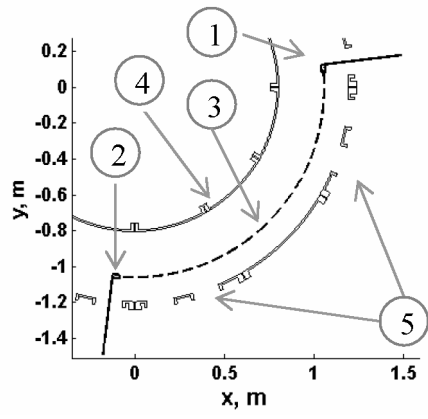

Fig.2.

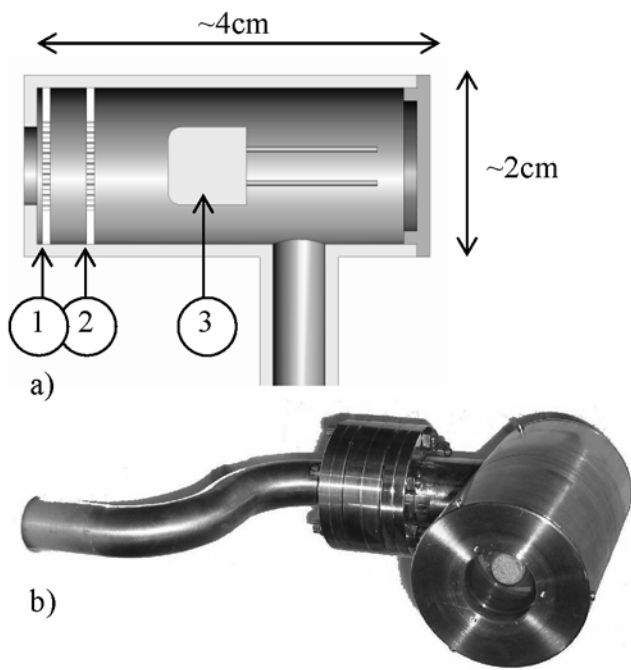

Fig.3.

