

A DOA ESTIMATION METHOD FOR AN ARBITRARY TRIANGULAR MICROPHONE ARRANGEMENT

Amin Karbasi and Akihiko Sugiyama[†]

School of Computer and Communication Sciences, Ecole Polytechnique Fédérale de Lausanne
CH-1015 Lausanne, Switzerland

[†] NEC Media and Information Research Laboratories
1753, Smimonumabe, Nakahara-ku, Kawasaki 211-8666, Japan

ABSTRACT

This paper proposes a new DOA (direction of arrival) estimation method for an arbitrary triangular microphone arrangement. Using the phase rotation factors for the crosscorrelations between the adjacent-microphone signals, a general form of the integrated cross spectrum is derived. DOA estimation is reduced to a non-linear optimization problem of the general integrated cross spectrum. It is shown that a conventional DOA estimation for the equilateral triangular microphone arrangement is a special case of the proposed method. Sensitivity to the relative time-delay is derived in a closed form and demonstrated for different microphone arrangements. Simulation results demonstrate that the deviation of estimation error in the case of 20 dB SNR is less than 1 degree which is comparable to high resolution DOA estimation methods.

1. INTRODUCTION

Direction-of-arrival (DOA) estimation of a sound source by using microphone arrays has been an active research topic since the early 1990's [1]. It has important applications in human computer interfaces such as video conferencing [2]-[3], speech enhancement [4] and speech recognition [5]. The fundamental principle behind DOA estimation is to capture the phase information present in signals picked up by microphones.

There are three main categories in DOA estimation methods. The first group is based on the output power of steered beamformer, such as MVB (maximum variance beamformer) [6] and DSB (delay and sum beamformer) [7]. The second group that resolves the multiple source localization problem is based on high-resolution subspace techniques, such as MUSIC [8] and ESPRIT [9]. The third set of methods is based on the estimation of the time delay of arrival (TDOA) [10] between signals at a pair of microphones. These TDOA methods are used to find the source position based on the information of the microphone arrangement. Due to the simplicity and a small number of computations, TDOA estimation methods are widely used in real time systems.

In order for the above methods to be more effective, a good microphone geometry also needs to be determined. In linear microphone arrays the front-rear discrimination [11] is one of the most serious problems. To avoid this drawback, other types of microphone arrays are desirable, such as equilateral triangular [12] and circular [14] microphone arrays. However, these types of arrangement impose a restriction on the microphones' locations, resulting in limitations on applications.

This paper proposes a new DOA estimation method for an arbitrary triangular microphone arrangement. In the following section, two-microphone DOA estimation and a DOA estimation method based on equilateral triangular microphone array [12] are reviewed. The proposed method is developed in Section 3. Finally, Section 4 demonstrates performance of the proposed method by computer simulations.

2. CONVENTIONAL METHOD

2.1 DOA Estimation With Two Microphones

The fundamental concept for every time-delay-of-arrival method is based on the two-microphone arrangement. Considering two signals, $x_1(n)$ and $x_2(n)$, with a relative time-delay of τ , the following equations are obtained.

$$x_1(n) = s(n) + n_1(n), \quad (1)$$

$$x_2(n) = s(n - \tau) + n_2(n), \quad (2)$$

where $s(t)$ represents the incident signal on one of the microphones. The time delay between the signals at a pair of microphones is equal to

$$\tau = \frac{d \sin \theta}{c}, \quad (3)$$

where c is the sound velocity. It is important to notice that this delay factor is a function of the source DOA θ . In other words, the signal incident on one of the microphones is a time delayed version of the other.

The Fourier transform of $x_1(n)$ and $x_2(n)$ are given by

$$X_1(\omega) = S(\omega) + N_1(\omega), \quad (4)$$

$$X_2(\omega) = S(\omega)e^{-j\omega\tau(\theta)} + N_2(\omega), \quad (5)$$

where ω is the radian frequency. Under a condition that noises at two microphones are uncorrelated, the cross correlation of $x_1(n)$ and $x_2(n)$ is represented in the frequency domain by

$$\Phi_{12}^{(\omega)}(\theta) = E[X_1^*(\omega)X_2(\omega)] = \Phi_{ss}(\omega)e^{-j\omega\tau(\theta)}, \quad (6)$$

where $E[\cdot]$ denotes the mathematical expectation and $\Phi_{ss}(\omega)$ is the power spectral density of $s(n)$. Hence, based on $\tau(\theta)$ that gives the maximum cross correlation, the DOA θ can be obtained. However, the value of $\tau(\theta)$ is a function of $\sin \theta$ and for this reason, this method can not discriminate whether the speaker is in front of or behind the microphone array (the front-rear problem). This drawback is inherent in all linear arrays because the directivity is symmetrical about the array surface. In order to solve this problem, other types of microphone arrays are useful. One of the simplest arrangements that is not linear is a triangular microphone array.

2.2 Equilateral Triangular Microphone Array

Hioka and Hamada proposed a tracking algorithm for a speaker direction using microphones located at the vertices of an equilateral triangle [12]. It consists of three main functions, *i.e.* calculation of cross spectrum, harmonic selection, and minimization of a cost function. They have shown that, in the case of equilateral microphone arrangement, DOA estimation is reduced to a non-linear minimization problem. Furthermore, the front-rear discrimination is no longer necessary. However, the equilateral condition causes a large constraint on the microphone arrangement from a practical point of view. It is desirable to remove such a restriction on the microphone arrangement and allow an arbitrary triangular arrangement.

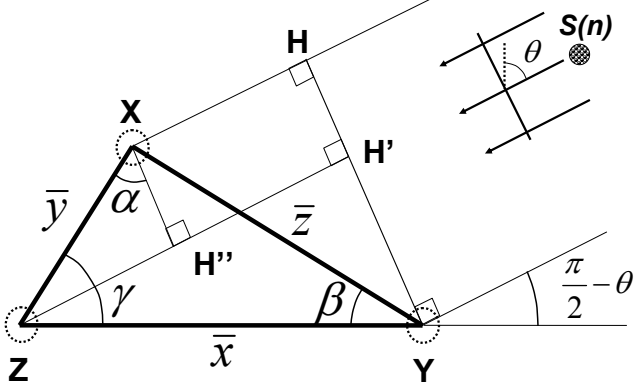

Figure 1: Input signal model in a general triangular microphone array.

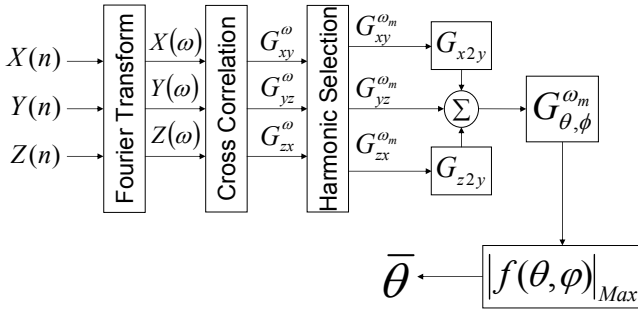

Figure 2: Blockdiagram of the proposed method.

3. PROPOSED DOA ESTIMATION

3.1 Algorithm Development

Let us consider a general triangular microphone array as shown in Fig. 1. Angles of the vertices and lengths of the sides with this triangle are given by

$$\angle ZXY = \alpha, \quad \angle XYZ = \beta, \quad \angle YZX = \gamma, \quad (7)$$

$$\overline{ZY} = \bar{x}, \quad \overline{XZ} = \bar{y}, \quad \overline{XY} = \bar{z}. \quad (8)$$

A speaker in a direction θ utters a speech signal $s(n)$. According to Fig. 1, the following observations can be verified:

$$\angle XYH = \theta - \beta, \quad (9)$$

$$\angle H'ZY = \frac{\pi}{2} - \theta, \quad (10)$$

$$\angle XZH' = \theta + \gamma - \frac{\pi}{2}, \quad (11)$$

and therefore,

$$\overline{XH} = \bar{z} \sin(\theta - \beta), \quad (12)$$

$$\overline{ZH'} = \bar{x} \sin \theta, \quad (13)$$

$$\overline{ZH''} = \bar{y} \cos(\theta + \gamma - \frac{\pi}{2}). \quad (14)$$

According to Fig. 1, the delays between the signals at each pair of microphones are given by

$$\tau_{xy}(\theta) = \bar{z} \sin(\theta - \beta + \pi) / c, \quad (15)$$

$$\tau_{yz}(\theta) = \bar{x} \sin \theta / c, \quad (16)$$

$$\tau_{zx}(\theta) = \bar{y} \sin(\theta + \gamma - \pi) / c, \quad (17)$$

where $\tau_{ab}(\theta)$ represents the relative delay of the signal at microphone B to that at microphone A. Suppose that $\Phi_{ss}(\omega)$ is the power spectral density of $s(n)$. The cross correlation of the two signals at each microphone pair is defined using $\tau_{xy}(\theta)$, $\tau_{yz}(\theta)$ and $\tau_{zx}(\theta)$ as follows.

$$\Phi_{xy}^{(\omega)}(\theta) = \Phi_{ss}(\omega) e^{-j\omega \tau_{xy}(\theta)}, \quad (18)$$

$$\Phi_{yz}^{(\omega)}(\theta) = \Phi_{ss}(\omega) e^{-j\omega \tau_{yz}(\theta)}, \quad (19)$$

$$\Phi_{zx}^{(\omega)}(\theta) = \Phi_{ss}(\omega) e^{-j\omega \tau_{zx}(\theta)}, \quad (20)$$

where $\Phi_{ab}^{(\omega)}(\theta)$ represents the crosscorrelation between the signals at microphones B and A.

Now, let us consider the difference in the delay term between two cross correlations for a signal propagating from a direction ϕ

$$\tau_{x2y}(\phi) \triangleq \tau_{yz}(\phi) - \tau_{xy}(\phi), \quad (21)$$

$$\tau_{z2y}(\phi) \triangleq \tau_{yz}(\phi) - \tau_{zx}(\phi). \quad (22)$$

Then, the following *phase rotation factors* are defined as

$$G_{x2y}^{(w)}(\phi) \triangleq e^{-j\omega \tau_{x2y}(\phi)}, \quad (23)$$

$$G_{z2y}^{(w)}(\phi) \triangleq e^{-j\omega \tau_{z2y}(\phi)}. \quad (24)$$

Using these phase rotation factors, the following *integrated cross spectrum* is defined.

$$G_{\phi, \theta}^{(w)} \triangleq G_{x2y}^{(w)}(\phi) G_{xy}^{(w)}(\theta) + G_{yz}^{(w)}(\theta) + G_{z2y}^{(w)}(\phi) G_{zx}^{(w)}(\theta), \quad (25)$$

where

$$G_X^{(w)}(\theta) = \frac{\Phi_X^{(w)}(\theta)}{|\Phi_X^{(w)}(\theta)|} = e^{-j\omega \tau_X(\theta)} \quad (X = xy, yz \text{ or } zx) \quad (26)$$

Theorem 1. For any triangular microphone array, the integrated cross spectrum satisfies the following inequality

$$|G_{\phi, \theta}^{(w)}| \leq 3. \quad (27)$$

A proof is given in Appendix B.

Theorem 2. For any triangular microphone arrangement, the following equality is satisfied

$$|G_{\phi, \theta}^{(w)}| = 3, \quad (28)$$

if and only if $\theta = \phi$.

For a proof, see Appendix C.

Theorem 2 leads a DOA estimation problem to search for a ϕ that maximizes the amplitude of the integrated cross spectrum function. In addition, the proposed method can discriminate the signal from omni-direction, because the preceding theorem holds for θ between 0 and 2π . Its blockdiagram is shown in Fig. 2.

Corollary 3. In the equilateral triangular microphone array, the amplitude of the integrated cross spectrum reaches its maximum, if and only if $\theta = \phi$.

As Corollary 3 shows, the method by Hioka and Hamada in [12] is a special case of Theorem 2.

Table 1: Parameters for Simulation.

Sound velocity	340 m/s
Sampling Frequency	16000 Hz
Input SNR	20 dB
Frame Size	1024 Samples
Window Function	Hamming
Overlap	50%
\bar{x}	0.010 m
\bar{y}	0.021 m
\bar{z}	0.018 m
α	30°
β	90°
γ	60°

3.2 Noise Robustness

According to (3), the DOA θ is given by

$$\theta = \sin^{-1}\left(\frac{c\tau}{d}\right), \quad (29)$$

which means that any estimation error in τ causes an error in θ . Due to the noise in the real environment, the estimated value of τ generally contains an error. In order to evaluate the sensitivity of DOA estimation with respect to the noise, let us define a noise robustness factor (NRF), $I(\theta)$, as follows.

$$I(\theta) = \left| \frac{d\theta}{d\hat{\tau}} \right|^{-1}, \quad (30)$$

where $\hat{\tau}$ is an estimate of τ . In the case of two-microphone array, the NRF is reduced to [13]

$$I_2(\theta) = |\cos \theta|. \quad (31)$$

On the other hand, in the case of a triangular microphones array, the NRF is an average of the three NRFs for each pair of microphones.

$$I_3(\theta) = \frac{1}{3} (|\cos \theta| + |\cos(\theta - \beta)| + |\cos(\theta + \gamma)|) \quad (32)$$

Please note that \overline{XY} and \overline{XZ} are tilted with respect to \overline{YZ} by $-\beta$ and $+\gamma$, respectively. As is clear from (32), the microphone arrangement has direct effects on the NRF. Naturally, by setting $\beta = \gamma = 60^\circ$, (32) reduces to (34) in [13].

4. EVALUATIONS

4.1 Conditions for Evaluations

In order to evaluate the performance of the proposed DOA estimation method, computer simulations have been performed. The microphones were virtually located at the vertices of a triangle as shown in Fig. 1. Two real speech signals, one of male and the other of female, have been used as the source signal. The input signals to the microphone array were generated by appropriately delaying the source signal according to θ . A white gaussian noise (AWGN) was added to each microphone signal, whereas reverberation was not taken into account. It is important to notice that the maximum distance D_{max} between each pair of microphones is determined by the sampling frequency.

$$D_{max} = \frac{c}{f_s}, \quad (33)$$

where c and f_s are the sound velocity and the sampling frequency. In the case of 16 KHz sampling, D_{max} is approximately 0.021 m. Parameters of simulations are summarized in Table 1.

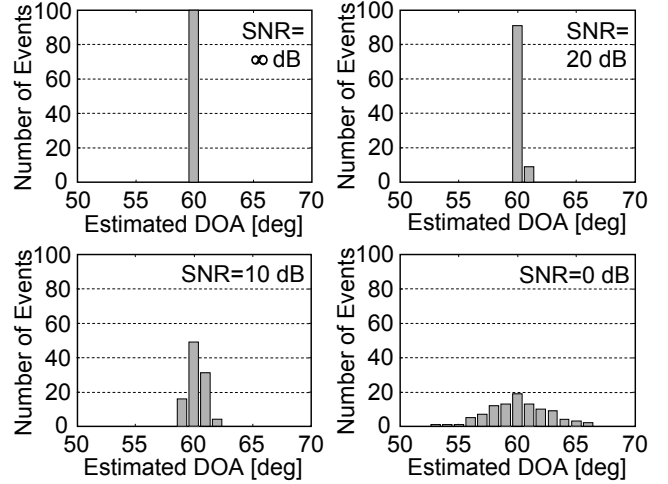

Figure 3: DOA estimation results for different SNRs for $\theta = 60^\circ$.

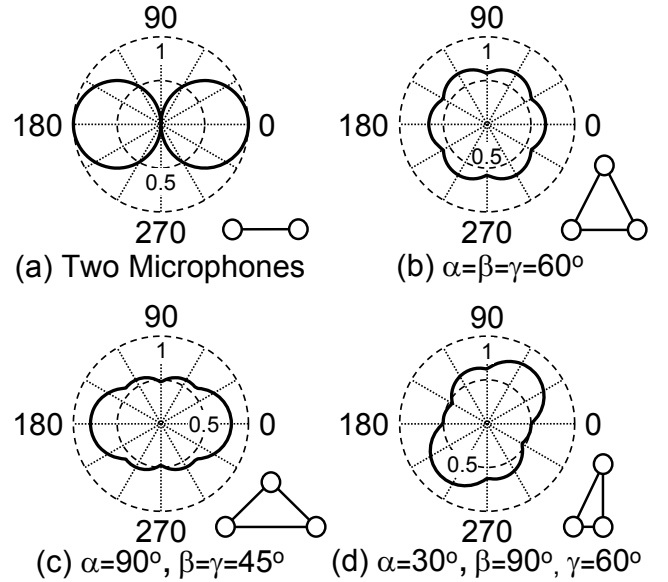

Figure 4: NRF by (31) and (32) for different microphone arrangements.

4.2 DOA Estimation in Noisy Environment

DOA estimation was performed for different SNRs to evaluate robustness against noise. The source was virtually fixed at a DOA of 60 degrees. The results are shown in Fig. 3 for SNRs of ∞ , 20, 10 and 0 dB. As is depicted in Fig. 3, DOA-estimation accuracy decreases for a higher noise level. The variance of the estimated DOA becomes larger for low SNRs.

4.3 Noise Robustness for Different Microphone Arrangements

Figure 4 plots the NRFs in (31) for the two-microphone array and (32) for an equilateral, an isosceles, and a general triangular microphone arrays. In the case of equilateral triangular microphone array, the NRF is close to the omnidirectional pattern. It is also seen that the NRF is compressed in the direction perpendicular to the longest sides.

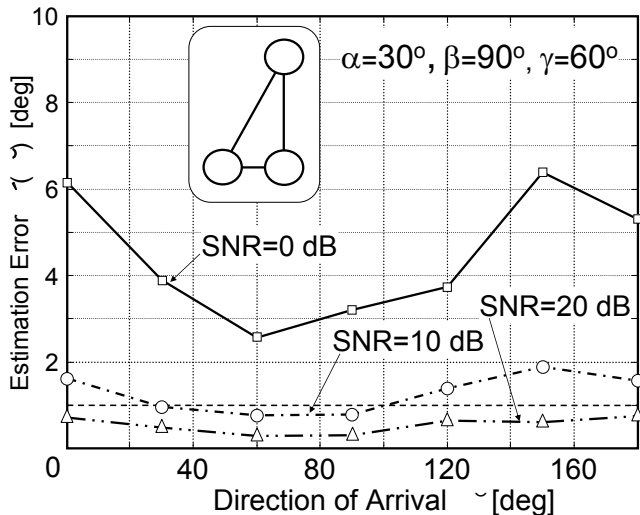

Figure 5: Estimation error for different SNRs.

4.4 Error in DOA Estimation

Errors in DOA estimation were evaluated by an estimation error, $\delta(\theta)$, which is defined by

$$\delta(\theta) = \sqrt{\frac{1}{K} \sum_{i=1}^K |\hat{\theta}_i - \theta|^2}. \quad (34)$$

$\hat{\theta}_i$ and θ are the estimated DOA at the i -th iteration and the true DOA. $\delta(\theta)$ for three SNRs, namely, 20, 10, and 0 dB, with K set to 100 are shown in Fig. 5. The microphone arrangement was assumed to be a general triangle as in Tab. 1. As the SNR becomes higher, the error $\delta(\theta)$ becomes smaller. It is demonstrated that $\delta(\theta)$ for an SNR of 20 dB is smaller than 1 degree which is comparable to high resolution DOA methods like MUSIC [8].

Fig. 6 depicts the error, $\delta(\theta)$, for $0 \leq \theta < 360$ with a step of 5 degrees for three different triangular microphone arrangements. These arrangements were selected for comparison with Fig. 4 (b) – (d). Comparing Fig. 6 with Fig. 4 (b) – (d), the estimation error is larger when the NRF is small. This fact is intuitively natural because the NRF is an index to the robustness to the relative delay that determines the DOA.

5. CONCLUSION

A new DOA (direction of arrival) estimation method for an arbitrary triangular microphone arrangement has been proposed. A general form of the integrated cross spectrum has been derived using the phase rotation factors. It has been shown that a DOA is estimated by solving a non-linear optimization problem of the general integrated cross spectrum. A closed-form solution to the sensitivity to the relative time-delay has been derived and demonstrated for different microphone arrangements. Simulation results have demonstrated that the deviation of estimation error in the case of 20 dB SNR is less than 1 degree, which is comparable to high resolution DOA estimation methods.

REFERENCES

[1] M. Brandstein and H. Silverman, "A practical methodology for speech localization with microphone arrays," Technical Report, Brown University, Nov. 1996.
 [2] S. Birchfield and D. Gillmor, "Acoustic source direction by hemisphere sampling," Proc. of ICASSP2001, pp.3053-3056, May 2001.

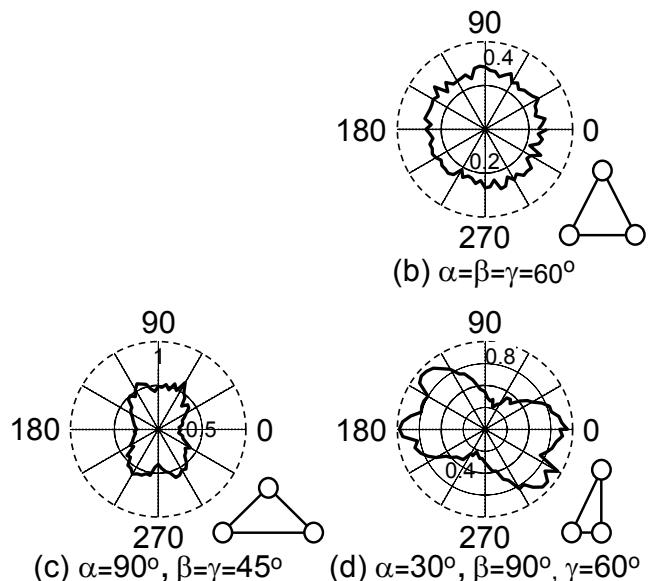

Figure 6: Error $\delta(\theta)$ in (34) for different microphone arrangements.

[3] H. Wang and P. Chu, "Voice source localization for automatic camera pointing system in videoconferencing," Proc. of ICASSP97, pp.187-190, Apr. 1997.
 [4] M. S. Brandstein and S. M. Griebel, "Nonlinear, model-based microphone array speech enhancement," Acoustic Signal Processing for Telecommunications, ed. S. L. Gay and J. Benesty, Kluwer Academic Publishers, 2000.
 [5] D. Li and S. Levinson, "Adaptive sound source localization by two microphones," Proc. of ICASSP2001, p.143, May 2001.
 [6] B. V. Veen and K. M. Buckley, "Beamforming Techniques for Spatial Filtering," CRC Digital Signal Processing Handbook, 1999.
 [7] J. H. DiBiase, H. F. Silverman, and M. S. Brandstein, "Microphone Arrays, Signal Processing Techniques and Applications," Springer Verlag, 2001.
 [8] R. O. Schmidt, "Multiple emitter location and signal parameter estimation," IEEE Trans. on Antennas and Propagation, vol. AP-34, no. 3, pp.276-280, Mar. 1986.
 [9] R. Roy and T. Kailath, "ESPRIT: estimation of signal parameters via rotational invariance techniques," IEEE Trans. on ASSP, vol. 37, no. 7, pp.984-95, Jul. 1989.
 [10] C. Knapp, G. Carter, "The generalized correlation method for estimation of time delay," IEEE Trans. ASSP, Vol.24, pp.320-327, Aug. 1976.
 [11] M. Sato, A. Sugiyama, O. Houshuyama N. Yamashita, and Y. Fujita, "Near-field sound-source localization based on a signed binary code," IEICE Trans. Fundamentals, vol. E88, No. 8, Aug. 2005.
 [12] Y. Hioka and N. Hamada, "A tracking algorithm of speaker direction using microphones located at vertices of equilateral-triangle," Proc. of EUSIPCO2004, pp.1983-1986, Sep. 2004.
 [13] Y. Hioka and N. Hamada, "DOA estimation of speech signal using microphones located at vertices of equilateral triangle," IEICE Trans. Fundamentals, vol.E87-A, no.3, pp.559-556, Mar. 2004.
 [14] Y. Rui, D. Florêncio, W. Lam, and J. Su, "Sound source localization for circular array of directional microphones," Proc. of ICASSP2005
 [15] S. G. Krantz, "Handbook of Complex Variables. Boston, MA: Birkhäuser, p.12, 1999.
 [16] M. Abramowitz and I. A. Stegun, (Eds.), "Handbook of Mathematical Functions with Formulas, Graphs, and Mathematical Tables," 9th Printing, New York: Dover, p.79, 1972.

Appendix A. PRELIMINARIES

Lemma 4. [15]

For complex numbers a_1, a_2, \dots, a_n , the following inequality holds.

$$|a_1 + a_2 + \dots + a_n| \leq |a_1| + |a_2| + \dots + |a_n|, \quad (\text{A.1})$$

The equality is satisfied if and only if

$$\arg(a_1) = \arg(a_2) = \dots = \arg(a_n). \quad (\text{A.2})$$

Lemma 5. [16]

For any triangle $\triangle XYZ$ with the circumradius R , the following equalities hold.

$$\frac{\sin(\alpha)}{\bar{x}} = \frac{\sin(\beta)}{\bar{y}} = \frac{\sin(\gamma)}{\bar{z}} = 2R. \quad (\text{A.3})$$

Appendix B. PROOF OF THEOREM 1

Proof. Substituting (23), (24) and (26) into (25) yields

$$G_{\phi, \theta}^{(w)} = e^{-j\omega\tau_{x2y}(\phi)} e^{-j\omega\tau_{xy}(\theta)} + e^{-j\omega\tau_{yz}(\theta)} + e^{-j\omega\tau_{z2y}(\phi)} e^{-j\omega\tau_{zx}(\theta)}. \quad (\text{A.4})$$

Using Lemma 4,

$$\begin{aligned} |G_{\phi, \theta}^{(w)}| &\leq |e^{-j\omega\tau_{x2y}(\phi)} e^{-j\omega\tau_{xy}(\theta)}| + \\ &\quad |e^{-j\omega\tau_{yz}(\theta)}| + |e^{-j\omega\tau_{z2y}(\phi)} e^{-j\omega\tau_{zx}(\theta)}| \\ &= 3. \end{aligned} \quad (\text{A.5})$$

□

Appendix C. PROOF OF THEOREM 2

Proof. For proving sufficiency, let us assume that $\theta = \phi$ and investigate the argument of each term in (A.4). Then,

$$\begin{aligned} \arg\left(e^{-j\omega\tau_{x2y}(\phi)} e^{-j\omega\tau_{xy}(\theta)}\right) &= \arg\left(e^{-j\omega\tau_{yz}(\theta)}\right) \\ &= \arg\left(e^{-j\omega\tau_{z2y}(\phi)} e^{-j\omega\tau_{zx}(\theta)}\right) \\ &= \omega \frac{\bar{x} \sin \theta}{c}. \end{aligned} \quad (\text{A.6})$$

Using Lemma 4, (A.6), and (A.5), it is clear that the equality is satisfied.

For proving necessity, let us consider Lemma 4. The following equalities are obtained for the first two terms of $G_{\phi, \theta}^{(w)}$.

$$\arg\left(e^{-j\omega\tau_{x2y}(\phi)} e^{-j\omega\tau_{xy}(\theta)}\right) = \arg\left(e^{-j\omega\tau_{yz}(\theta)}\right). \quad (\text{A.7})$$

(A.7) and (21) result in

$$\tau_{xy}(\theta) - \tau_{xy}(\phi) = \tau_{yz}(\theta) - \tau_{yz}(\phi). \quad (\text{A.8})$$

Substituting (15) and (16) into (A.8) yields

$$\bar{z}(\sin(\theta - \beta + \pi) - \sin(\phi - \beta + \pi)) = \bar{x}(\sin \theta - \sin \phi), \quad (\text{A.9})$$

or equivalently,

$$\begin{aligned} \bar{z} \sin\left(\frac{\theta - \phi}{2}\right) \cos\left(\frac{\theta + \phi}{2} - \beta + \pi\right) \\ = \bar{x} \sin\left(\frac{\theta - \phi}{2}\right) \cos\left(\frac{\theta + \phi}{2}\right). \end{aligned} \quad (\text{A.10})$$

If $\sin\left(\frac{\theta - \phi}{2}\right) = 0$, then, the following relation between θ and ϕ is obtained.

$$\phi = \theta, \quad \text{or} \quad \phi = \theta + 2\pi. \quad (\text{A.11})$$

Since there is no difference between θ and $\theta + 2\pi$ in DOA estimation, the last equality yields to the aim.

Now, let us assume that $\sin\left(\frac{\theta - \phi}{2}\right) \neq 0$ or equivalently, $\theta \neq \phi$. Then,

$$\begin{aligned} \frac{\bar{x}}{\bar{z}} &= \frac{\cos\left(\frac{\theta + \phi}{2} - \beta + \pi\right)}{\cos\left(\frac{\theta + \phi}{2}\right)} \\ &= \frac{\cos\left(\frac{\theta + \phi}{2}\right) \cos(-\beta + \pi) - \sin\left(\frac{\theta + \phi}{2}\right) \sin(-\beta + \pi)}{\cos\left(\frac{\theta + \phi}{2}\right)} \\ &= \cos(-\beta + \pi) - \tan\left(\frac{\theta + \phi}{2}\right) \sin(-\beta + \pi), \end{aligned} \quad (\text{A.12})$$

that reduces to

$$\begin{aligned} \tan\left(\frac{\theta + \phi}{2}\right) &= \cot(-\beta + \pi) - \frac{\bar{x}}{\bar{z} \sin(-\beta + \pi)} \\ &= -\cot(\beta) - \frac{\bar{x}}{\bar{z} \sin(\beta)}. \end{aligned} \quad (\text{A.13})$$

Again, using Lemma 4, the following equality is obtained for the last two terms of $G_{\phi, \theta}^{(w)}$.

$$\begin{aligned} \tan\left(\frac{\theta + \phi}{2}\right) &= \cot(\gamma - \pi) - \frac{\bar{x}}{\bar{y} \sin(\gamma - \pi)} \\ &= \cot(\gamma) + \frac{\bar{x}}{\bar{y} \sin(\gamma)}. \end{aligned} \quad (\text{A.14})$$

The lefthand sides of (A.13) and (A.14) are equal, thus, the righthand sides should be equal as well.

$$-\cot(\beta) - \frac{\bar{x}}{\bar{z} \sin(\beta)} = \cot(\gamma) + \frac{\bar{x}}{\bar{y} \sin(\gamma)} \quad (\text{A.15})$$

or

$$\begin{aligned} \frac{\bar{x}}{\bar{z} \sin(\beta)} + \frac{\bar{x}}{\bar{y} \sin(\gamma)} &= -\cot(\beta) - \cot(\gamma) \\ &= -\frac{\sin(\beta + \gamma)}{\sin(\beta) \sin(\gamma)} \\ &= -\frac{\sin(\alpha)}{\sin(\beta) \sin(\gamma)}. \end{aligned} \quad (\text{A.16})$$

Using Lemma 5,

$$\frac{\bar{x}}{\bar{z}} = \frac{\sin(\alpha)}{\sin(\gamma)}, \quad \frac{\bar{x}}{\bar{y}} = \frac{\sin(\alpha)}{\sin(\beta)}. \quad (\text{A.17})$$

Therefore,

$$\frac{\sin(\alpha)}{\sin(\gamma) \sin(\beta)} + \frac{\sin(\alpha)}{\sin(\beta) \sin(\gamma)} = -\frac{\sin(\alpha)}{\sin(\beta) \sin(\gamma)} \quad (\text{A.18})$$

that reduces to

$$\frac{3 \cdot \sin(\alpha)}{\sin(\gamma) \sin(\beta)} = 0. \quad (\text{A.19})$$

(A.19) holds only when $\alpha = 0$ or π . It is obvious that α does not take either of these values to form a triangle. Thus, the assumption that ϕ differs from θ is invalid. □